

Soilwoks_標準教學系列

考量地下水位變化之臨時結構開挖設計

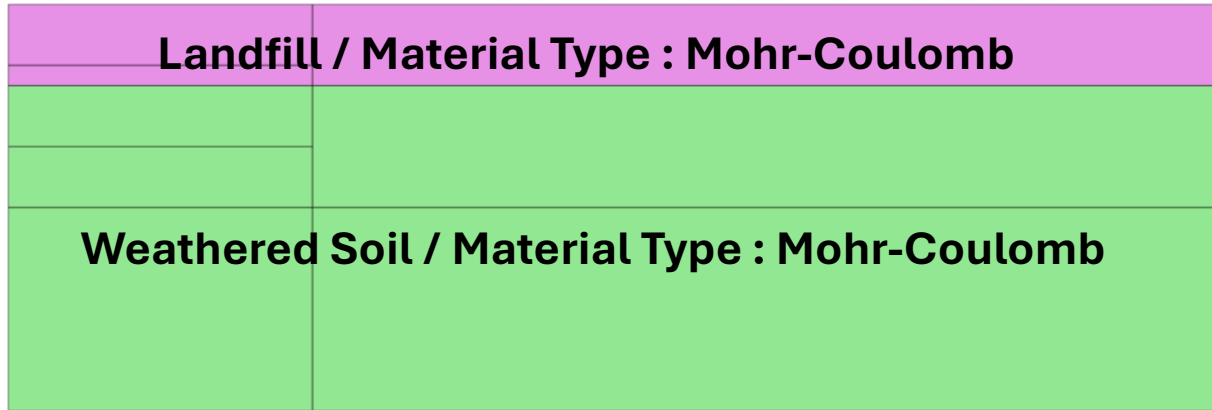

分析說明-材料模型



連續壁&支撐 / Material Type : Steel

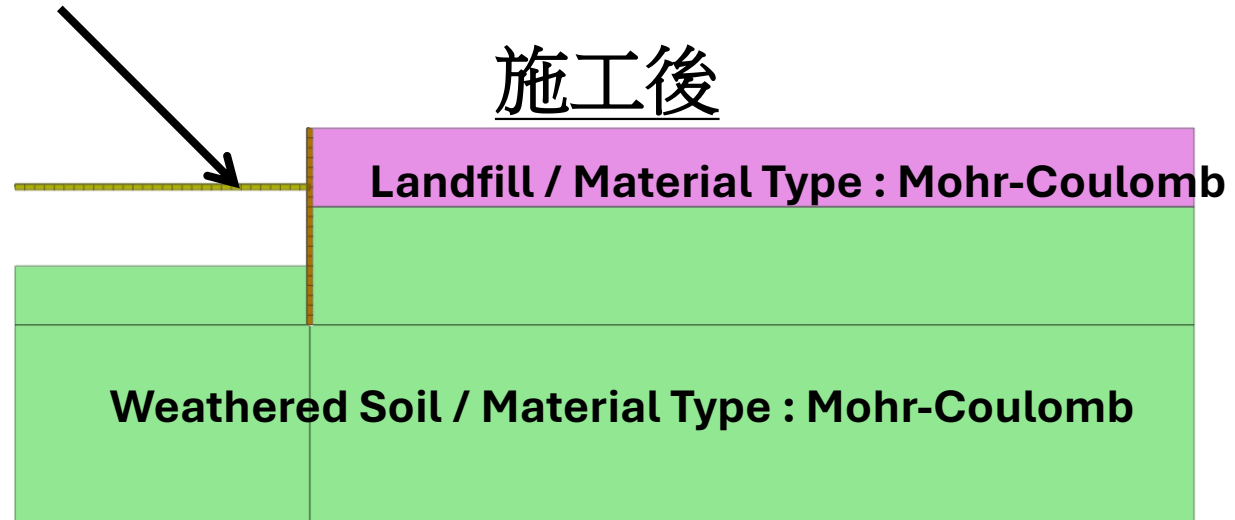

註:範例相關參數使用假設條件。

開挖計算

(不考慮支撐)



開挖計算分析說明-施工流程

(不考慮支撐)

Stage0. Initial

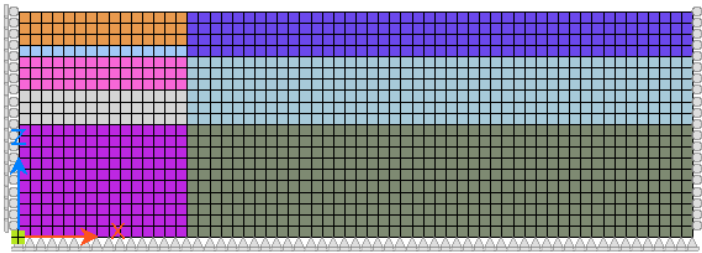

Stage1. Diaphragm Wall

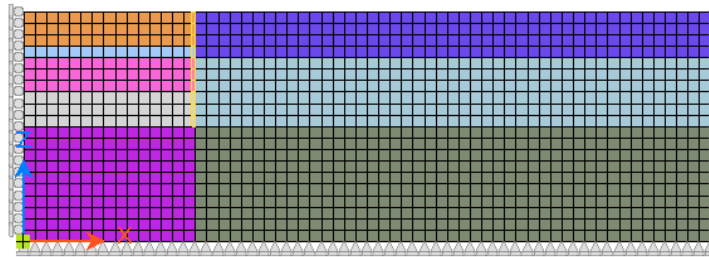

Stage2. Pressure Load

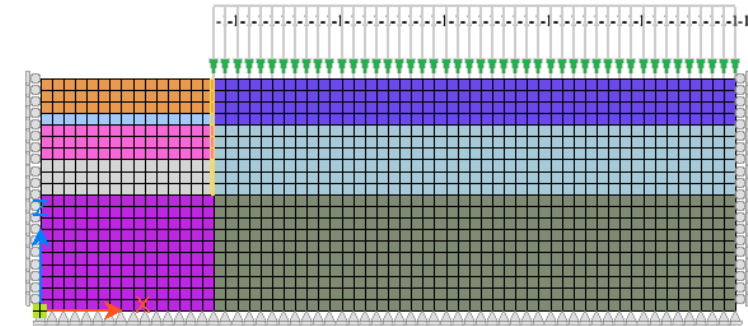

Stage3. 1st Excavation

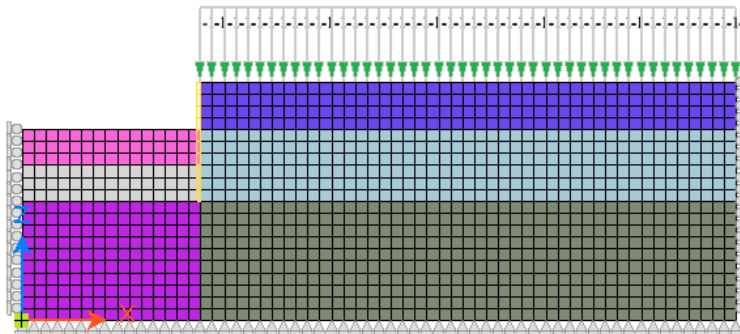

Stage4. 2nd Excavation

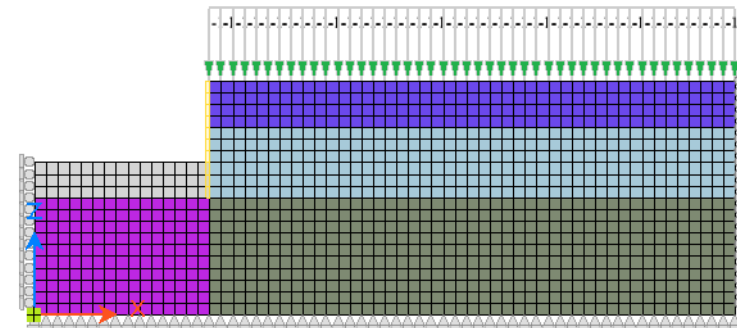

單位切換

The screenshot displays the MIDAS Gen software interface. The main window shows a dark background with a light blue text box that reads "使用者自訂使用單位" (User Customized Unit). Below this, a "Unit Settings" dialog box is open, showing the following settings:

Force Unit [F]	Length Unit [L]	Time Unit [T]
<input type="radio"/> SI	<input checked="" type="radio"/> m	<input checked="" type="radio"/> sec
<input type="radio"/> CGS	<input type="radio"/> cm	<input type="radio"/> min
<input checked="" type="radio"/> tonf	<input type="radio"/> mm	<input type="radio"/> hour
<input type="radio"/> N	<input type="radio"/> ft	<input type="radio"/> day
<input type="radio"/> kN	<input type="radio"/> inch	
<input type="radio"/> lbf		
<input type="radio"/> kips		

Below the dialog box, another light blue text box reads "單位使用tonf/m/sec" (Unit Use tonf/m/sec). The software interface also shows a "Unit Settings" dialog box with the following settings:

Force	tonf	Length	m	Time	sec
<input type="radio"/> SI	<input type="radio"/> CGS	<input type="radio"/> FPS	<input checked="" type="radio"/> User Defined ...		

The "Initial Parameters" section of the dialog box shows the following values:

Gravitational Acceleration	9.807	m/sec ²
Unit Weight of Water	1.000	tonf/m ³
Initial Temperature	0.000	[T]

The software interface also shows a "Message" window at the bottom with a "Command" field and a "Ready" status bar.



語言切換(補充)

Tools工具選單

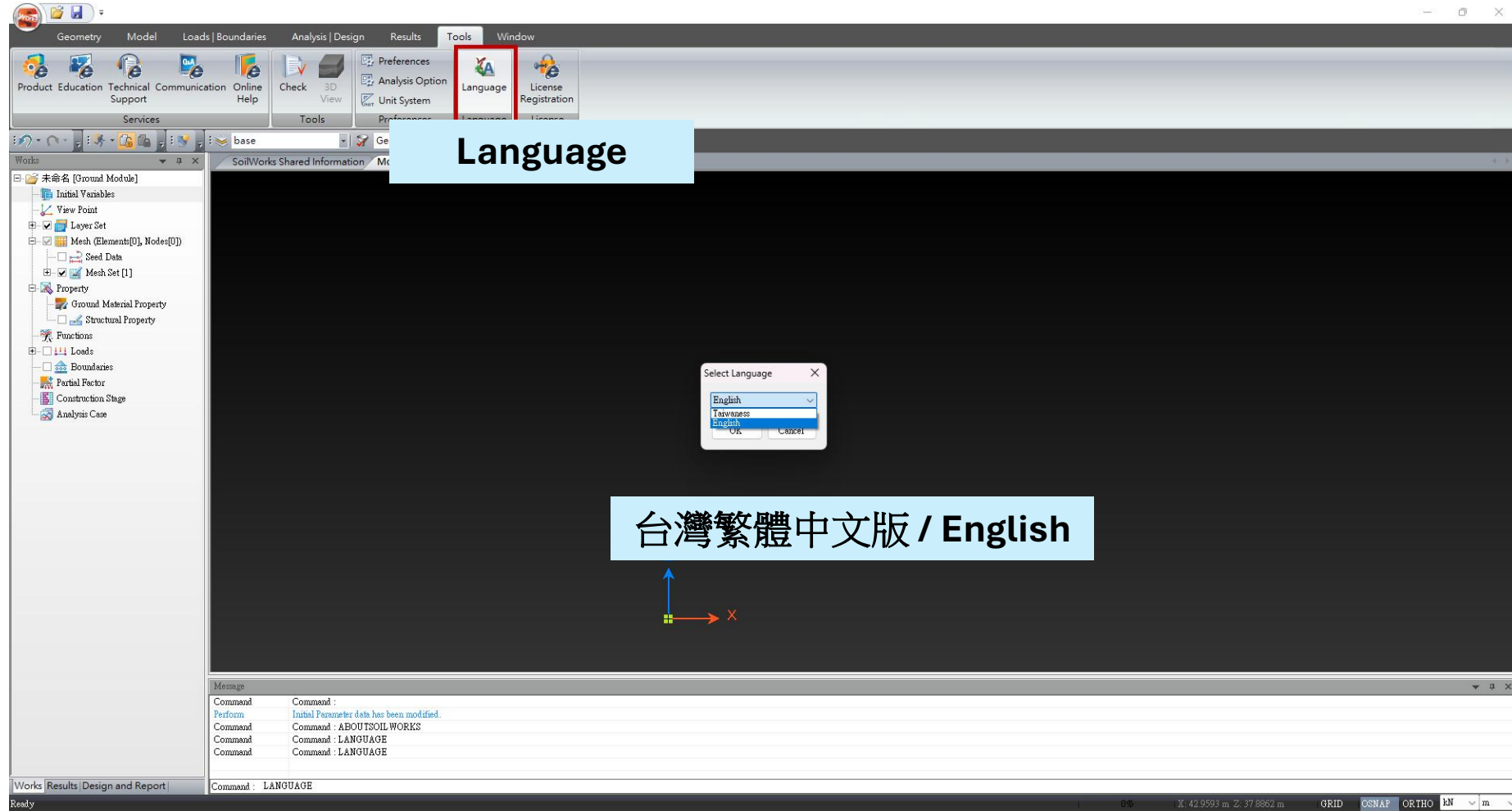

DWG模型匯入

Import>CAD File

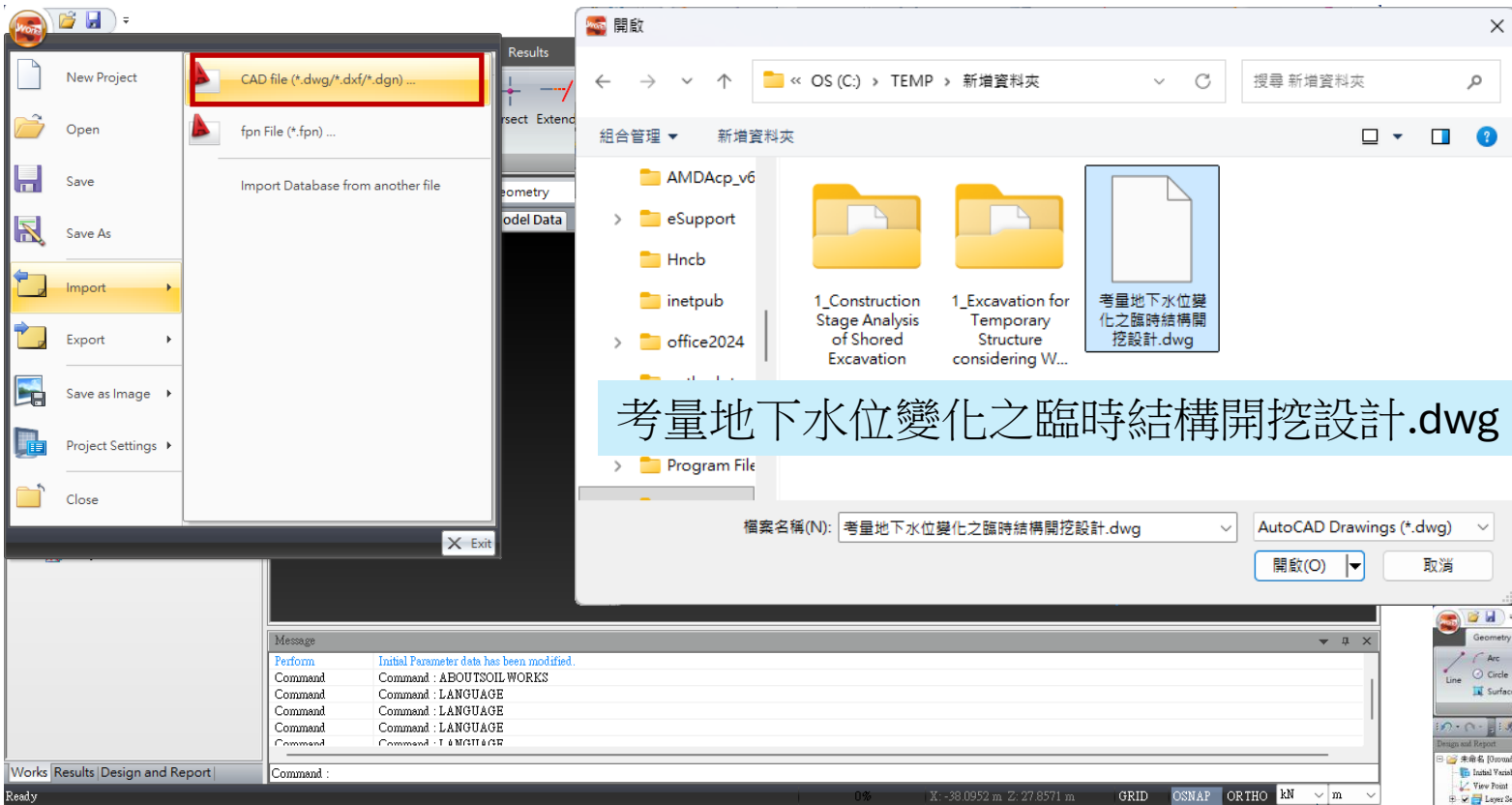

匯入後線特徵模型

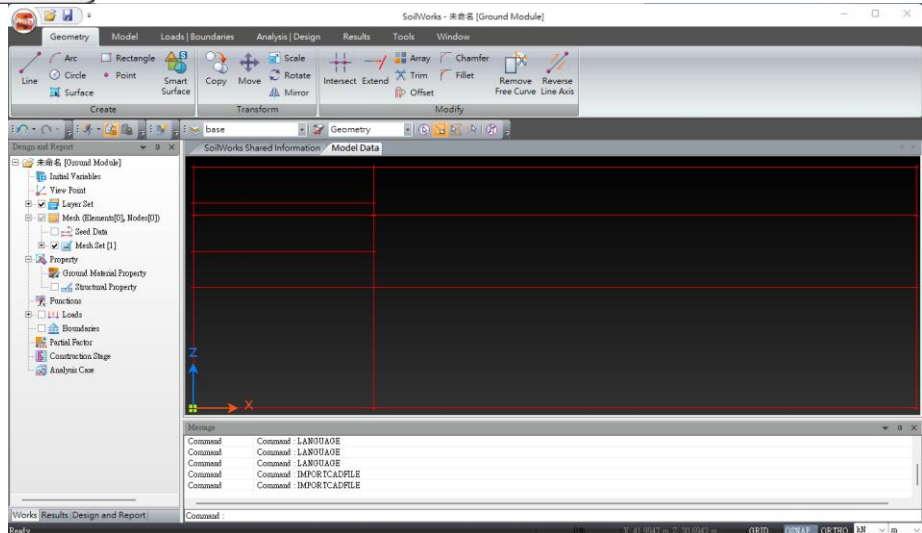
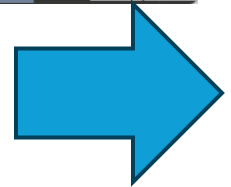

背景白色切換(補充)

Window選單>Display

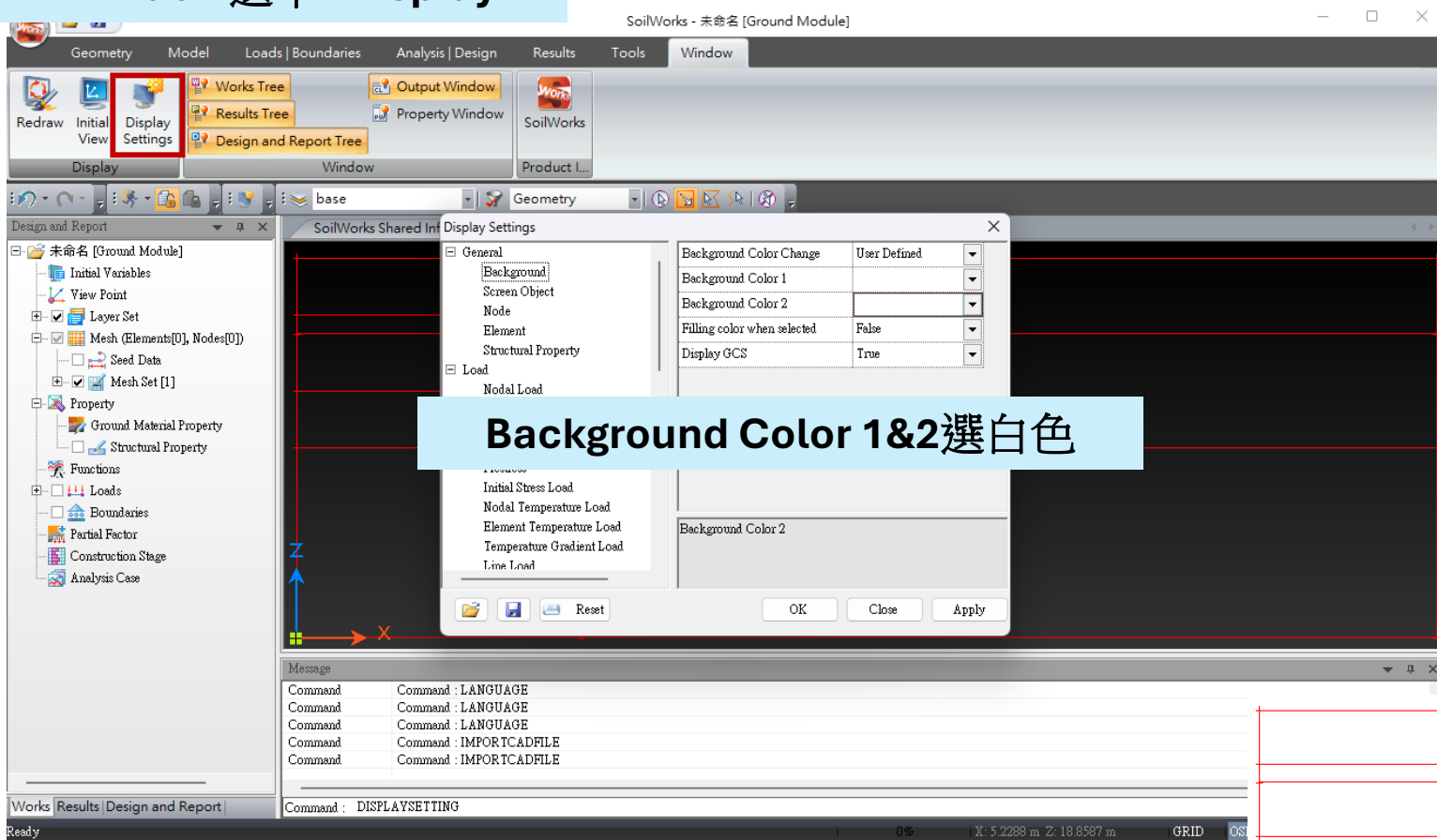

匯入後線特徵模型

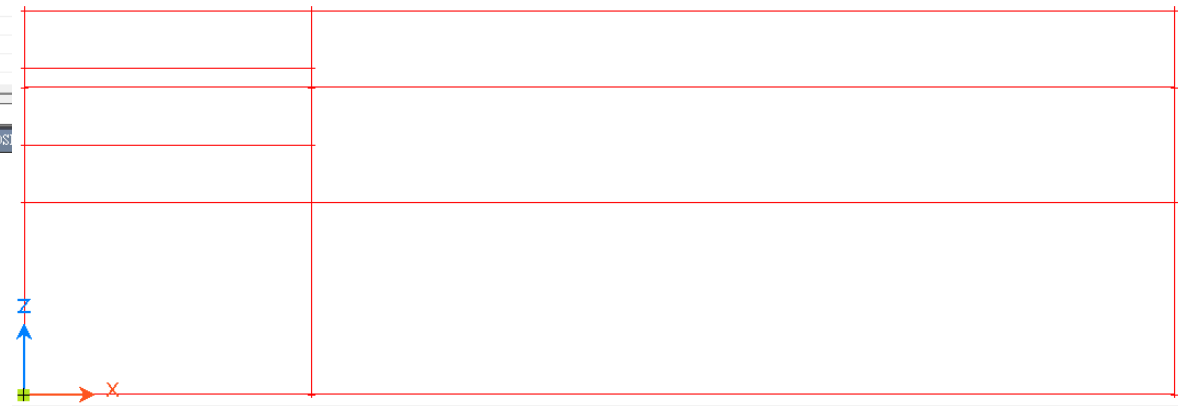
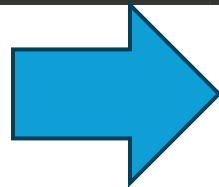

土壤材料屬性

Model選單>Property

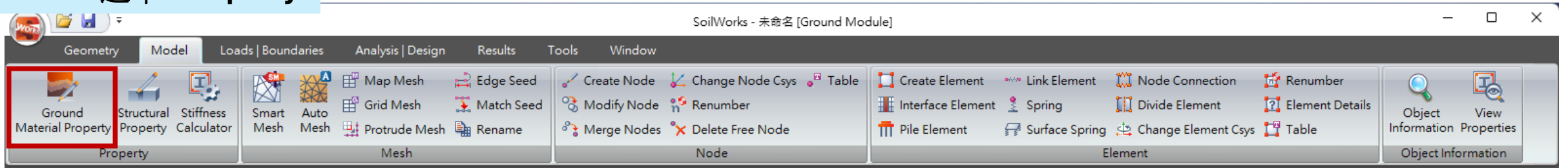

Define Ground Material Property

Name: Landfill
Model Type: Mohr-Coulomb

General Parameters	
Modulus of Elasticity (E)	2000 tonf/m ²
Poisson's Ratio (ν)	0.33
Temperature Coeff. (α)	1E-06
Unit Weight (γt)	1.7 tonf/m ³
Saturated Unit Weight	1.8 tonf/m ³
Cohesion (c)	0 tonf/m ²
Internal Friction Angle (Φ)	30 [deg]
Earth Pressure Coeff. (K0)	0.5
Draining Condition	Drained

Additional Parameters	
Variation in Modulus of Elasticity	0 tonf/m ²
Variation in Cohesion	0 tonf/m ²
Reference Height	0 m
<input type="checkbox"/> Dilatancy Angle (Ψ)	30 [deg]
<input type="checkbox"/> Tensile Strength	203.943 tonf/m ²
<input type="checkbox"/> Calculate Safety Factor (Mohr-Coulomb)	
Cohesion (c)	3.059 tonf/m ²
Internal Friction Angle (φ)	36 [deg]

依照下表參數輸入

Define Ground Material Property

Name: Weathered Soil
Model Type: Mohr-Coulomb

General Parameters	
Modulus of Elasticity (E)	5000 tonf/m ²
Poisson's Ratio (ν)	0.32
Temperature Coeff. (α)	1E-06
Unit Weight (γt)	1.8 tonf/m ³
Saturated Unit Weight	1.9 tonf/m ³
Cohesion (c)	1.5 tonf/m ²
Internal Friction Angle (Φ)	32 [deg]
Earth Pressure Coeff. (K0)	0.47
Draining Condition	Drained

Additional Parameters	
Variation in Modulus of Elasticity	0 tonf/m ²
Variation in Cohesion	0 tonf/m ²
Reference Height	0 m
<input type="checkbox"/> Dilatancy Angle (Ψ)	32 [deg]
<input type="checkbox"/> Tensile Strength	203.943 tonf/m ²
<input type="checkbox"/> Calculate Safety Factor (Mohr-Coulomb)	
Cohesion (c)	3.059 tonf/m ²
Internal Friction Angle (φ)	36 [deg]

	Modulus of Elasticity(E) (tonf/m ²)	Poisson's Ratio(ν)	Unit Weight(γ) (tonf/m ³)	Unit Weight(Saturated) (tonf/m ³)	Cohesion(C) (tonf/m ²)	Friction Angle(φ)	K0
Landfill	2000	0.4	1.7	1.8	0	30	0.5
Weathered Soil	5000	0.35	1.8	1.9	1.5	32	0.47



結構屬性-Diaphragm Wall

Model選單>Property

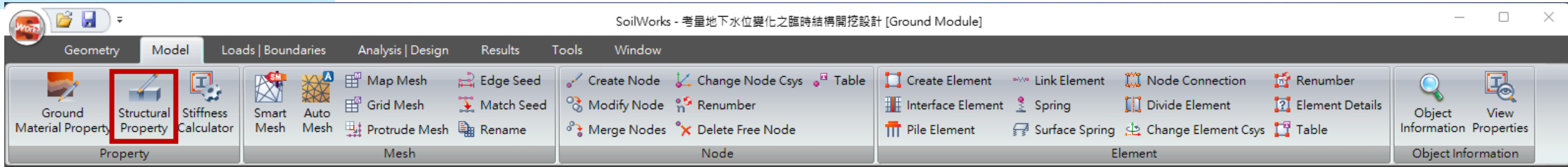

依照Section Table輸入選取

依照Section Table輸入

依照Material Table輸入

Define Structural Property

Data

ID	Name
1	Diaphragm Wall

General

ID 1 Name Diaphragm Wall

Element Type Beam

Standard NONE

Horizontal Spacing 1.8 m

Section

Shape H Tapered Section

Sub-Shapes U Type

Section User Defined

Section-2 User Defined

Material

Material Type Steel

材料類型選Steel

Section Data Material Data

Section Section-2 Stiffness

Section	
H	0.3 m
B1	0.3 m
tw	0.015 m
tf1	0.015 m
B2	0 m
tf2	0 m
Stiffness Calculation	
Area	0.01305 m ²
Iy	0.000208 m ⁴
Zy	0.001384 m ³
Ry	0.126105 m

Section Data Material Data

User Defined Steel

Properties	
Modulus of Elasticity	21000000 tonf/m ²
Poisson's Ratio	0.3
Unit Weight	8 tonf/m ³
Thermal Coefficient	0.000012
Design Strength	
Yield Strength	40000 tonf/m ²

	Element Type	Horizontal Spacing (m)	Section
Diaphragm Wall	Beam	1.8	H (0.3x0.3x0.015/0.015)

Material Type	Modulus of Elasticity(E)(tonf/m ²)	Poisson's Ratio(v)	Unit Weight(γ)(tonf/m ³)	Yield Strength(tonf/m ²)
Steel	21,000,000	0.3	8	40,000



結構屬性-Strut

Model選單>Property

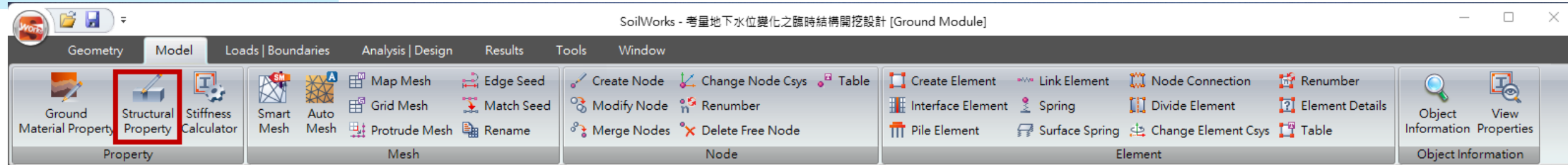

依照Section Table輸入選取

依照Section Table輸入

依照Material Table輸入

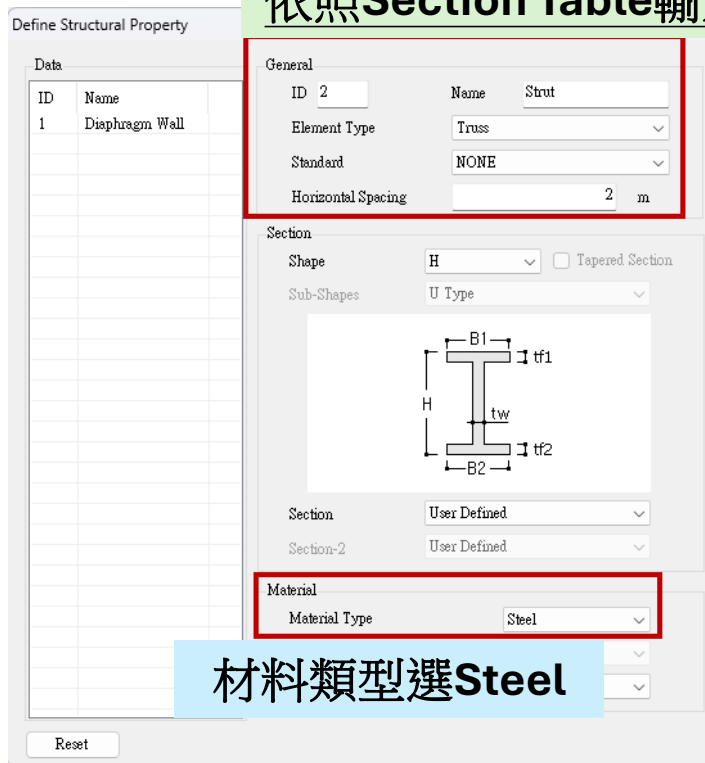

材料類型選Steel

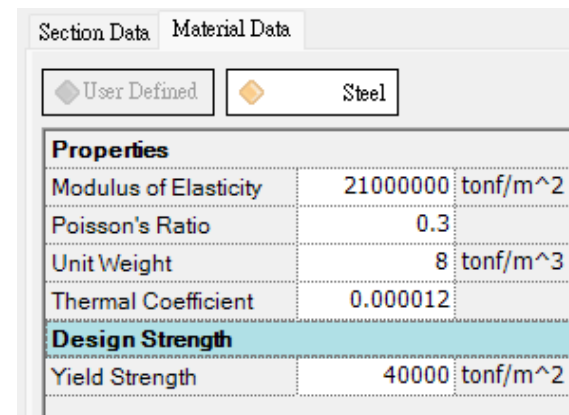
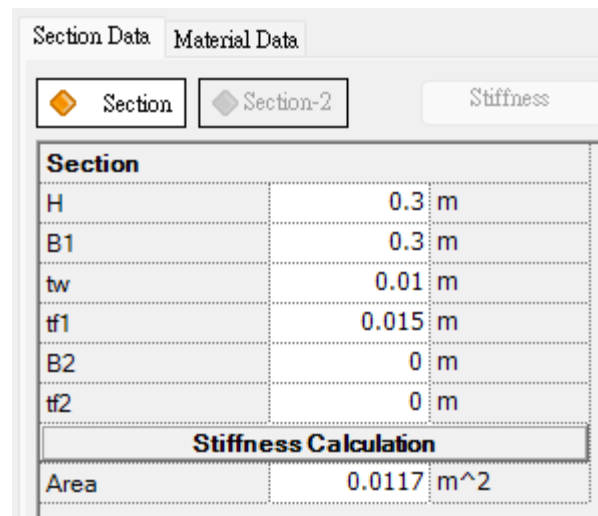

Strut	Element Type	Horizontal Spacing (m)	Section
	Truss	2	H (0.3×0.3×0.01/0.015)

Material Type	Modulus of Elasticity(E)(tonf/m ²)	Poisson's Ratio(v)	Unit Weight(γ)(tonf/m ³)	Yield Strength(tonf/m ²)
Steel	21,000,000	0.3	8	40,000



面特徵建立

Geometry 選單>Smart Surface

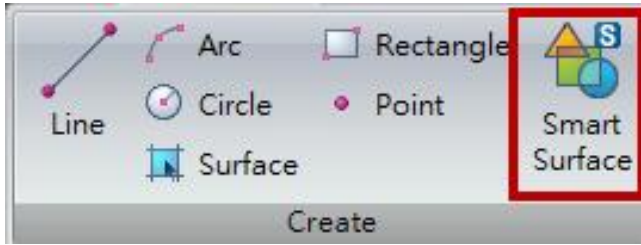

自動生成面特徵

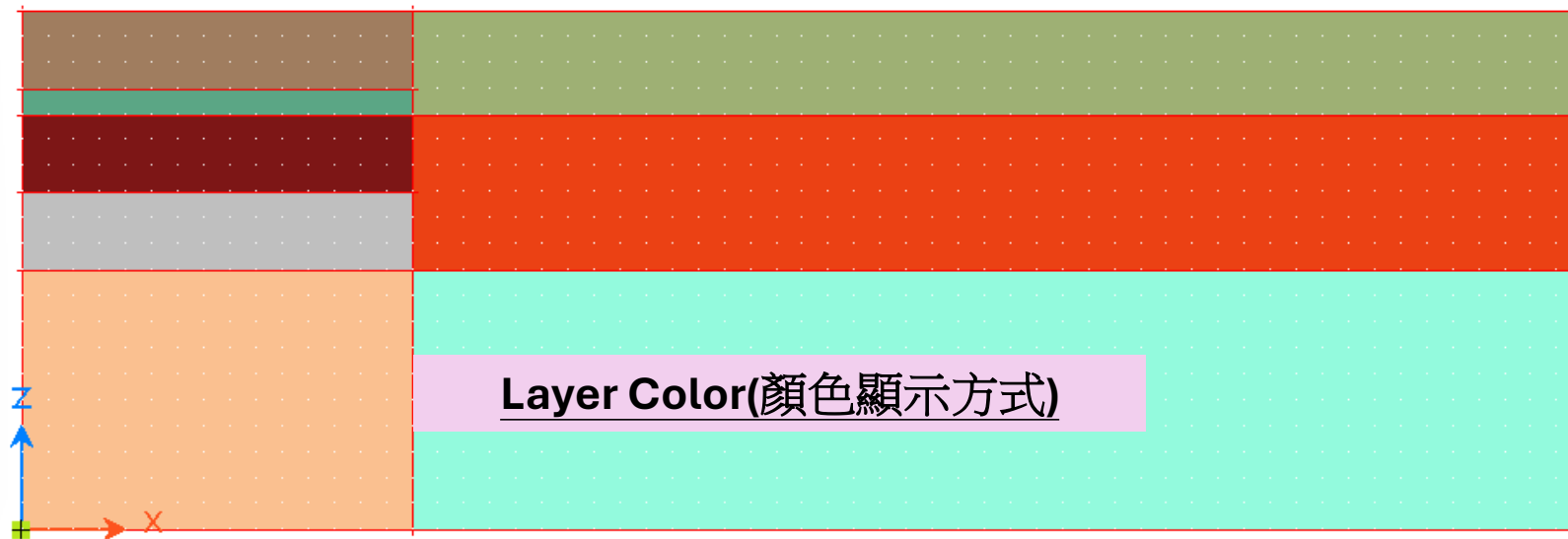

土壤材料屬性指定

Select Filter 切換到 Surface

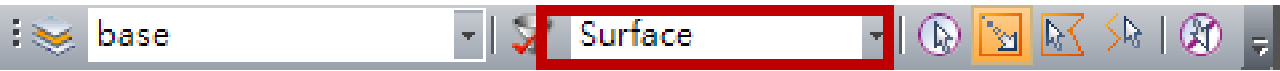

框選 Landfill 土壤分布區域特徵

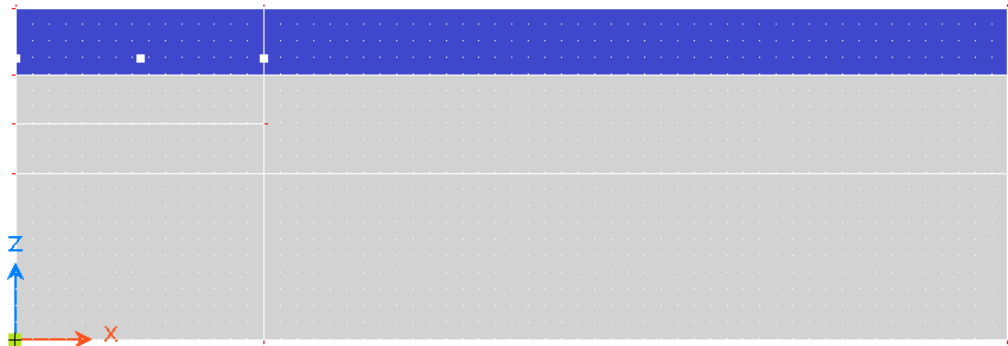

框選 Weathered Soil 土壤分布區域特徵

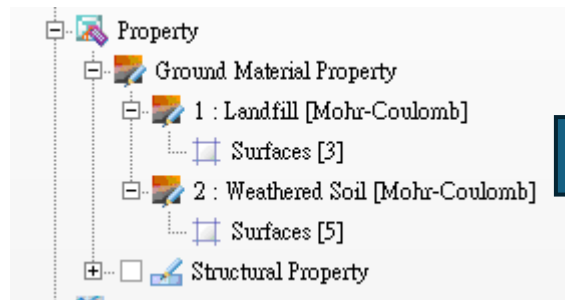
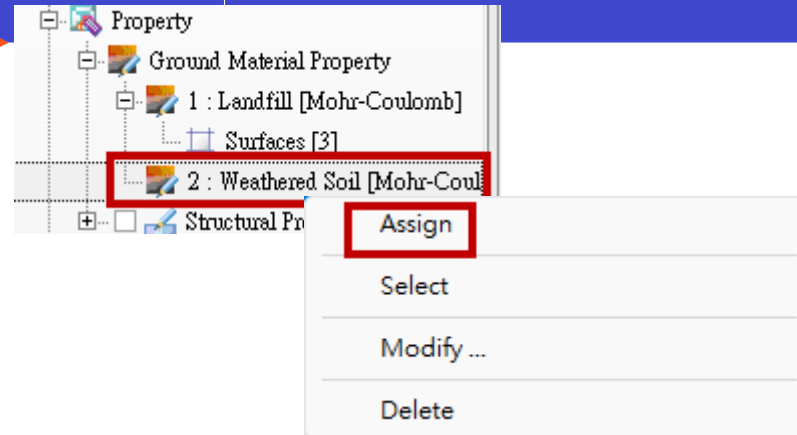
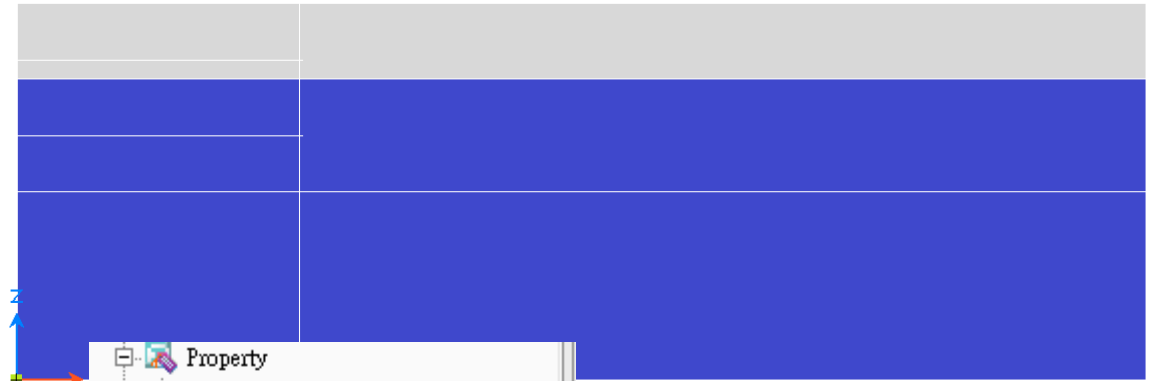

Ground Material Property 模型樹顯示指定特徵數量



顏色顯示(補充)

自訂屬性顏色

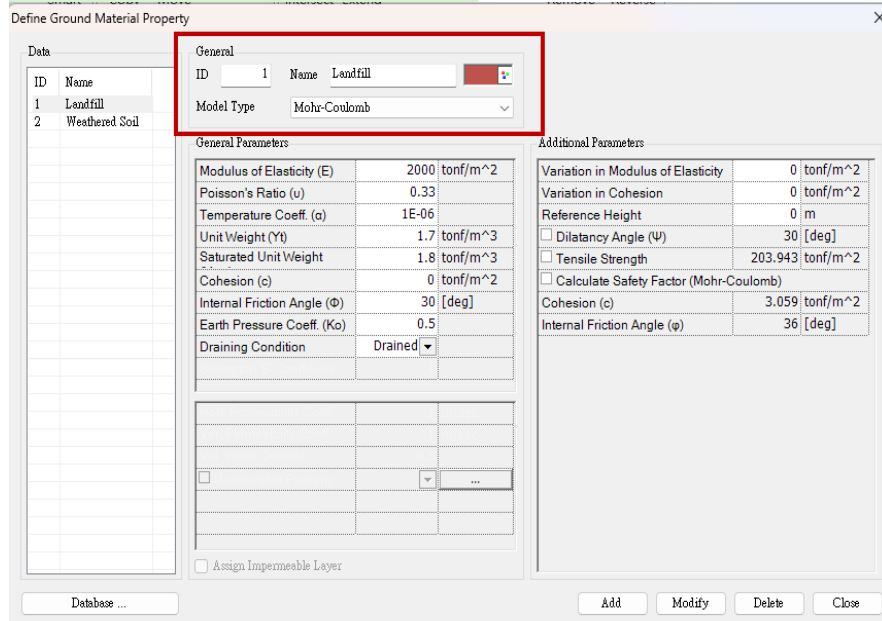

Display Setting顯示設定

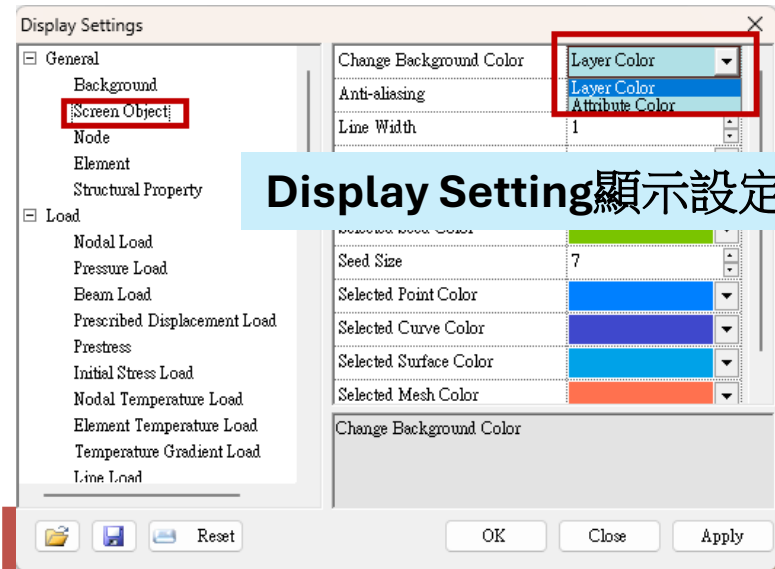

Display Setting顯示設定

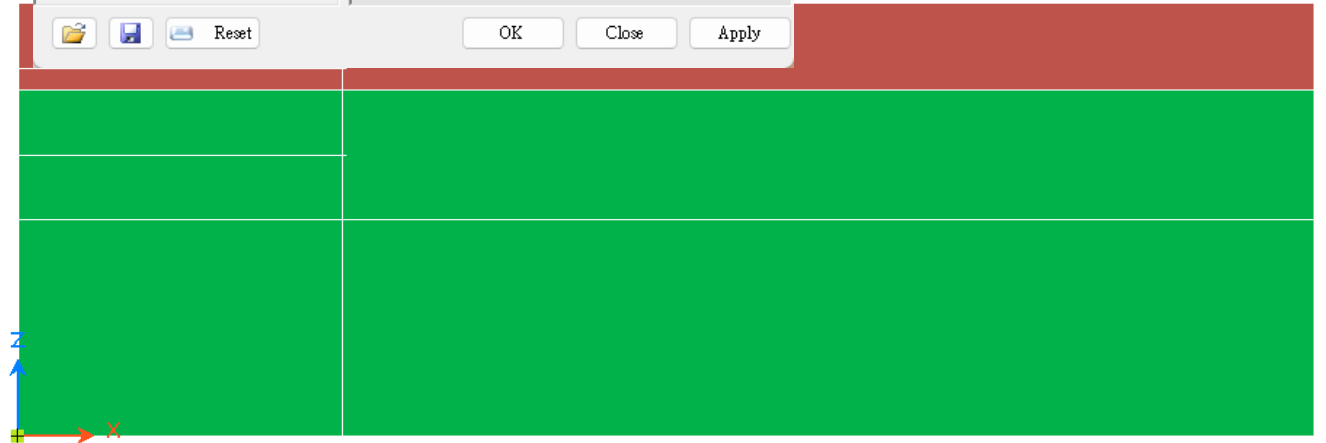

Attribute Color (顏色顯示方式)
(Property Color)

結構屬性指定

Select Filter 切換到 Curve

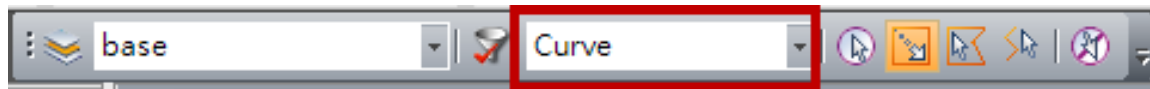

Diaphragm Wall

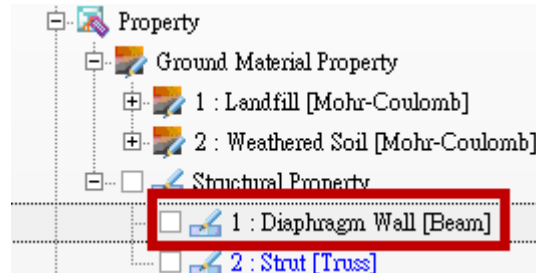
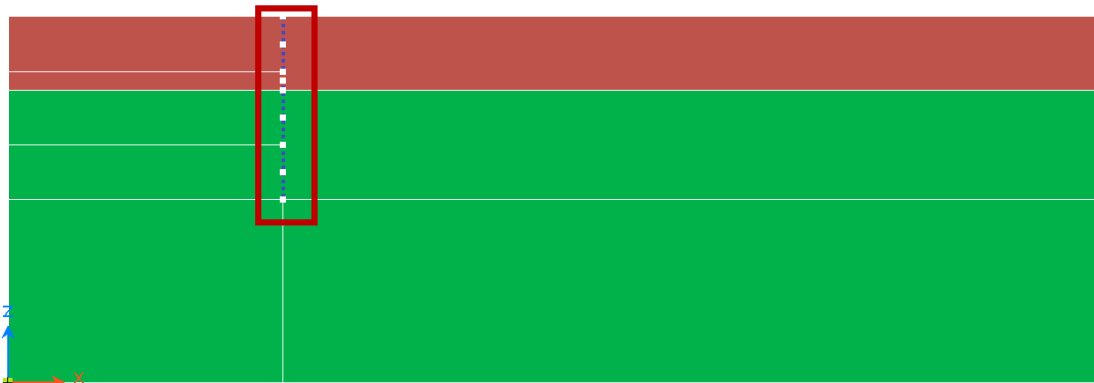

初始水位線

Loads | Boundaries 選單
Function > Water Level



Select Filter 切換到 Curve

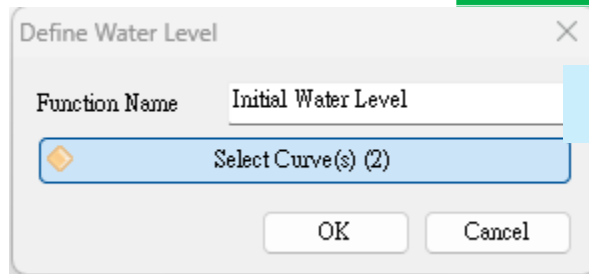
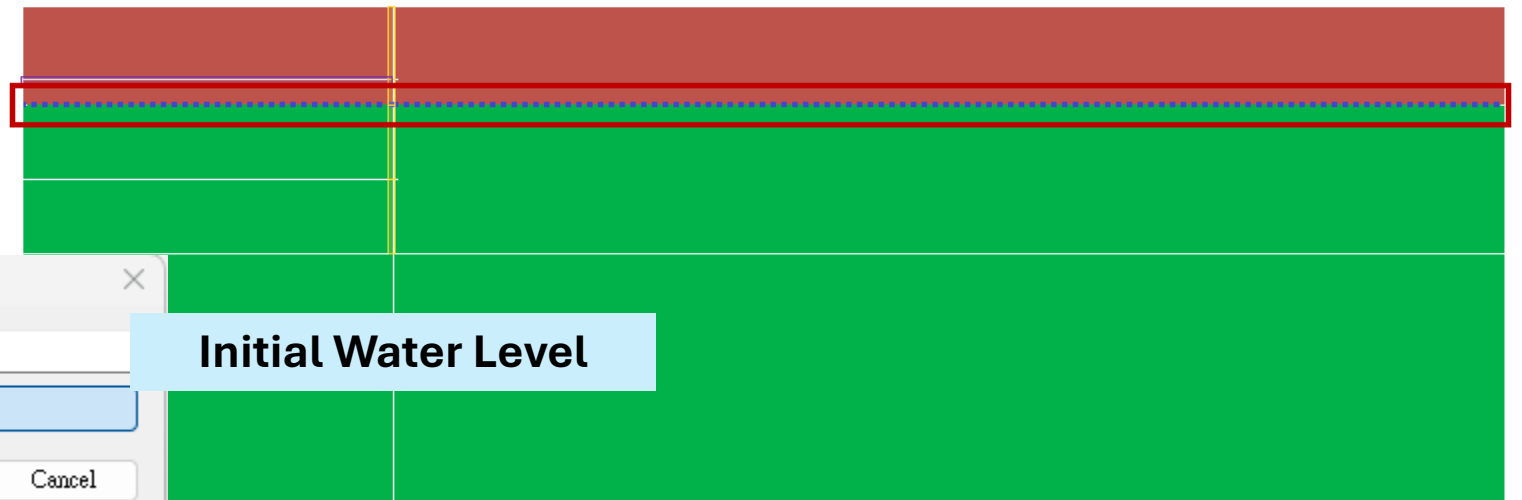
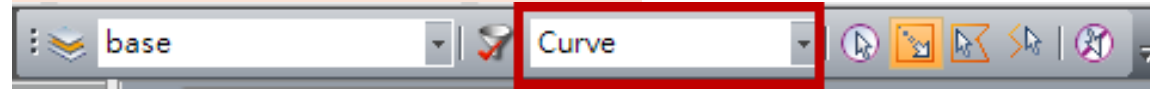

Initial Water Level

開挖後水位線

Loads | Boundaries 選單
Function > Water Level



Select Filter 切換到 Curve

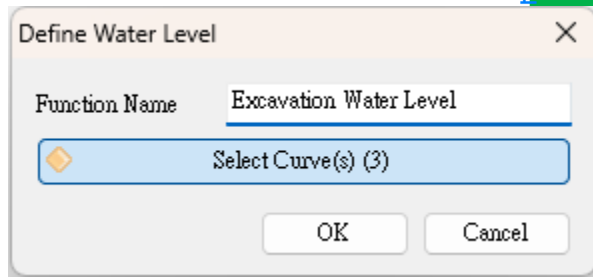
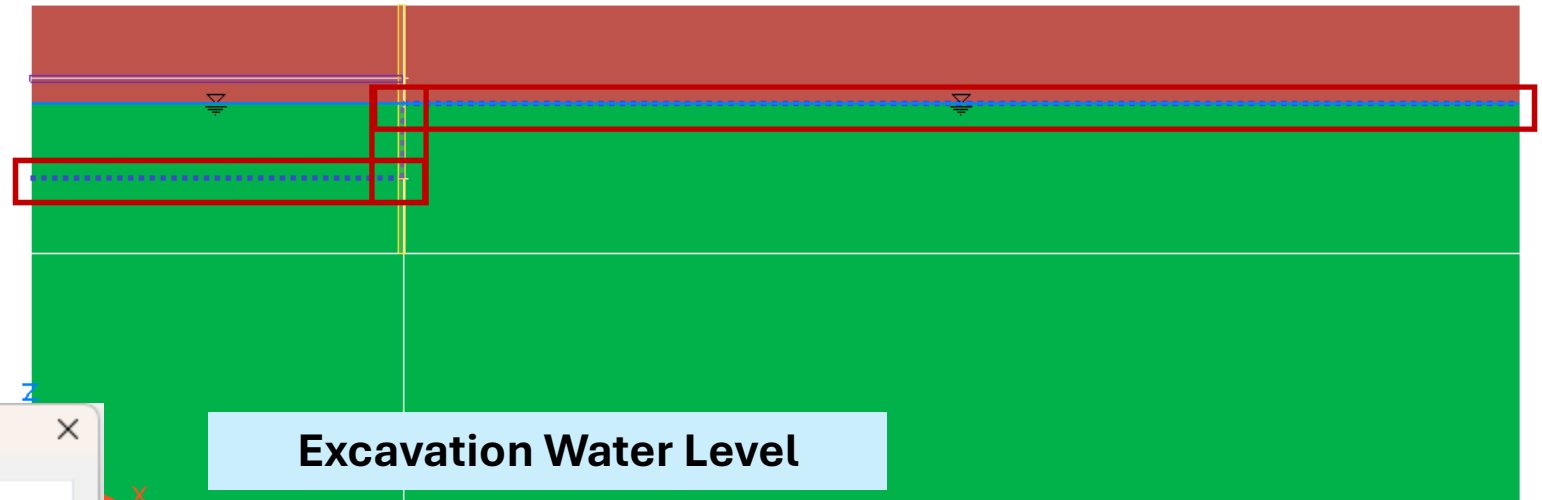
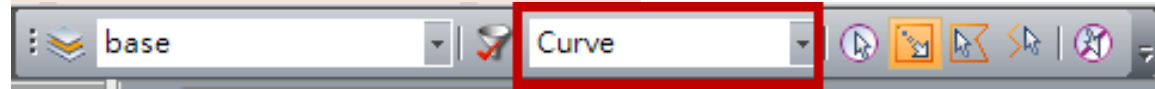

Model選單> Mesh

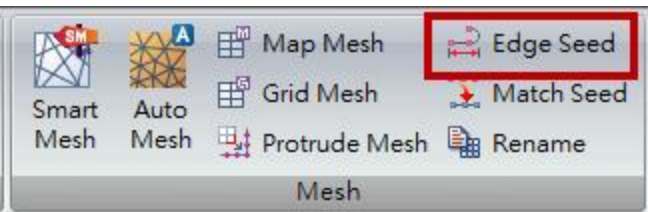

指定網格尺寸

Select Filter 切換到 Curve

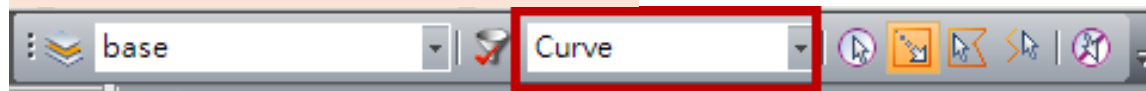

框選所有線特徵



Model選單> Mesh

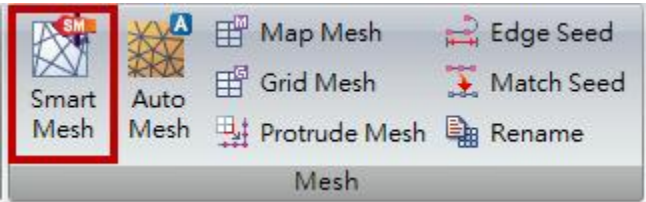

2D網格生成

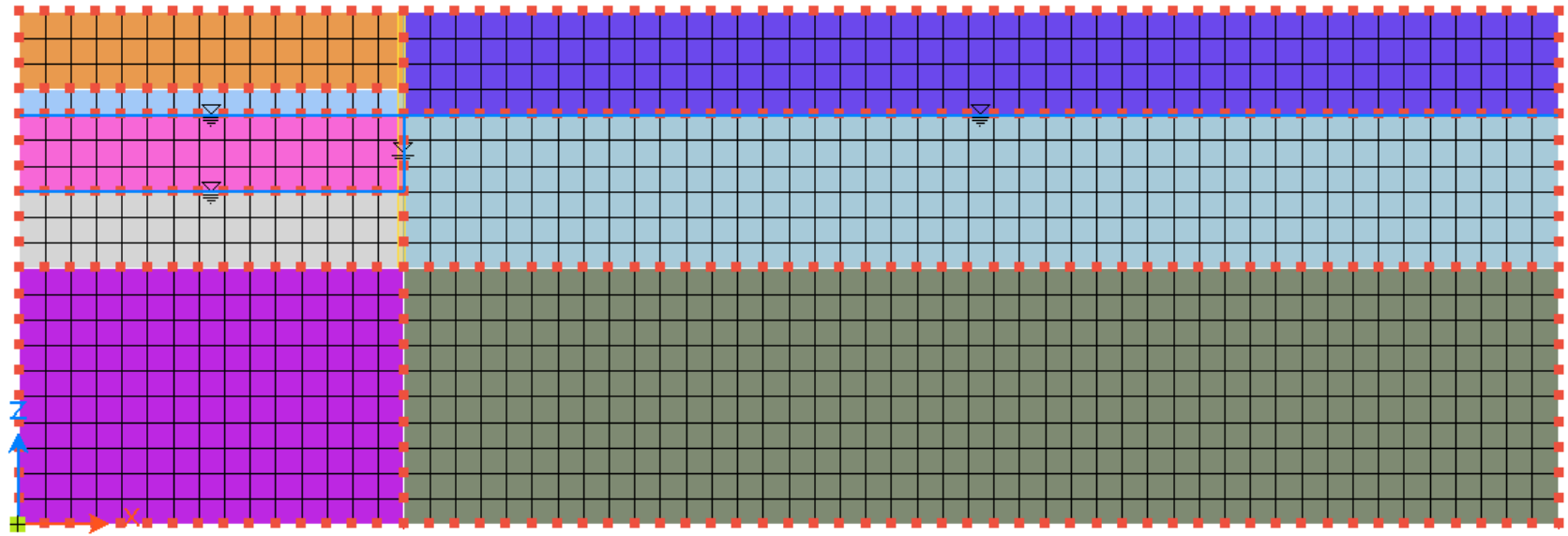
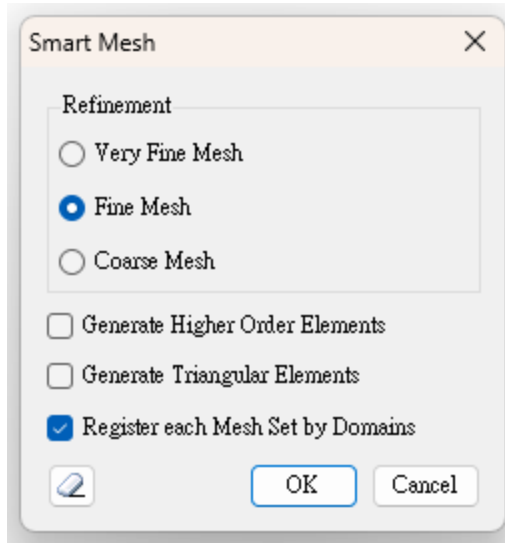

每個面特徵各別生成網格集



模型樹顯示控制(補充)

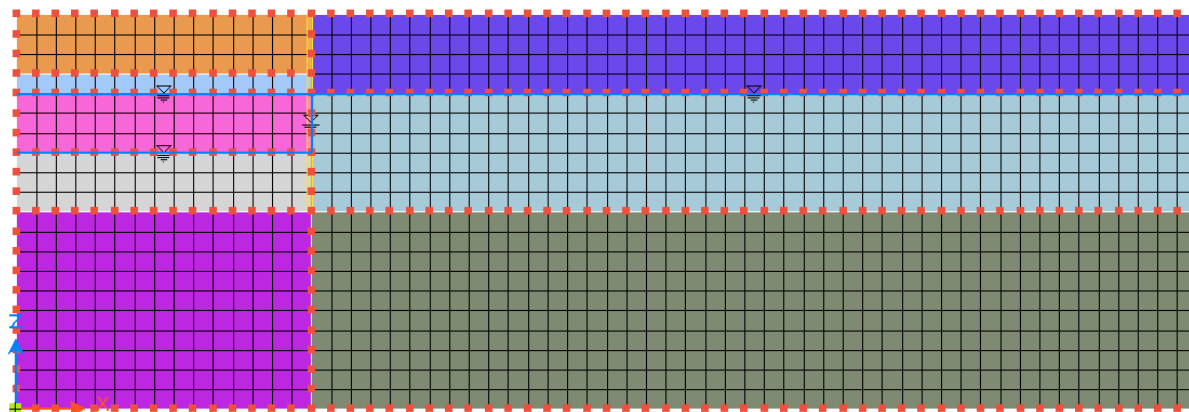
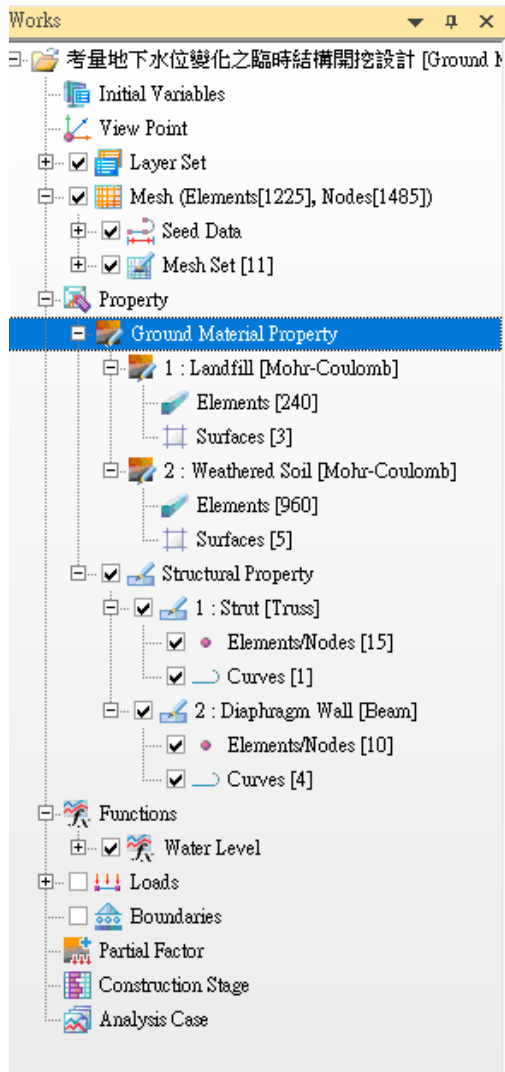

隱藏幾何特徵和網格尺寸指定顯示

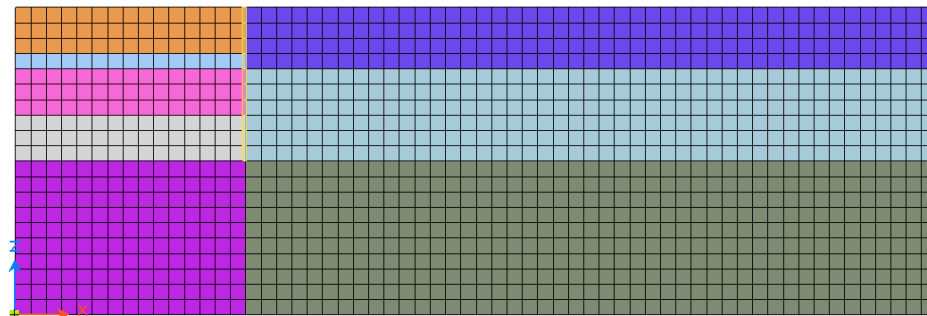
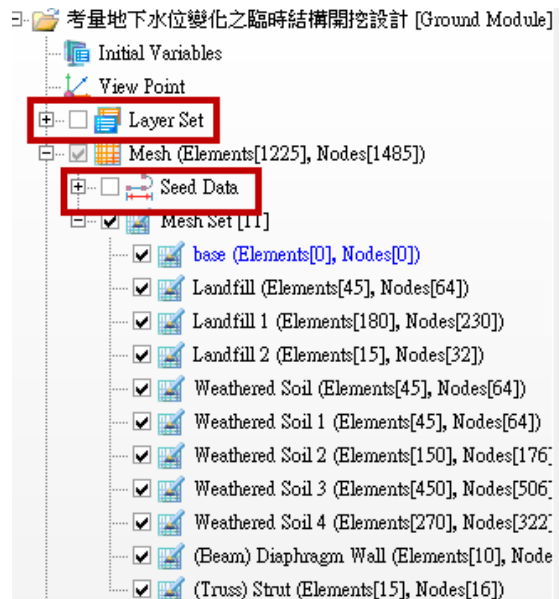

網格集名稱編輯

Select Filter 切換到 Mesh



點選網格集,按F2可以編輯名稱

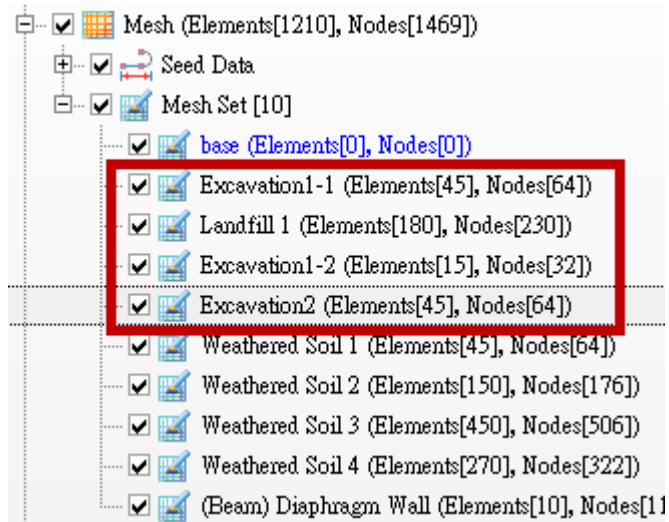

網格集名稱:Excavation 1-1

網格集名稱: Excavation 1-2

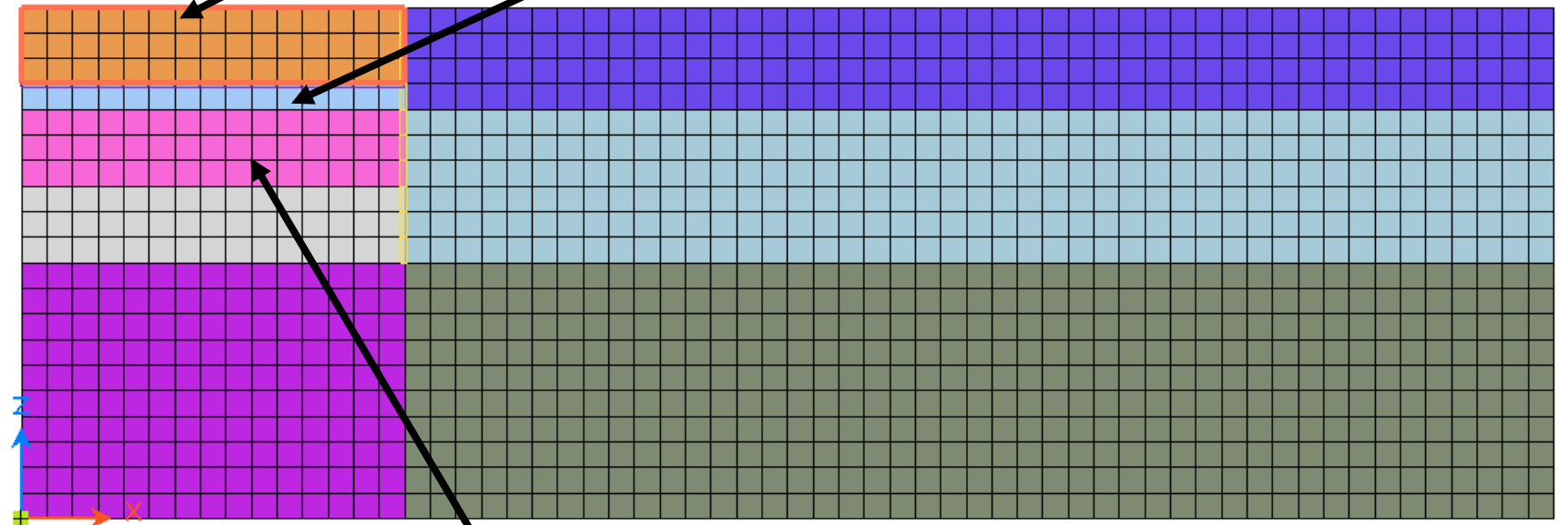

網格集名稱: Excavation 2



壓力施加

Loads | Boundaries 選單



載荷集名稱: Pressure Load

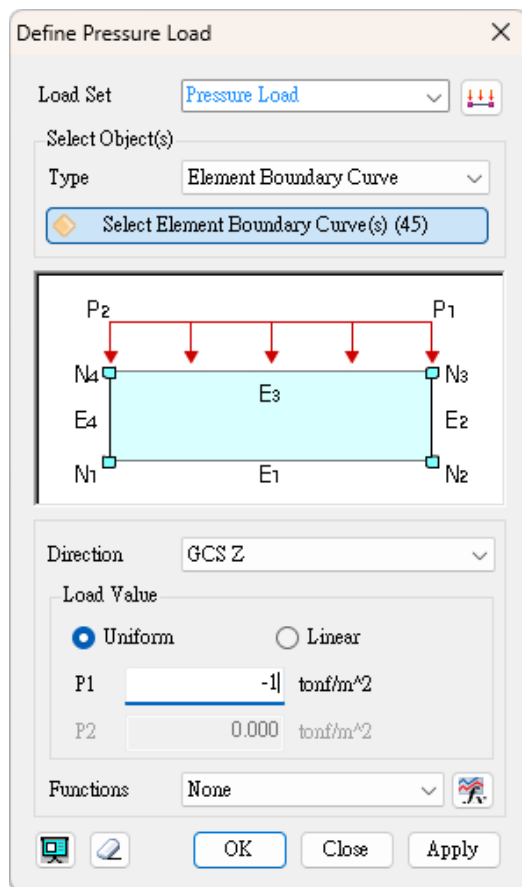

Uniform
 $P1 = -1 \text{ tonf/m}^2$

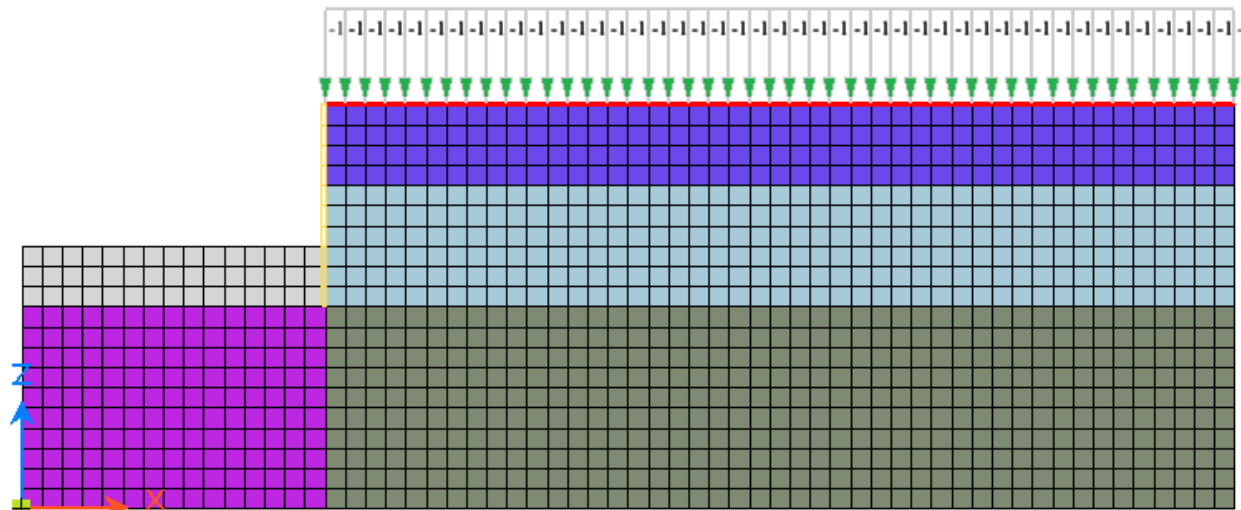

Direction : GCS Z



拘束條件

(自動判斷)

Loads | Boundaries 選單

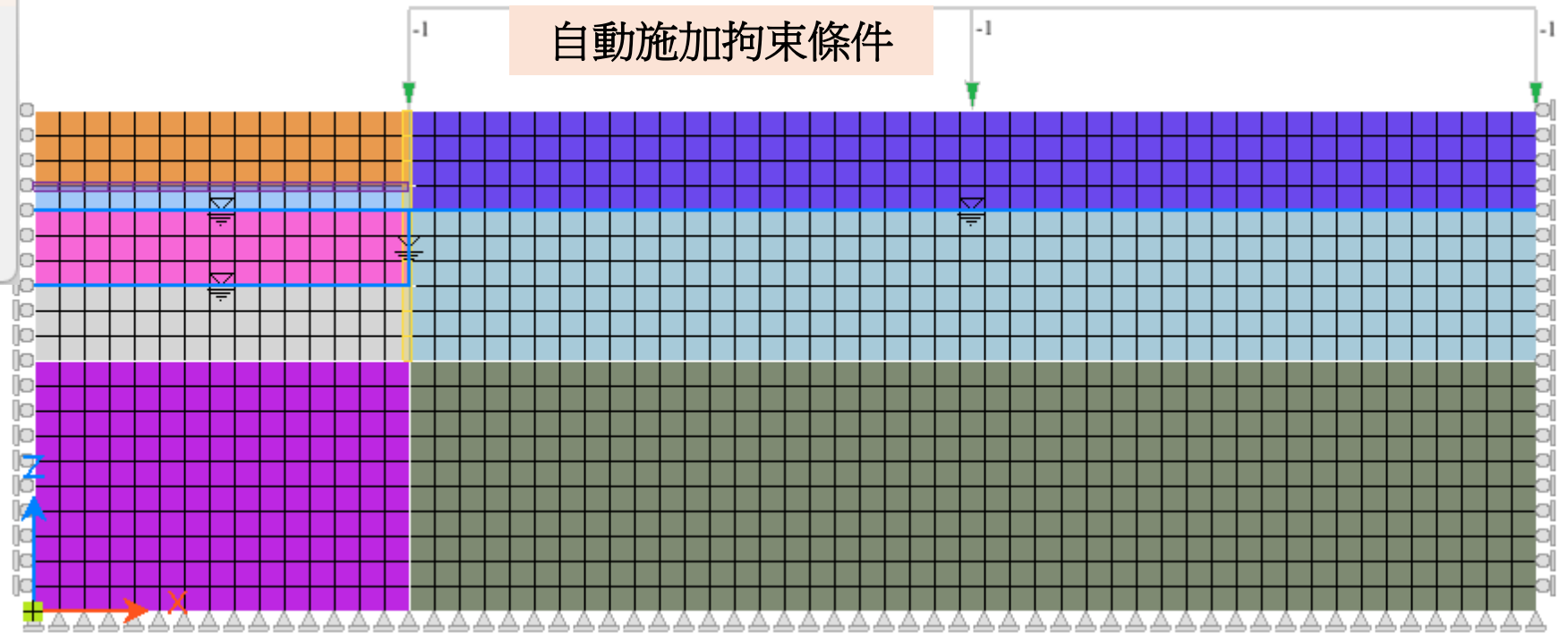
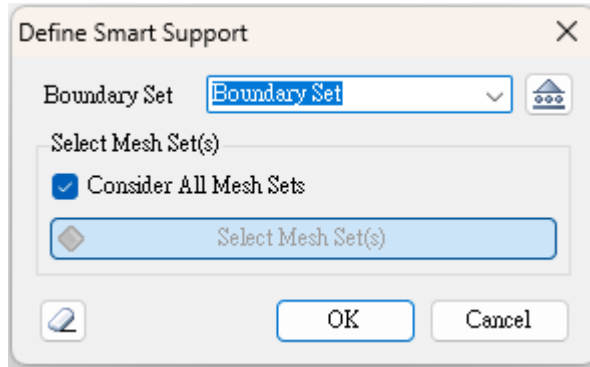

開挖計算分析說明-施工流程

(不考慮支撐)

Stage0. Initial

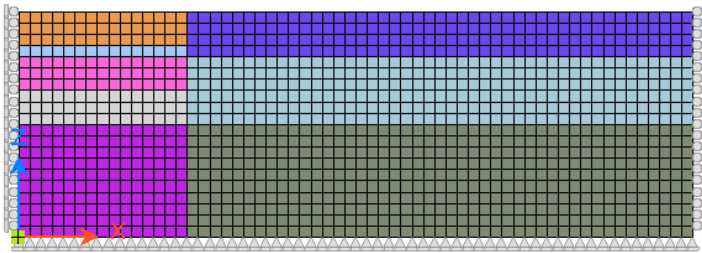

Stage1. Diaphragm Wall

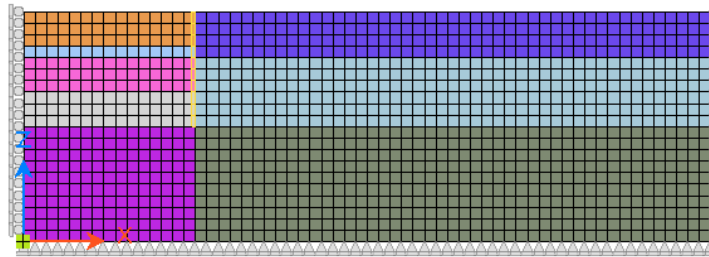

Stage2. Pressure Load

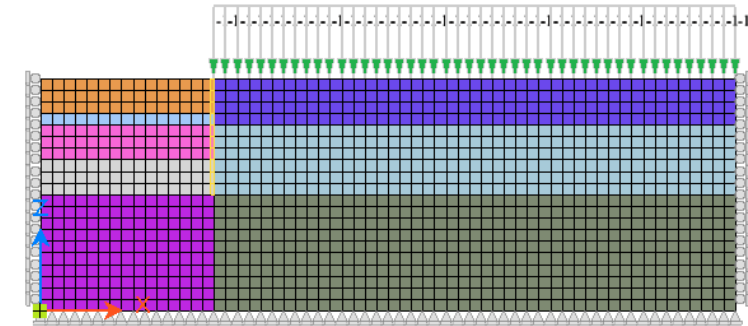

Stage3. 1st Excavation

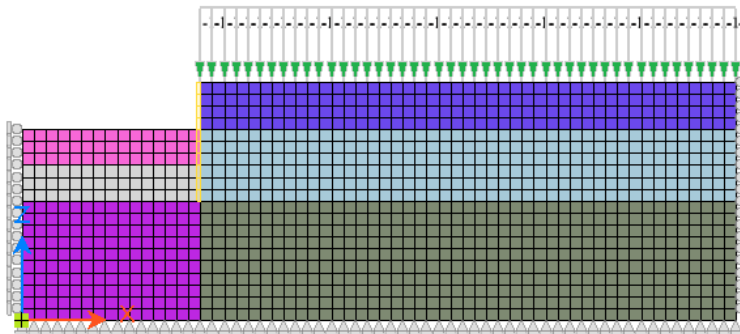

Stage4. 2nd Excavation

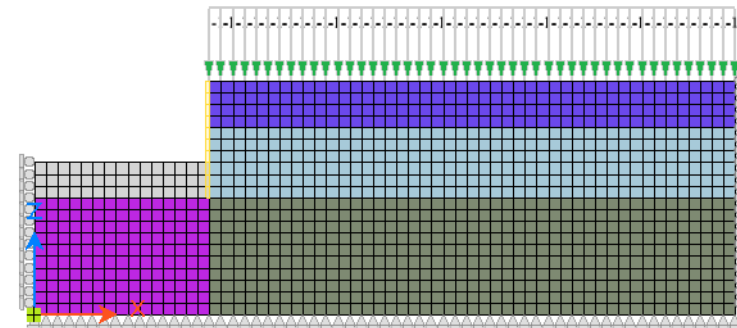

Analysis I Design選單

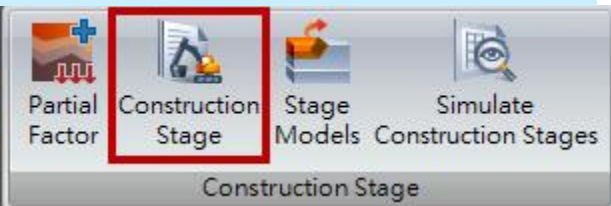

施工階段新增-1 (Stage0. Initial)

施工階段

Stage0. Initial

Stage1. Diaphragm Wall

Stage2. Pressure Load

Stage3. 1st Excavation

Stage4. 2nd Excavation

Stage0. Initial

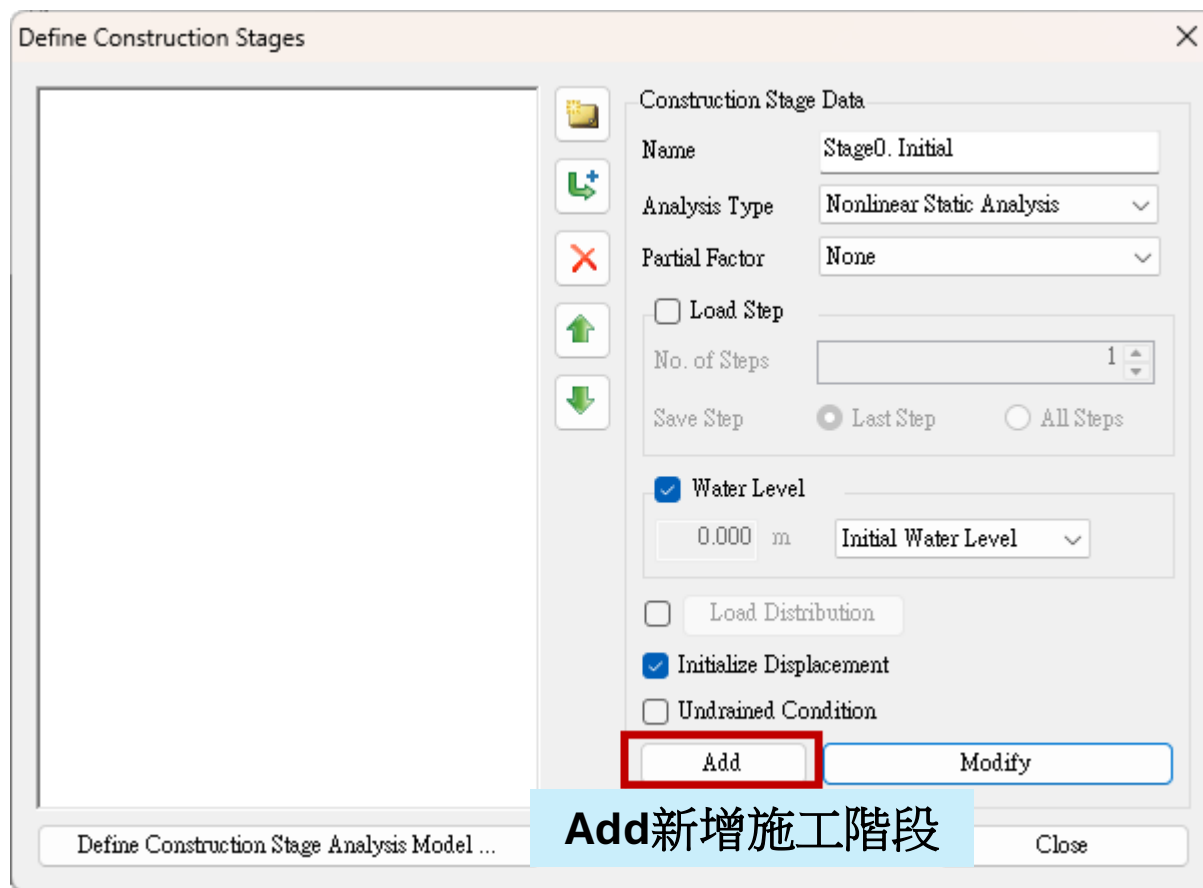

Stage0. Initial

初始水位線指定

初始位移定義

Add新增施工階段



施工階段

Stage0. Initial

Stage1. Diaphragm Wall

Stage2. Pressure Load

Stage3. 1st Excavation

Stage4. 2nd Excavation

施工階段新增-2

(Stage1. Diaphragm Wall & Stage2. Pressure Load)

Stage1. Diaphragm Wall

Define Construction Stages

Construction Stage Data

Name: Stage1. Diaphragm Wall

Analysis Type: Nonlinear Static Analysis

Partial Factor: None

Load Step

No. of Steps: 1

Save Step: Last Step All Steps

Water Level

0.000 m Initial Water Level

Load Distribution

Initialize Displacement

Undrained Condition

Add Modify

Define Construction Stage Analysis Model ... Close

Stage2. Pressure Load

Define Construction Stages

Construction Stage Data

Name: Stage2. Pressure Load

Analysis Type: Nonlinear Static Analysis

Partial Factor: None

Load Step

No. of Steps: 1

Save Step: Last Step All Steps

Water Level

0.000 m Initial Water Level

Load Distribution

Initialize Displacement

Undrained Condition

Add Modify

Define Construction Stage Analysis Model ... Close



施工階段

Stage0. Initial

Stage1. Diaphragm Wall

Stage2. Pressure Load

Stage3. 1st Excavation

Stage4. 2nd Excavation

施工階段新增-3

(Stage3. 1st Excavation & Stage4. 2nd Excavation)

Stage3. 1st Excavation

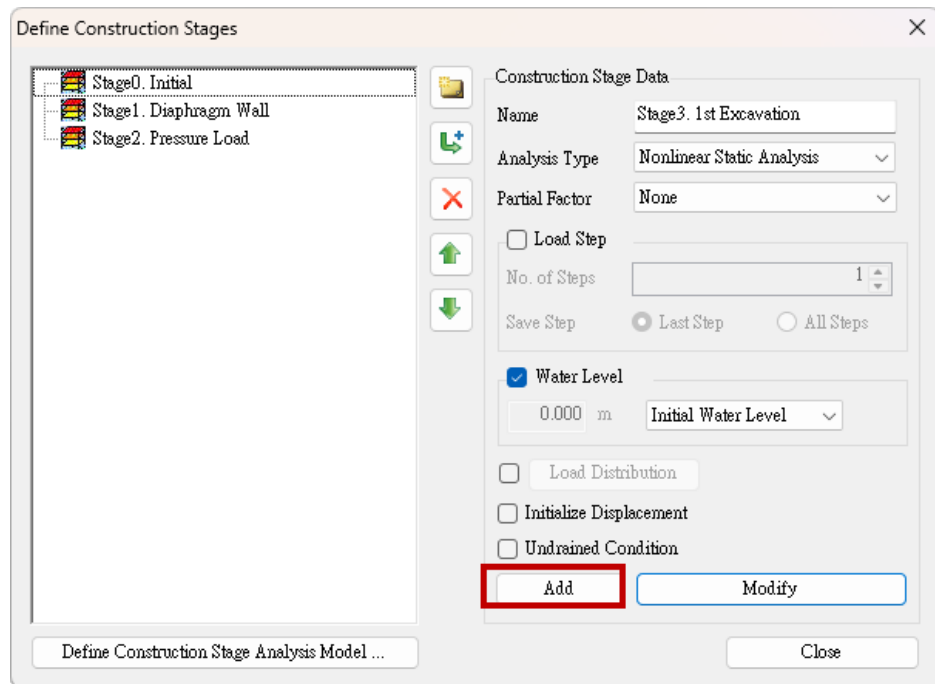

Stage4. 2nd Excavation

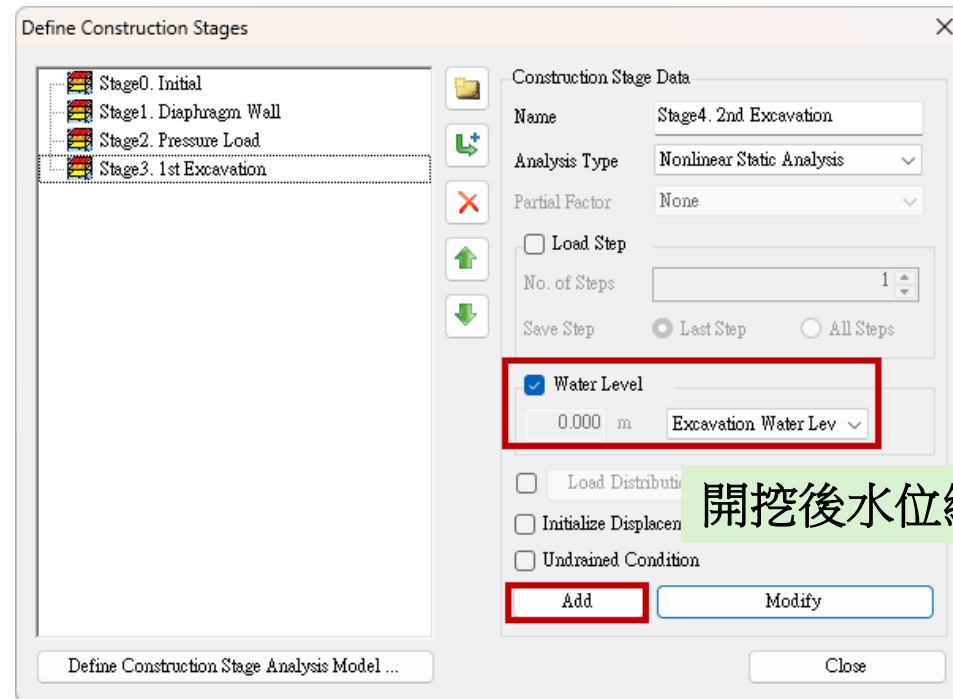



施工階段編輯-1

(Stage0. Initial)

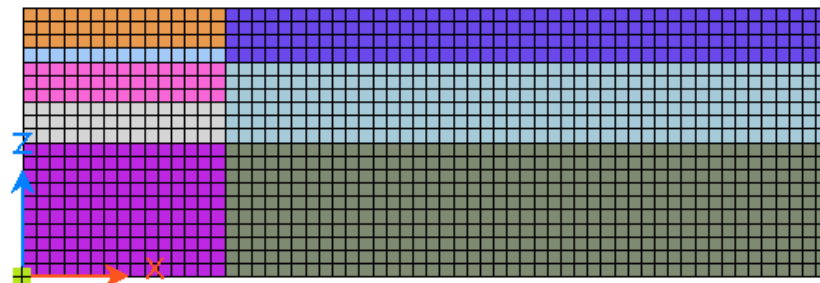
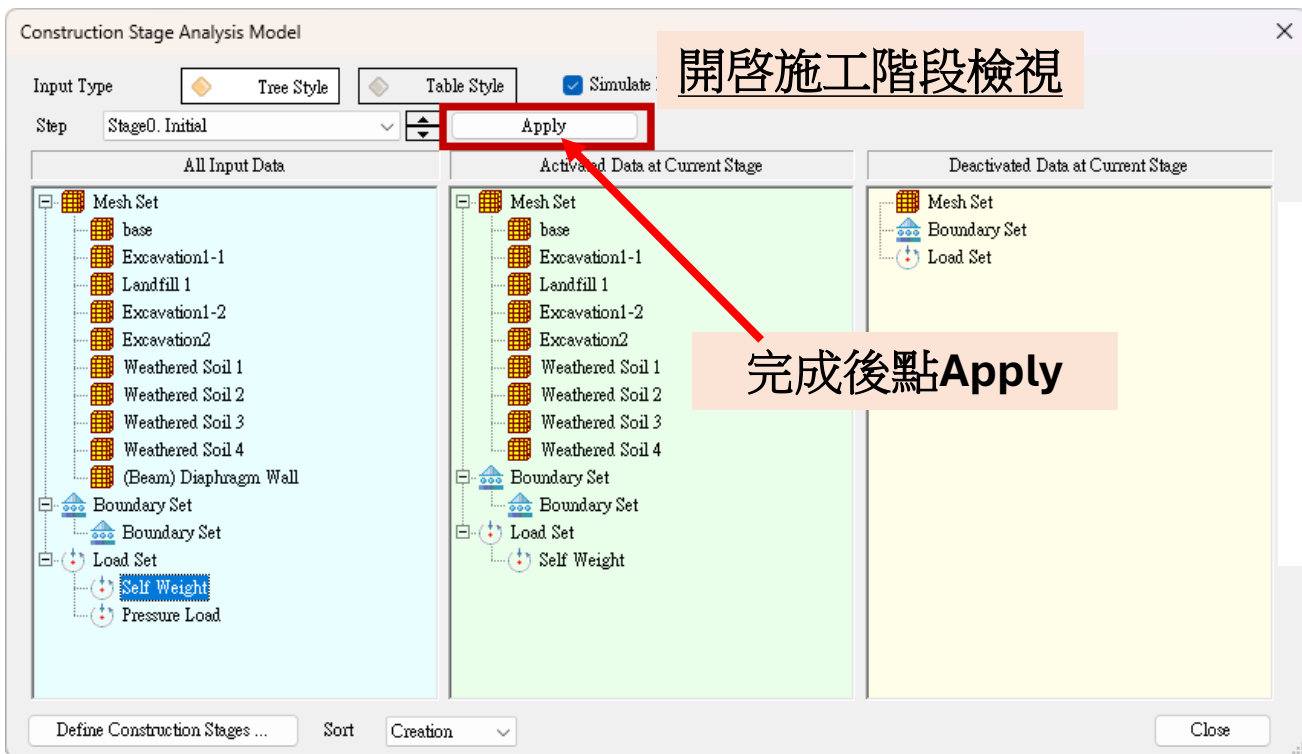

拖曳全部土壤(含開挖區域)網格集/邊界集/Self Weight 載荷集



施工階段編輯-2

(Stage1. Diaphragm Wall & Stage2. Pressure Load)

切換到Stage1. Diaphragm Wall

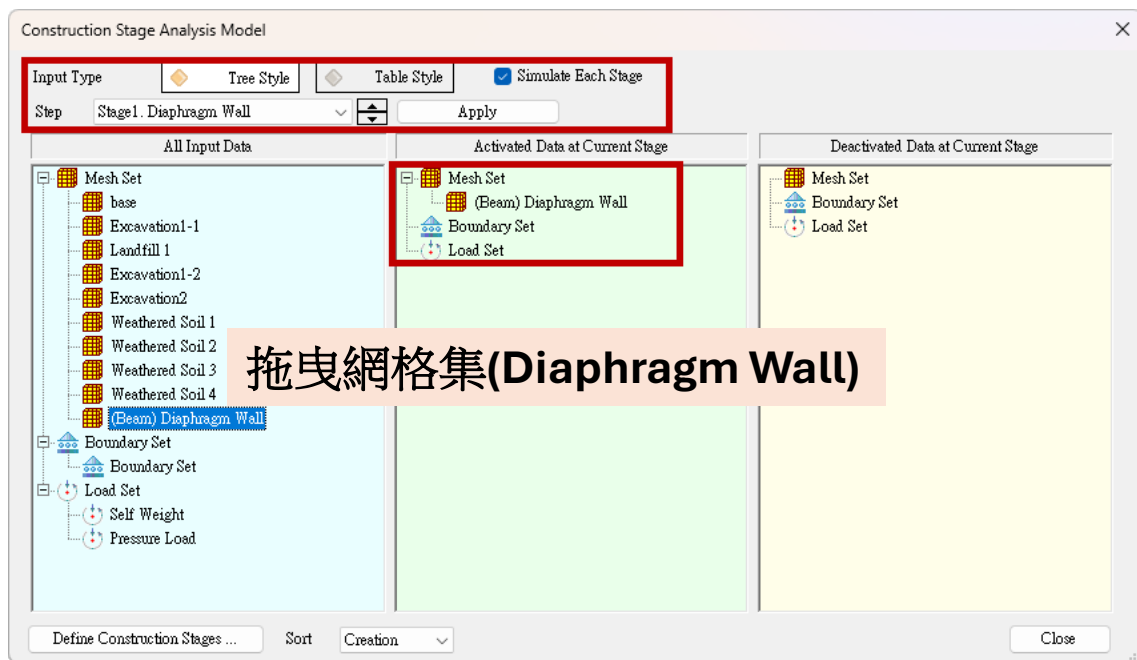

切換到Stage2. Pressure Load

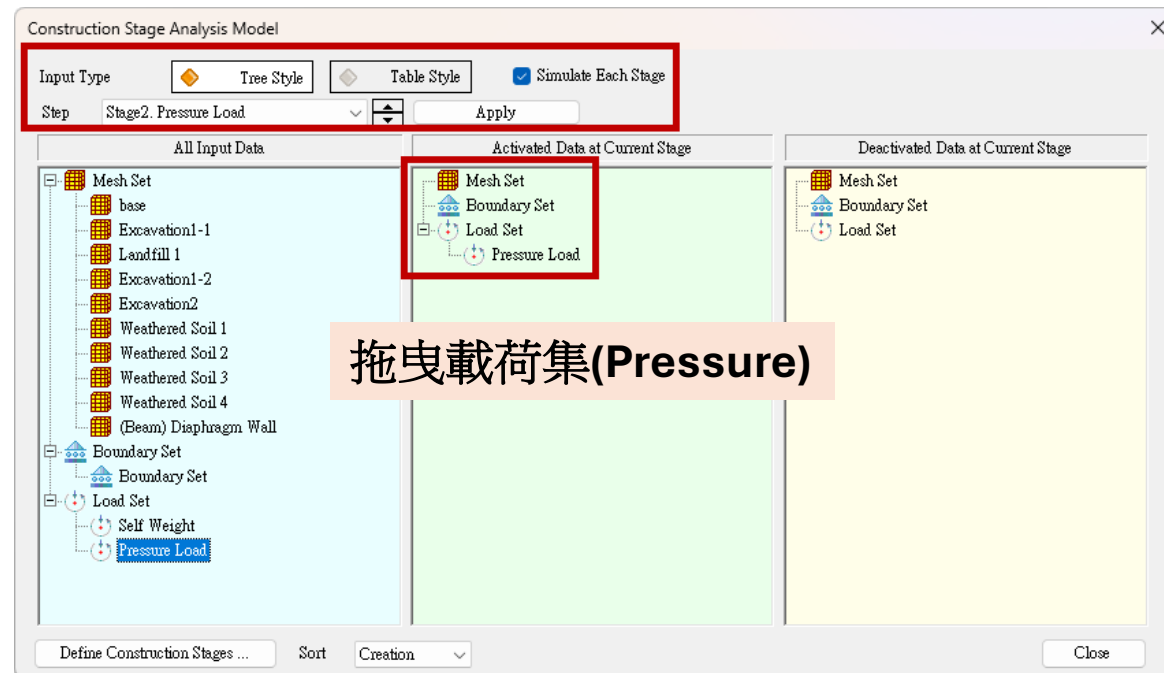

施工階段編輯-3

(Stage3. 1st Excavation & Stage4. 2nd Excavation)

切換到Stage3. 1st Excavation

切換到Stage4. 2nd Excavation

Construction Stage Analysis Model

Input Type: Tree Style Table Style Simulate Each Stage

Step: Stage3. 1st Excavation Apply

All Input Data: Mesh Set (base, Excavation1-1, Landfill 1, Excavation1-2, Excavation2, Weathered Soil 1-4, (Beam) Diaphragm Wall), Self Weight, Pressure Load

Activated Data at Current Stage: Mesh Set (Boundary Set, Load Set)

Deactivated Data at Current Stage: Mesh Set (Excavation1-1, Excavation1-2), Boundary Set, Load Set

Define Construction Stages ... Sort Creation Close

拖曳網格集(Excavation1-1&1-2)=>Deactivated Data

Construction Stage Analysis Model

Input Type: Tree Style Table Style Simulate Each Stage

Step: Stage4. 2nd Excavation Apply

All Input Data: Mesh Set (base, Excavation1-1, Landfill 1, Excavation1-2, Excavation2, Weathered Soil 1-4, (Beam) Diaphragm Wall), Boundary Set, Load Set, Self Weight, Pressure Load

Activated Data at Current Stage: Mesh Set (Boundary Set, Load Set)

Deactivated Data at Current Stage: Mesh Set (Excavation2), Boundary Set, Load Set

Define Construction Stages ... Sort Creation Close

拖曳網格集(Excavation 2)=>Deactivated Data

分析定義

分析名稱:Excavation/分析類型:Construction Stage

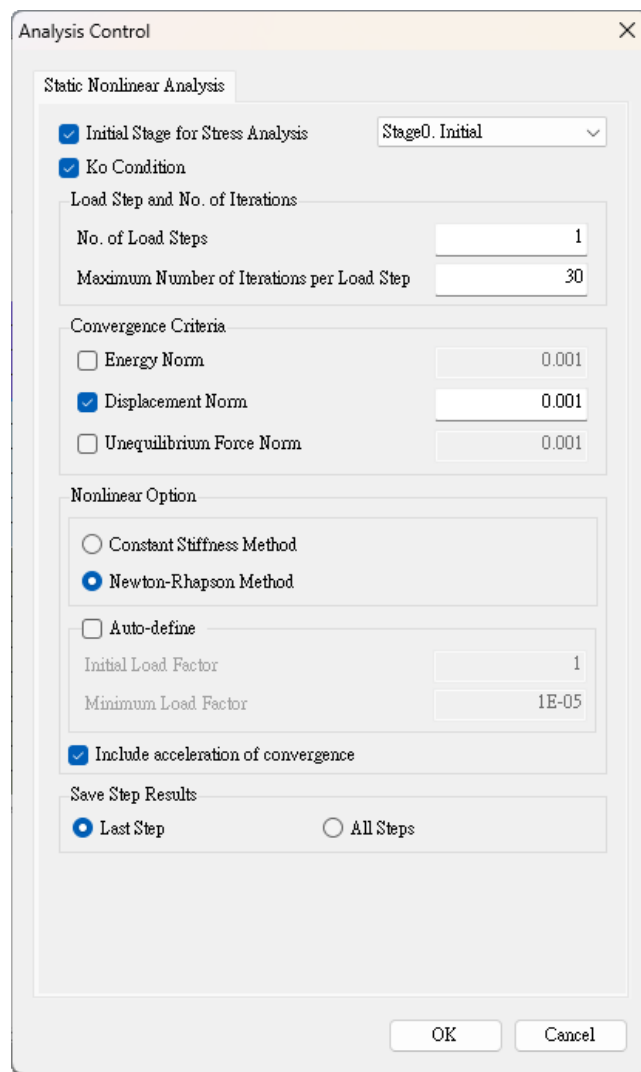
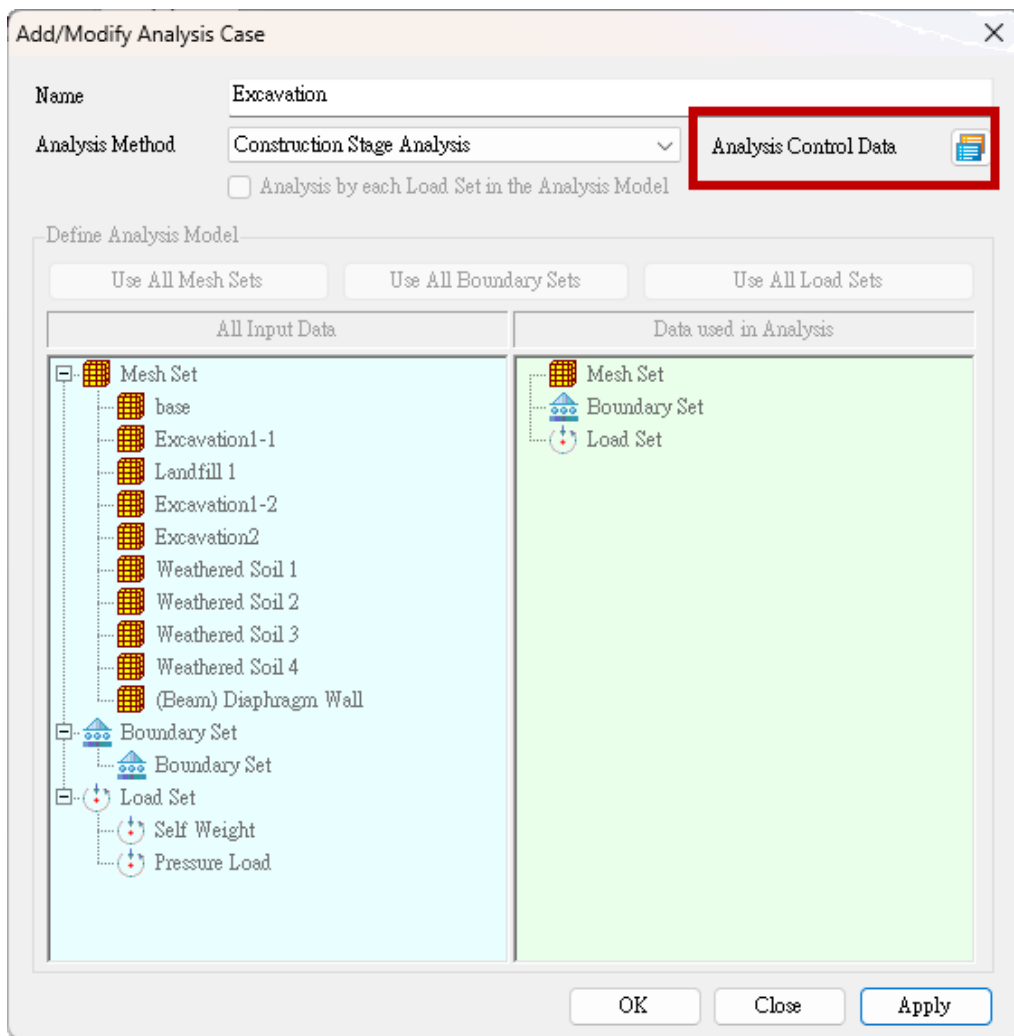
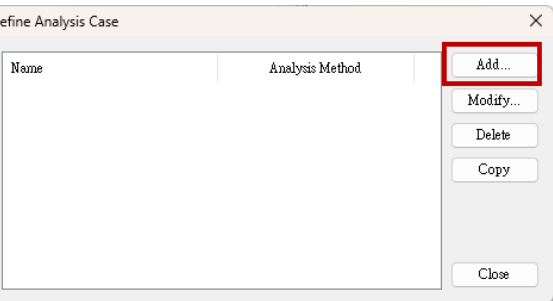
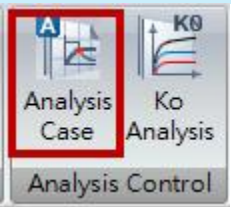

計算

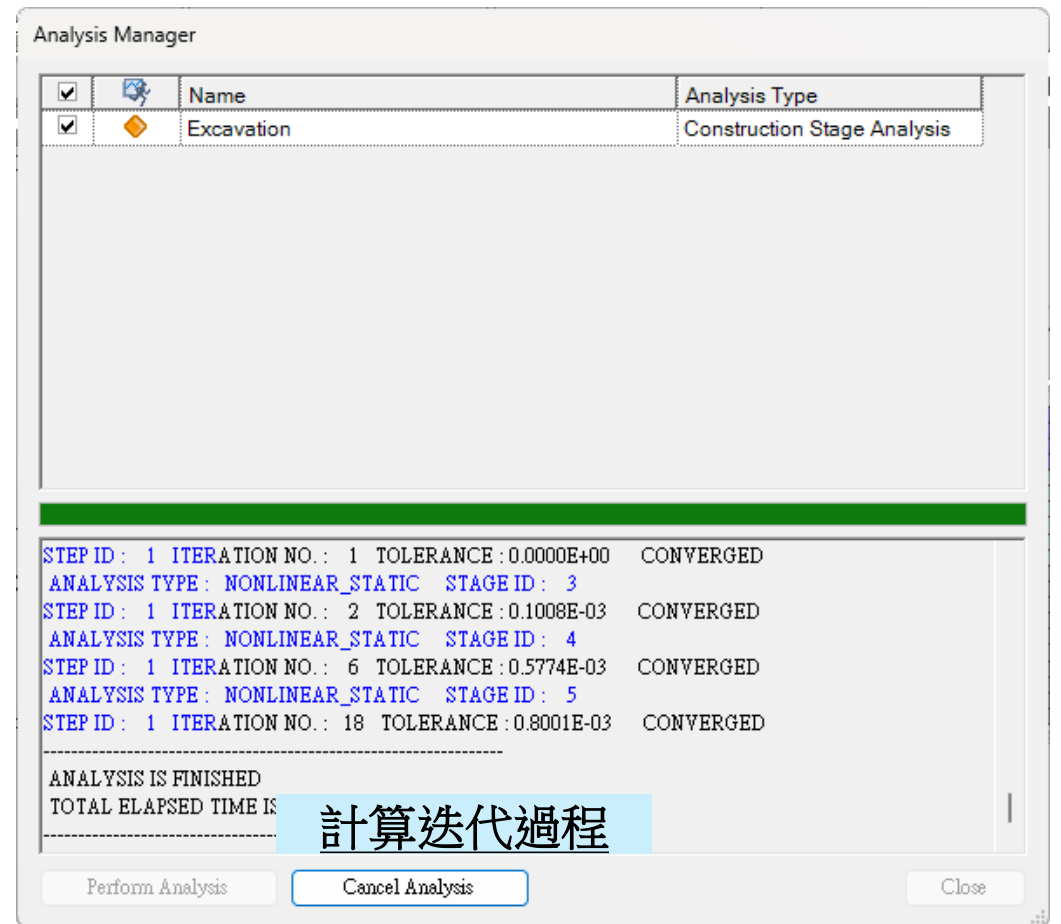
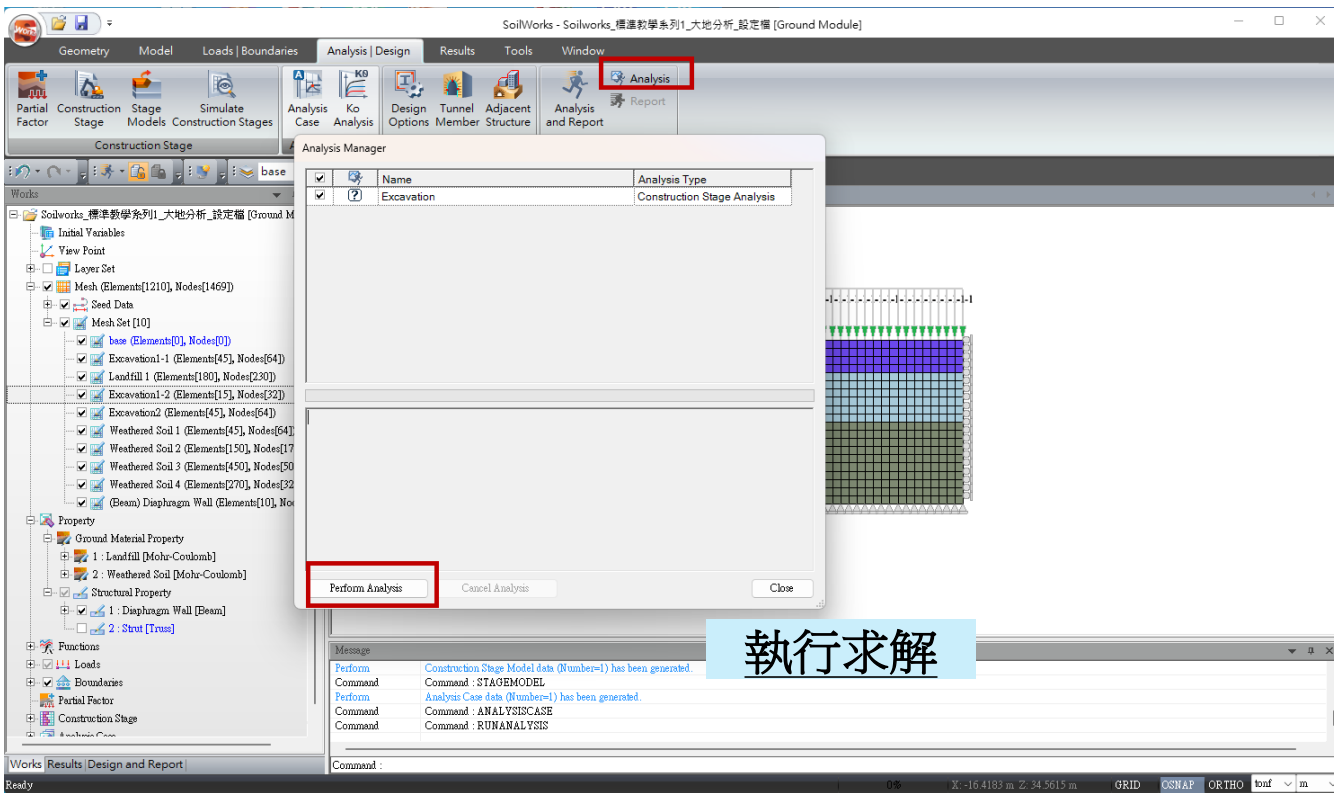

依照施工階段定義順序 輸出5組結果

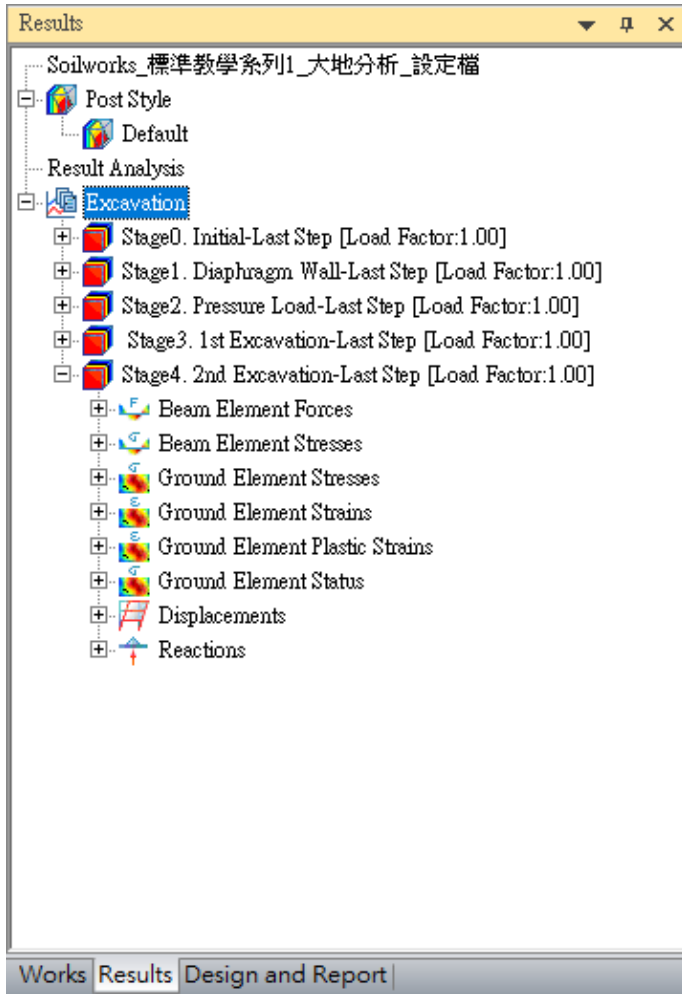

分析結果

各類分析顯示定義

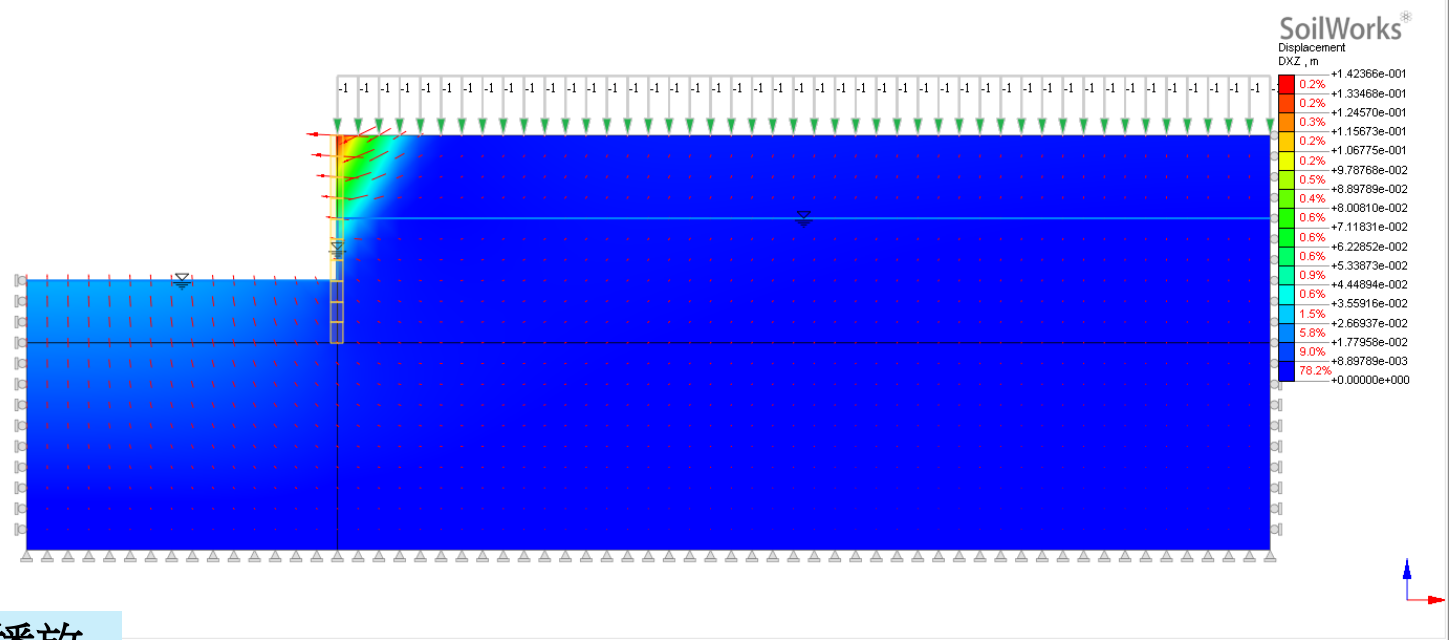

影片播放



開挖計算

(考慮支撐)



開挖計算分析說明-施工流程

(考慮支撐)

Stage0. Initial

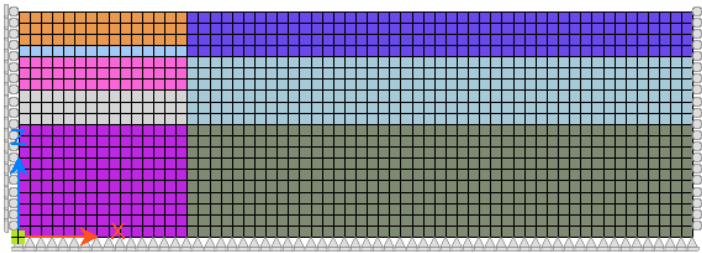

Stage1. Diaphragm Wall

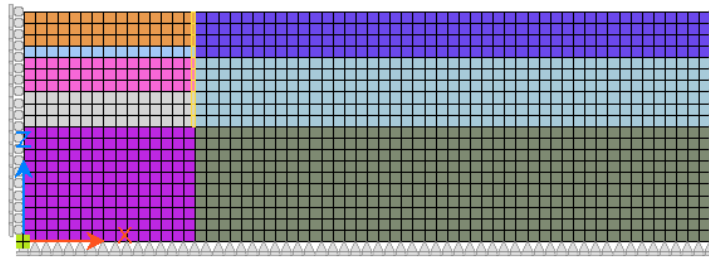

Stage2. Pressure Load

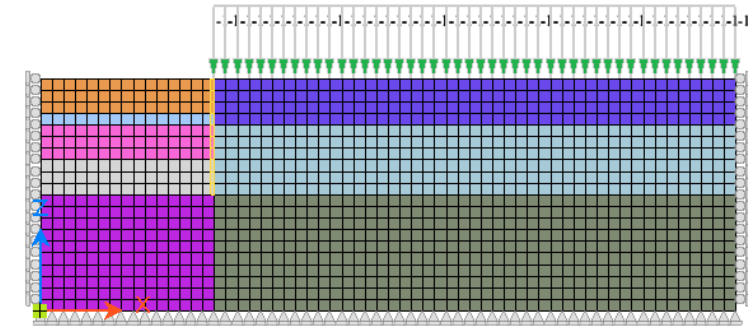

Stage3. 1st Excavation

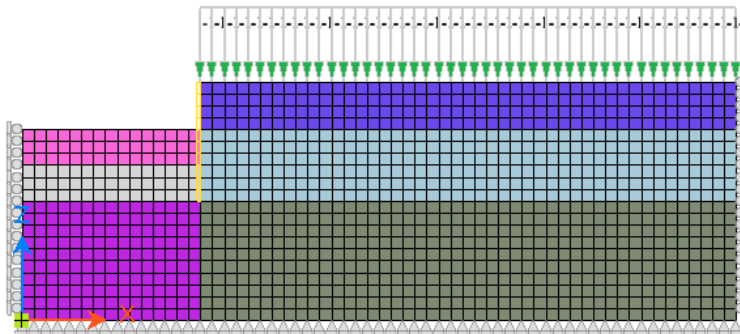

Stage4. 2nd Excavation

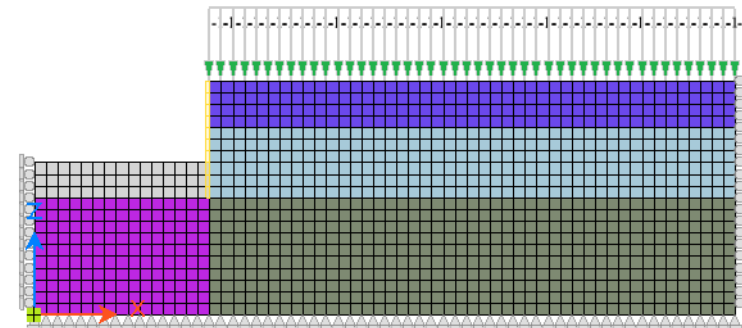

支撐元素手動新增

Model 選單

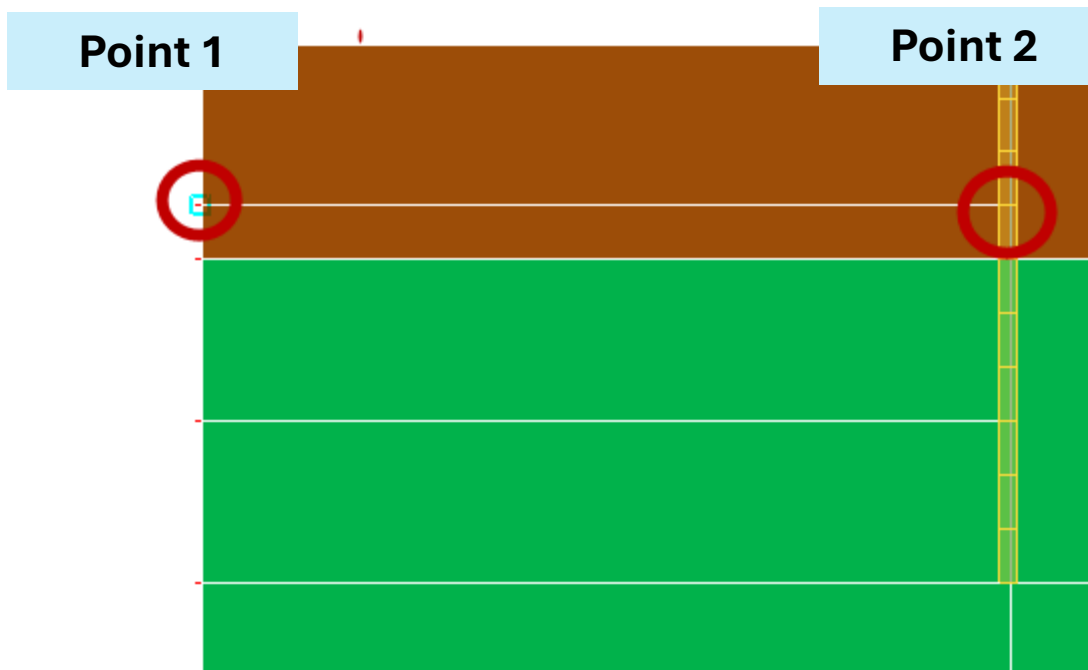
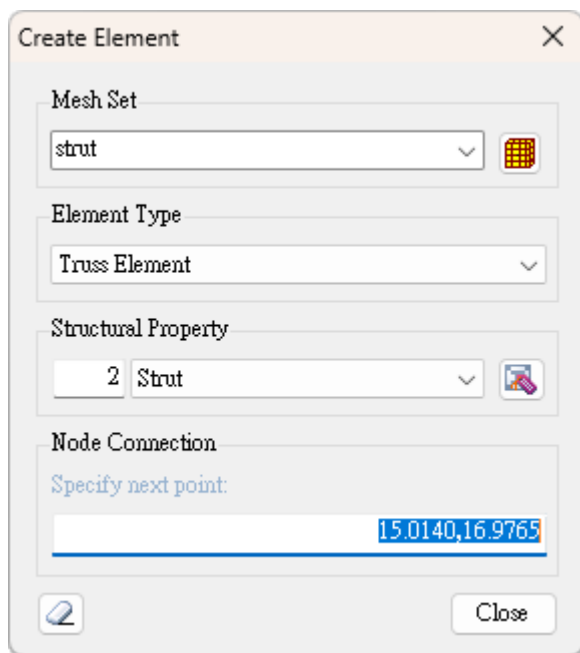
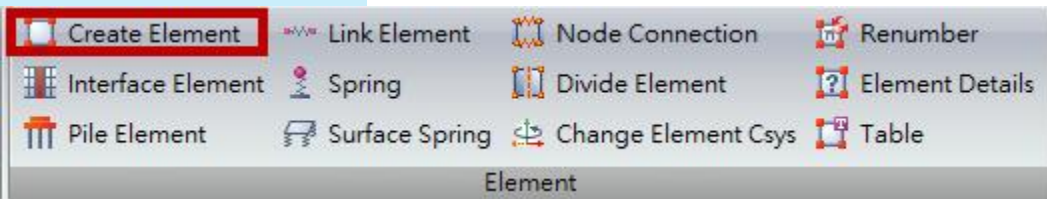

合併節點

Model 選單

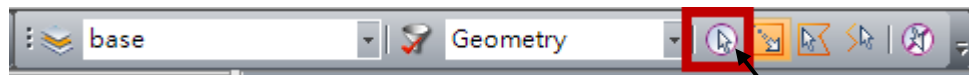
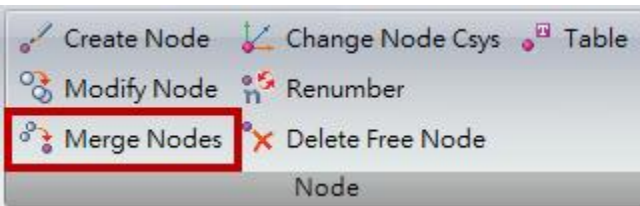

選取所有節點

顯示網格集(不含開挖區域)

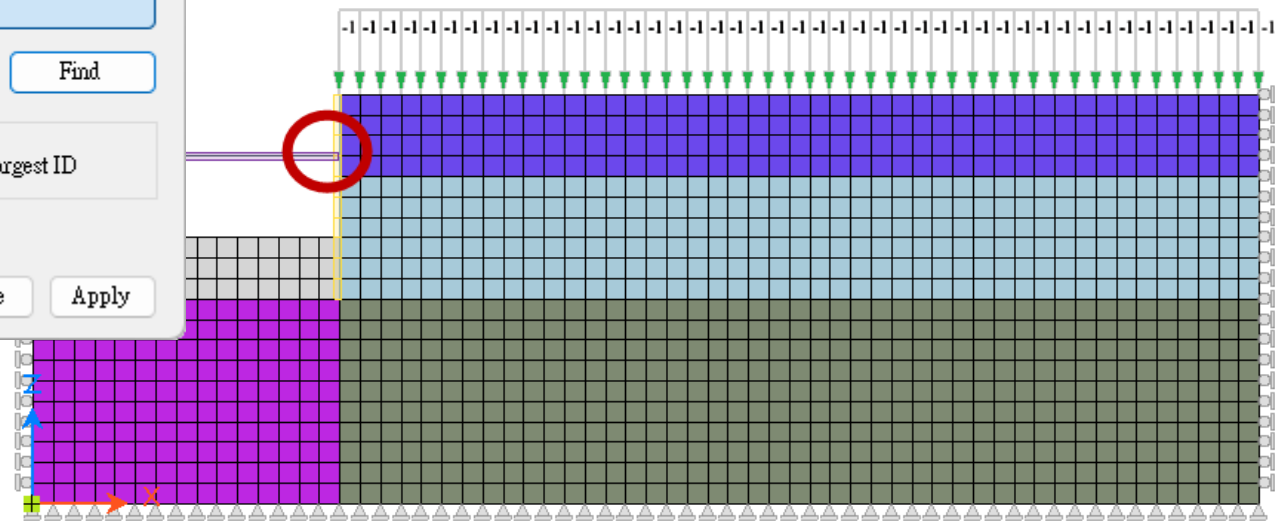
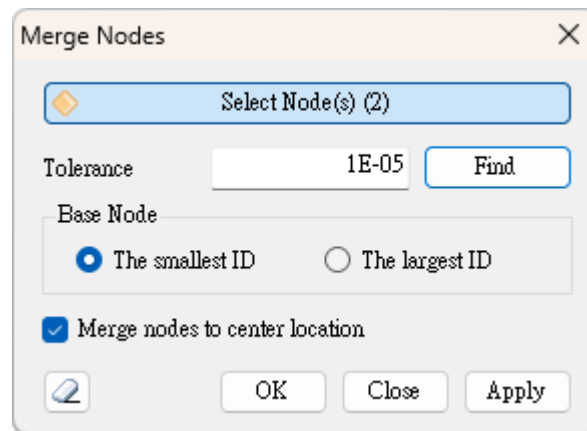
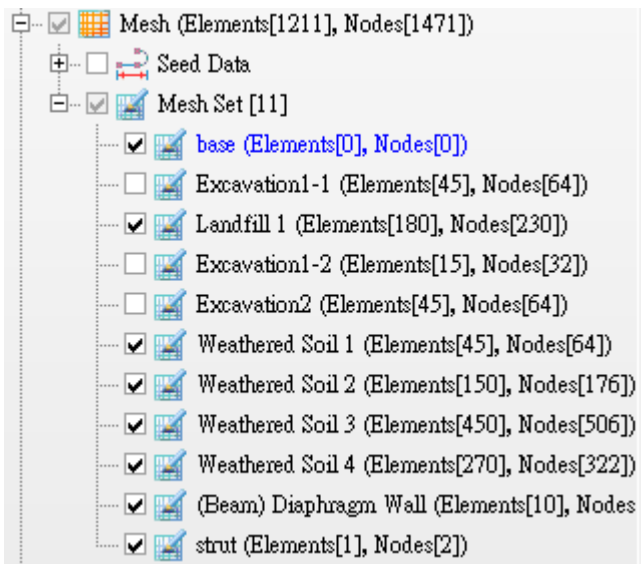

支撐元素邊界條件

Loads | Boundaries 選單

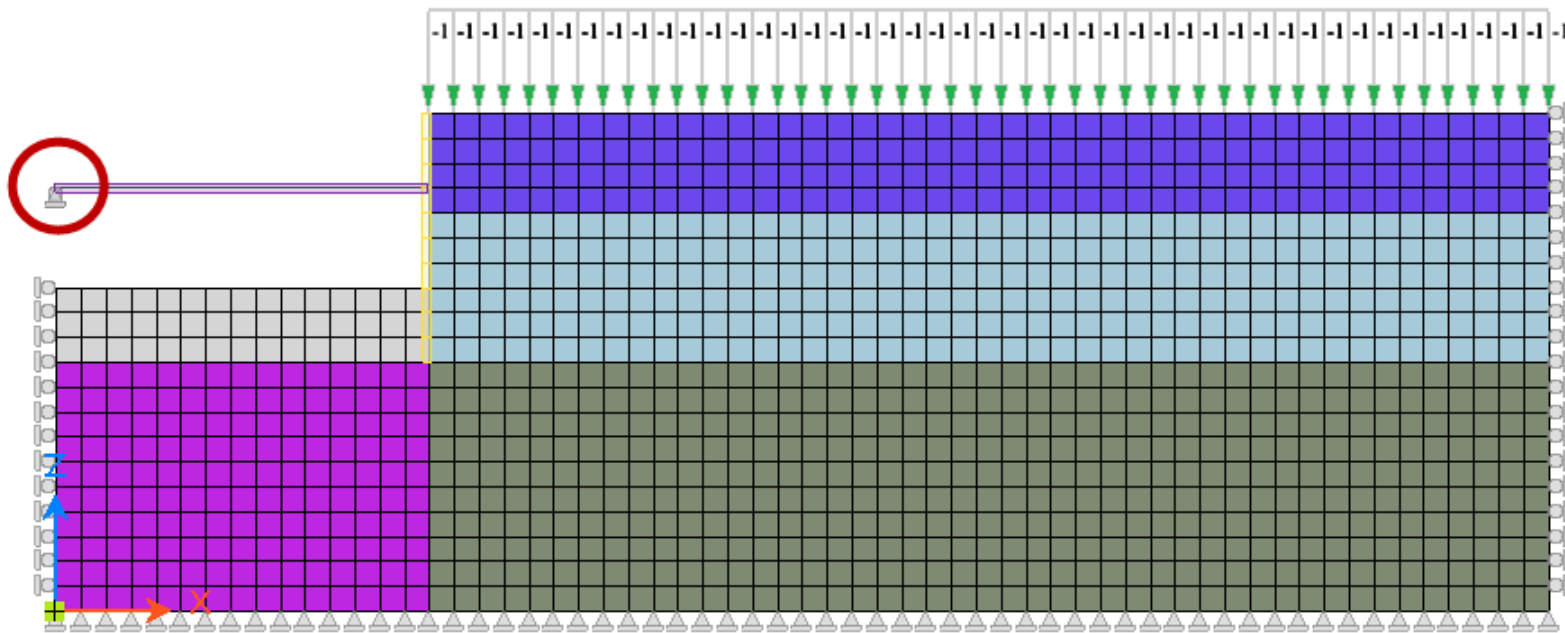
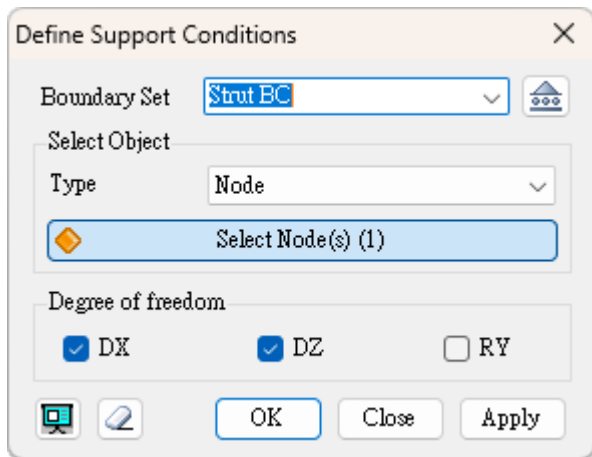
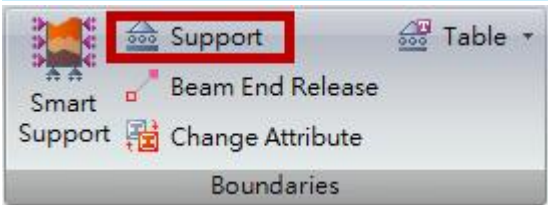



施工階段編輯-添加支撐

(Stage3. 1st Excavation)

切換到Stage3. 1st Excavation

Construction Stage Analysis Model

Input Type: Tree Style Table Style Simulate Each Stage

Step: Stage3. 1st Excavation Apply

All Input Data	Activated Data at Current Stage	Deactivated Data at Current Stage
<ul style="list-style-type: none">Mesh Set<ul style="list-style-type: none">baseExcavation1-1Landfill 1Excavation1-2Excavation2Weathered Soil 1Weathered Soil 2Weathered Soil 3Weathered Soil 4(Beam) DiaphragmStrutBoundary Set<ul style="list-style-type: none">Boundary SetBoundary SetStrut BCLoad Set<ul style="list-style-type: none">Self WeightPressure Load	<ul style="list-style-type: none">Mesh Set<ul style="list-style-type: none">strutBoundary Set<ul style="list-style-type: none">Strut BCLoad Set	<ul style="list-style-type: none">Mesh Set<ul style="list-style-type: none">Excavation1-1Excavation1-2Boundary SetLoad Set

Define Construction Stages ... Sort Creation Close

拖曳網格集(Strut)=>Activated Data

拖曳邊界集(Strut BC)=>Activated Data



依照施工階段定義順序 輸出5組結果

分析結果

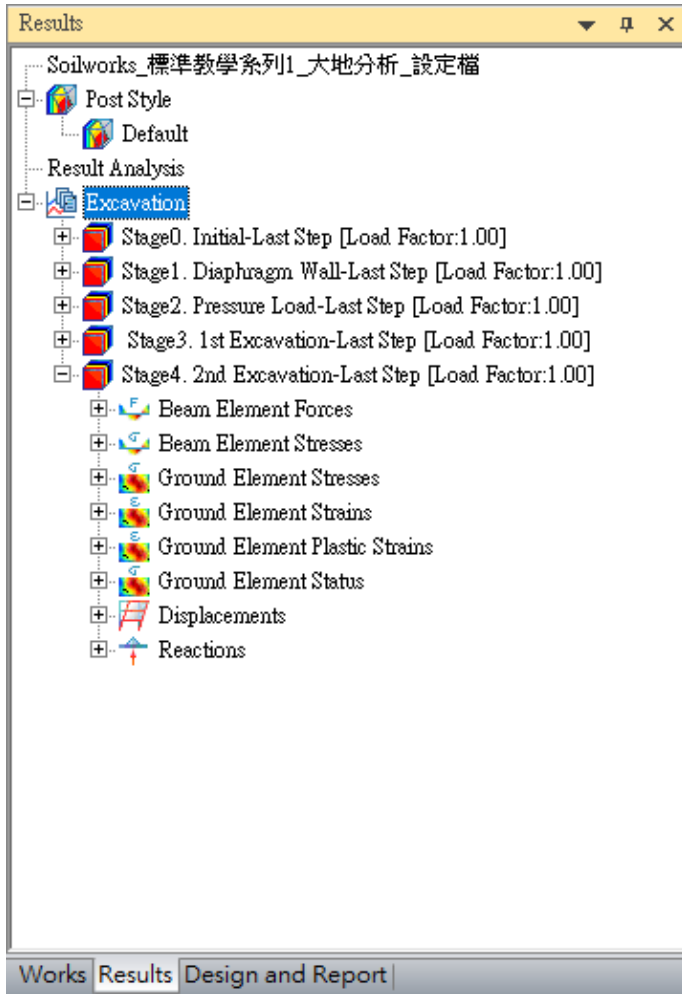

各類分析顯示定義

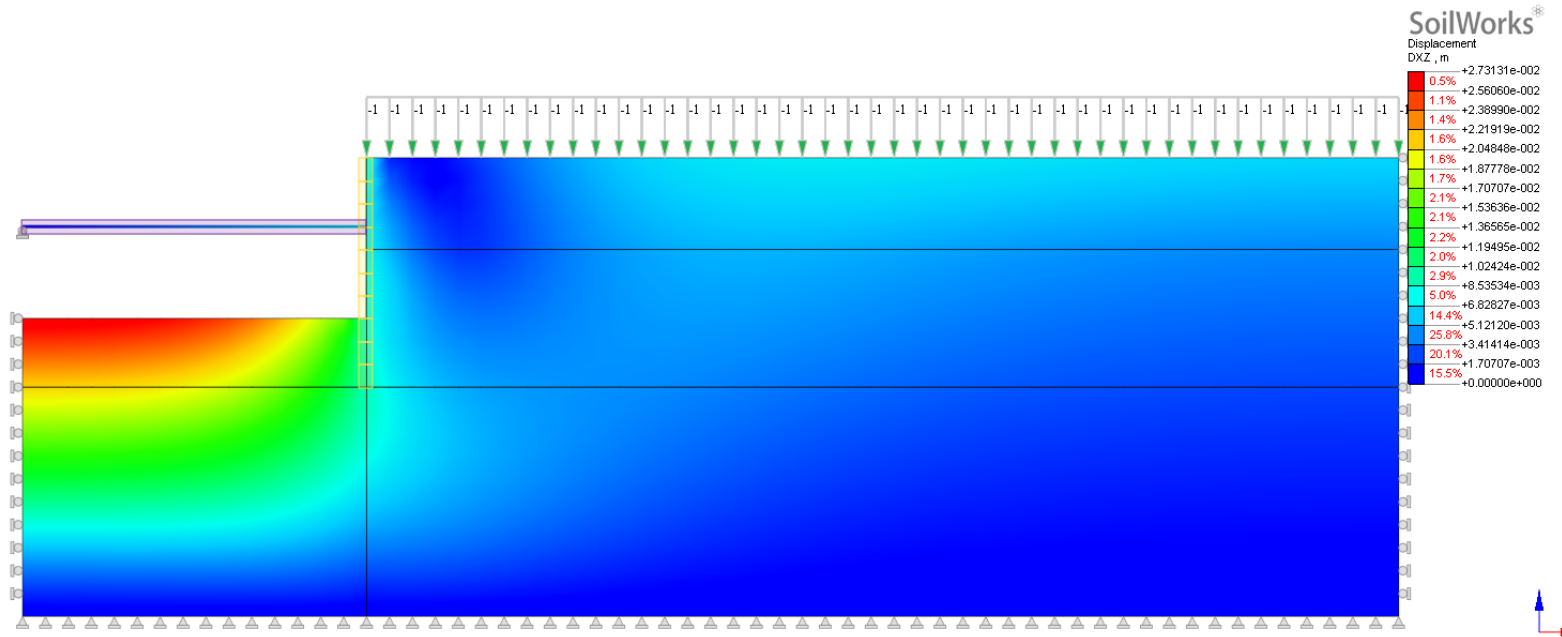

補充:分析文件

Soilworks_標準教學系列1_大地分析_1_設定檔.stb

*.stb=>分析設定檔

Soilworks_標準教學系列1_大地分析_1_設定檔_STB_Excavation.OUT

- Soilworks_標準教學系列1_大地分析_1_設定檔_STB_Excavation_Stage3. 1st Excavation.GNP
- Soilworks_標準教學系列1_大地分析_1_設定檔_STB_Excavation_Stage0. Initial.GNP
- Soilworks_標準教學系列1_大地分析_1_設定檔_STB_Excavation_Stage1. Diaphragm Wall.GNP
- Soilworks_標準教學系列1_大地分析_1_設定檔_STB_Excavation_Stage2. Pressure Load.GNP
- Soilworks_標準教學系列1_大地分析_1_設定檔_STB_Excavation_Stage4. 2nd Excavation.GNP

*.GNP=>分析結果檔

*.OUT=>計算迭代過程說明文件

```
Soilworks_標準教學系列1_大地分析_1_設定檔_STB_Excavation_Stage3. 1st Excavation.GNP
STEP NO. : 1 ITERATION NO. : 4
ALLOWABLE DISPLACEMENT NORM : 0.10000E-02 CALCULATED NORM : 0.97916E-03
WRITING STAGE 4 RESULT
STAGE NO. 5 / 5
> SYMMETRIC MULTI-FRONTAL SOLVER
> SYMMETRIC MULTI-FRONTAL SOLVER
STEP NO. : 1 ITERATION NO. : 1
ALLOWABLE DISPLACEMENT NORM : 0.10000E-02 CALCULATED NORM : 0.14630E-01
> SYMMETRIC MULTI-FRONTAL SOLVER
STEP NO. : 1 ITERATION NO. : 2
ALLOWABLE DISPLACEMENT NORM : 0.10000E-02 CALCULATED NORM : 0.96007E-02
> SYMMETRIC MULTI-FRONTAL SOLVER
STEP NO. : 1 ITERATION NO. : 3
ALLOWABLE DISPLACEMENT NORM : 0.10000E-02 CALCULATED NORM : 0.34712E-02
> SYMMETRIC MULTI-FRONTAL SOLVER
STEP NO. : 1 ITERATION NO. : 4
ALLOWABLE DISPLACEMENT NORM : 0.10000E-02 CALCULATED NORM : 0.15242E-03
WRITING STAGE 5 RESULT

ANALYSIS TYPE : NONLINEAR_STATICSTAGE ID : 1
>> CALCULATE THE INITIAL STAGE STATE
ANALYSIS TYPE : NONLINEAR_STATICSTAGE ID : 2
STEP ID : 1 ITERATION NO. : 1 TOLERANCE : 0.0000E+00 CONVERGED
ANALYSIS TYPE : NONLINEAR_STATICSTAGE ID : 3
STEP ID : 1 ITERATION NO. : 2 TOLERANCE : 0.1008E-03 CONVERGED
ANALYSIS TYPE : NONLINEAR_STATICSTAGE ID : 4
STEP ID : 1 ITERATION NO. : 4 TOLERANCE : 0.9792E-03 CONVERGED
ANALYSIS TYPE : NONLINEAR_STATICSTAGE ID : 5
STEP ID : 1 ITERATION NO. : 4 TOLERANCE : 0.1524E-03 CONVERGED
-----
ANALYSIS IS FINISHED
TOTAL ELAPSED TIME IS 2.28 SECONDS
-----
```



Soilwoks_標準教學系列

深開挖支撐工程施工階段分析



分析說明-材料模型

施工前

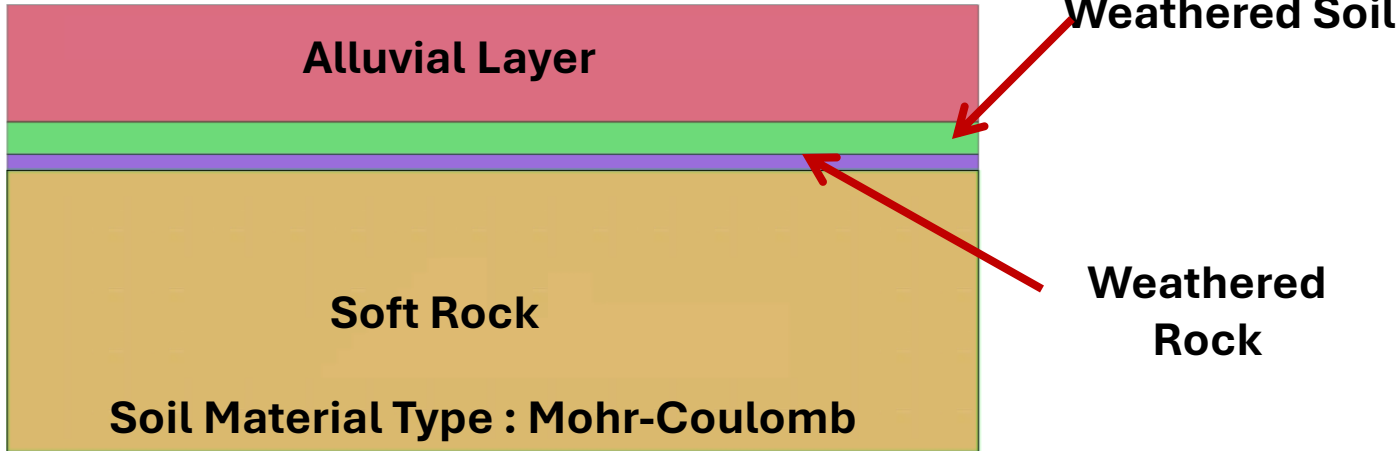

施工後

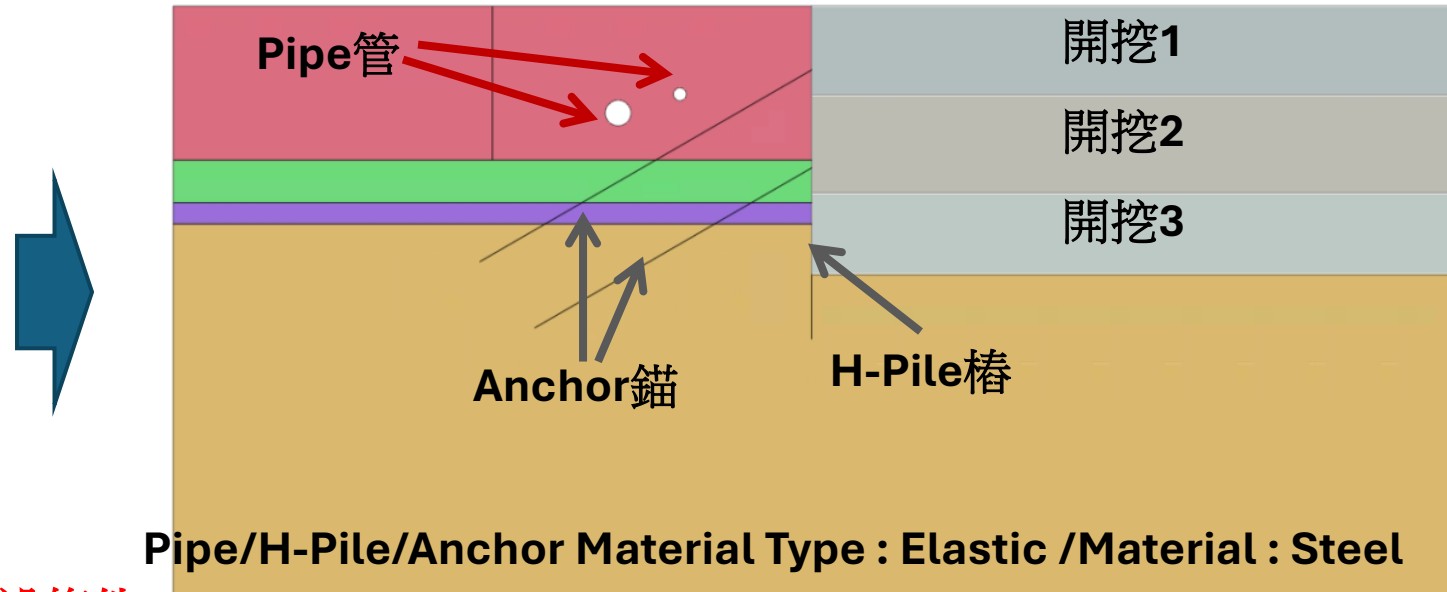

註:範例相關參數使用假設條件。



分析說明-施工流程

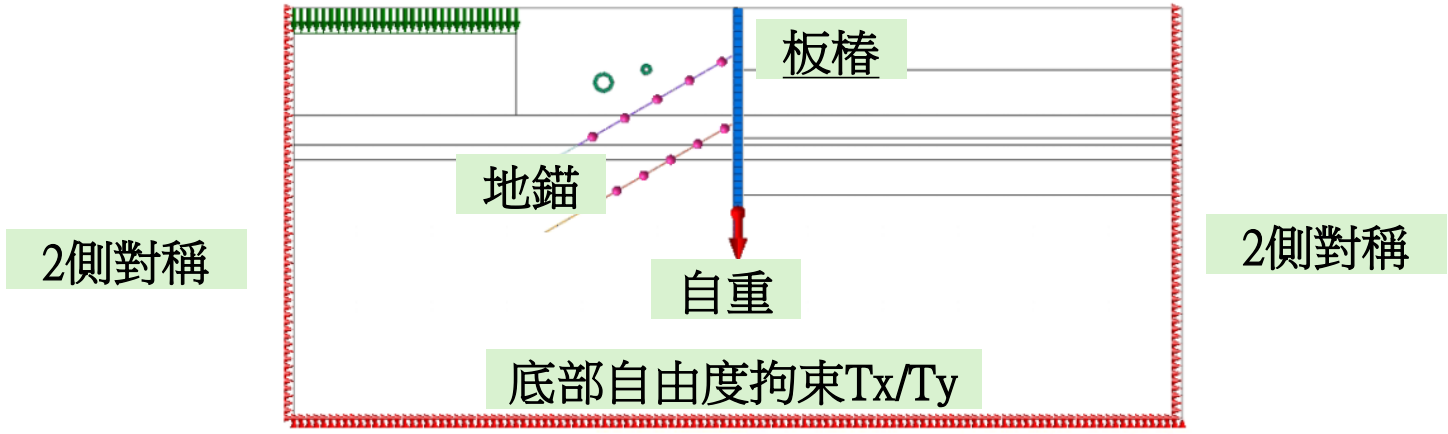

Stage1:Initial Stage

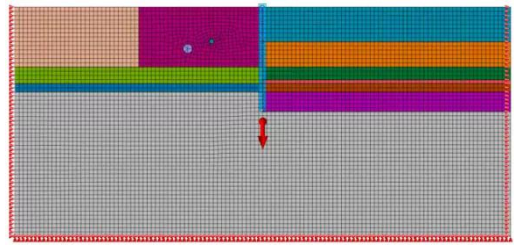

Stage2:管道

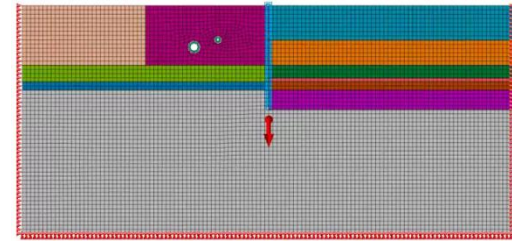

Stage3:連續壁&地表壓

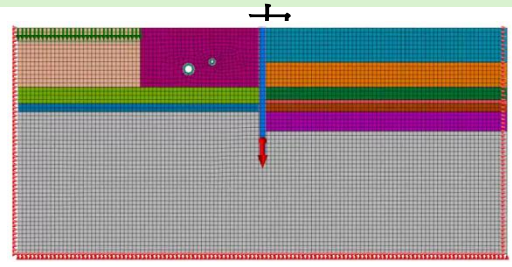

Stage4:開挖1和地錨1

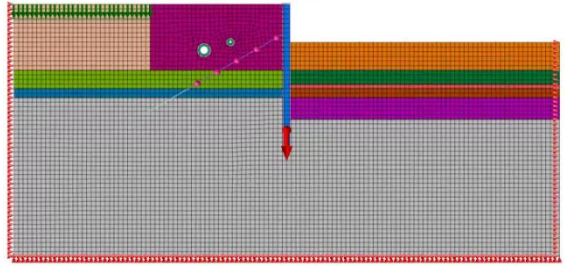

Stage5:開挖2和地錨2

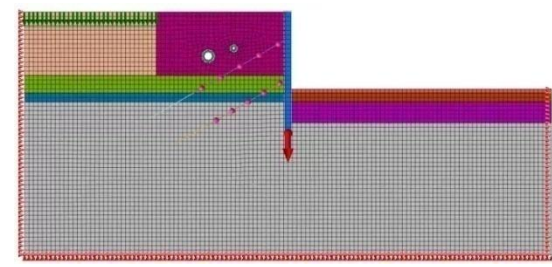

Stage6:開挖3

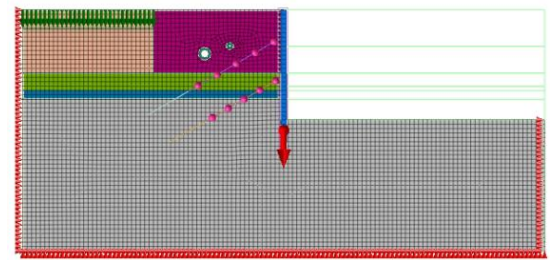

註:範例相關參數使用假設條件。

Agenda

- **Part1.開挖計算(未考慮界面元素)**
- **Part2.開挖計算+地錨(未考慮界面元素)**
- **Part3.界面元素**
- **Part4. 設計與報告**



Part1.開挖計算

(未考慮界面元素)



大地(Ground)模組



單位切換

The screenshot displays the MIDAS Gen software interface. The main workspace is dark and contains a blue text box with the text "使用者自訂使用單位" (User Customized Unit). Below this, two dialog boxes are open: "Define Initial Parameters" and "Unit Settings".

The "Define Initial Parameters" dialog box has the following settings:

Unit System	Force	Length	Time
SI	kN	m	sec
CGS			
FPS			
User Defined ...			

The "Unit Settings" dialog box has the following settings:

Force Unit [F]	Length Unit [L]	Time Unit [T]
<input type="radio"/> kgf	<input checked="" type="radio"/> m	<input checked="" type="radio"/> sec
<input type="radio"/> tonf	<input type="radio"/> cm	<input type="radio"/> min
<input type="radio"/> N	<input type="radio"/> mm	<input type="radio"/> hour
<input checked="" type="radio"/> kN	<input type="radio"/> ft	<input type="radio"/> day
<input type="radio"/> lbf	<input type="radio"/> inch	
<input type="radio"/> kips		

Below the dialog boxes, a blue text box with the text "單位使用KN/m/sec" (Unit Use KN/m/sec) is shown. A blue arrow points upwards from this box towards the "Unit Settings" dialog box.

The software interface includes a menu bar (Geometry, Model, Loads, Boundaries, Analysis | Design, Results, Tools, Window), a toolbar with various tools (Line, Arc, Circle, Point, Surface, Rectangle, Smart Surface, Copy, Move, Rotate, Mirror, Scale, Intersect, Extend, Trim, Offset, Array, Chamfer, Fillet, Remove, Reverse, Free Curve, Line Axis), and a left-hand tree view showing the project structure (Initial Variables, View Point, Layer Set, Mesh, Seed Data, Mesh Set, Property, Ground Material Property, Structural Property, Functions, Loads, Boundaries, Partial Factor, Construction Stage, Analysis Case).

DWG模型匯入

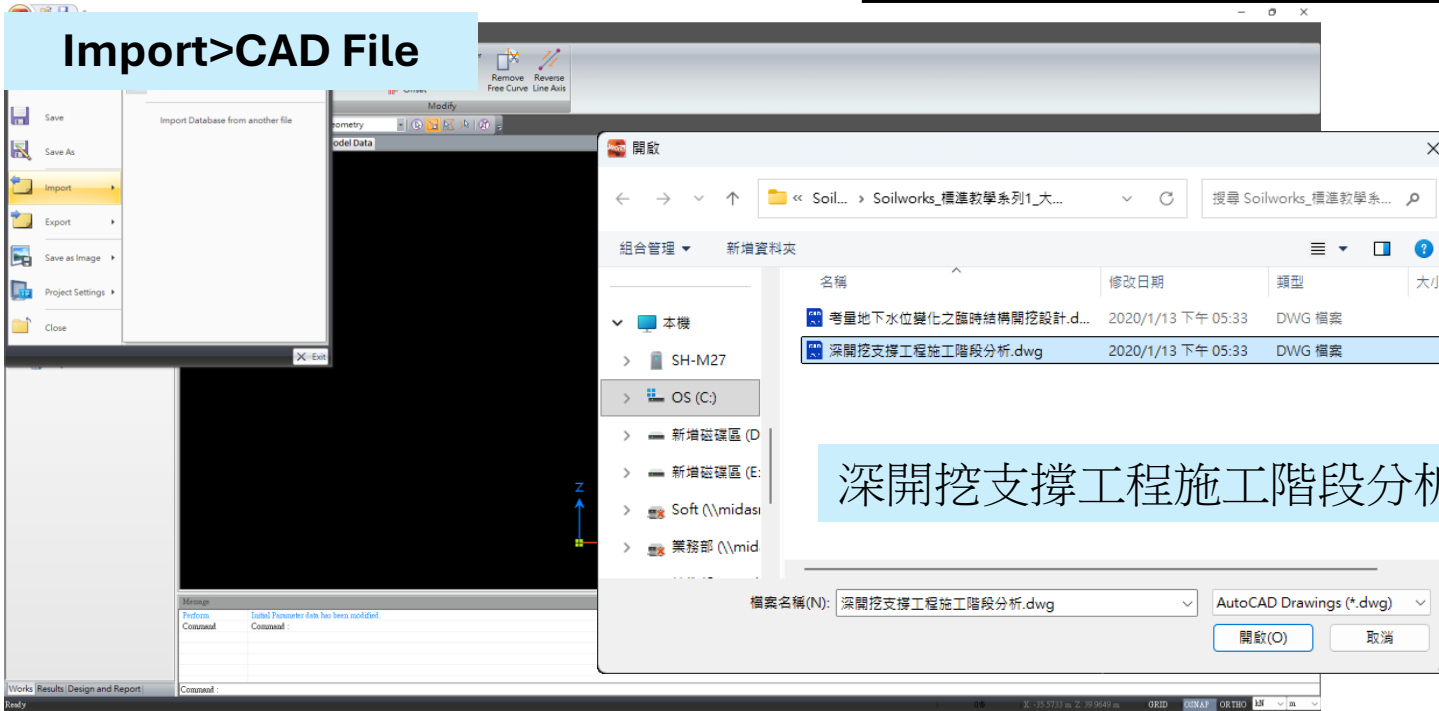

匯入後線特徵模型

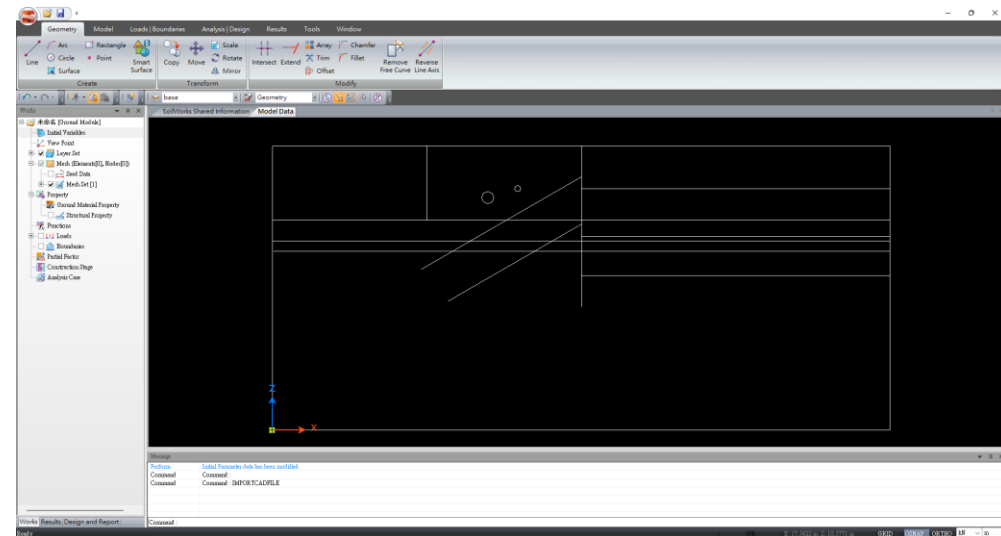
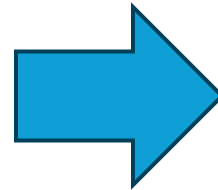

背景白色切換(補充)

Window選單>Display

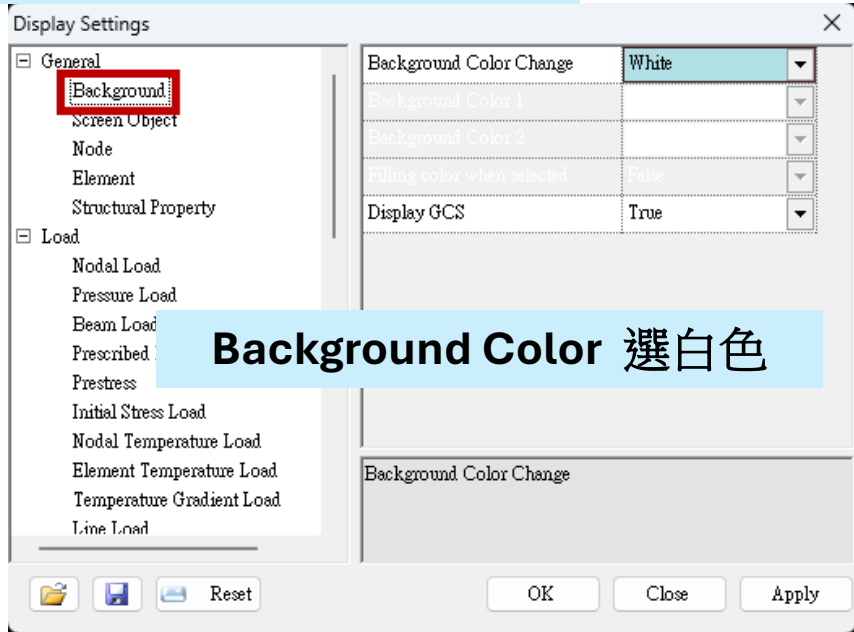

Screen Object
Change Background Color選Layer Color

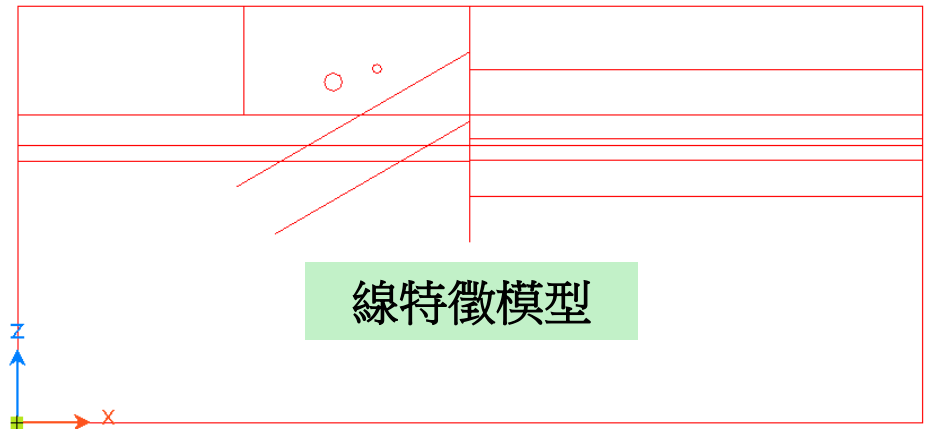
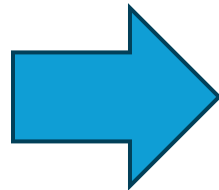
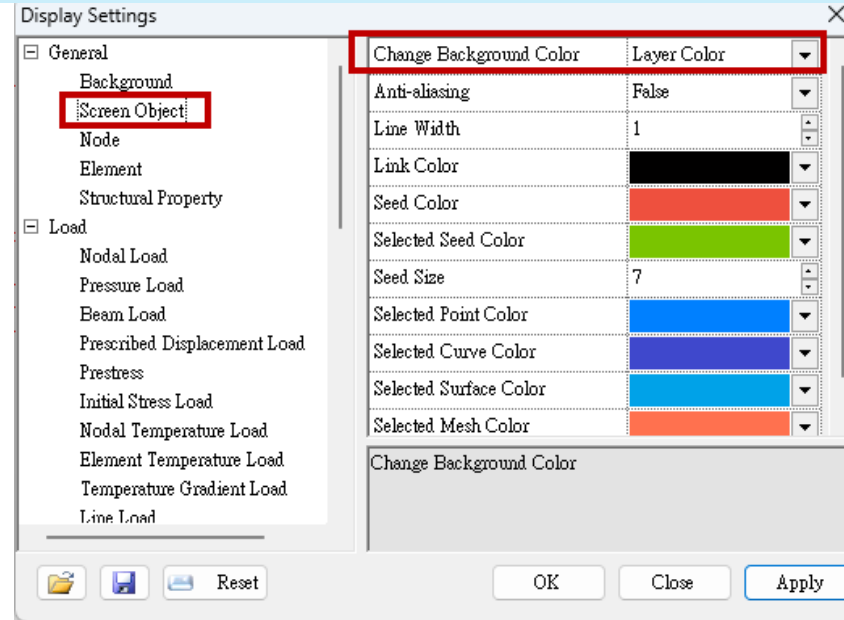

土壤材料屬性(手動)

Model選單>Property



補充:可以自訂顏色顯示

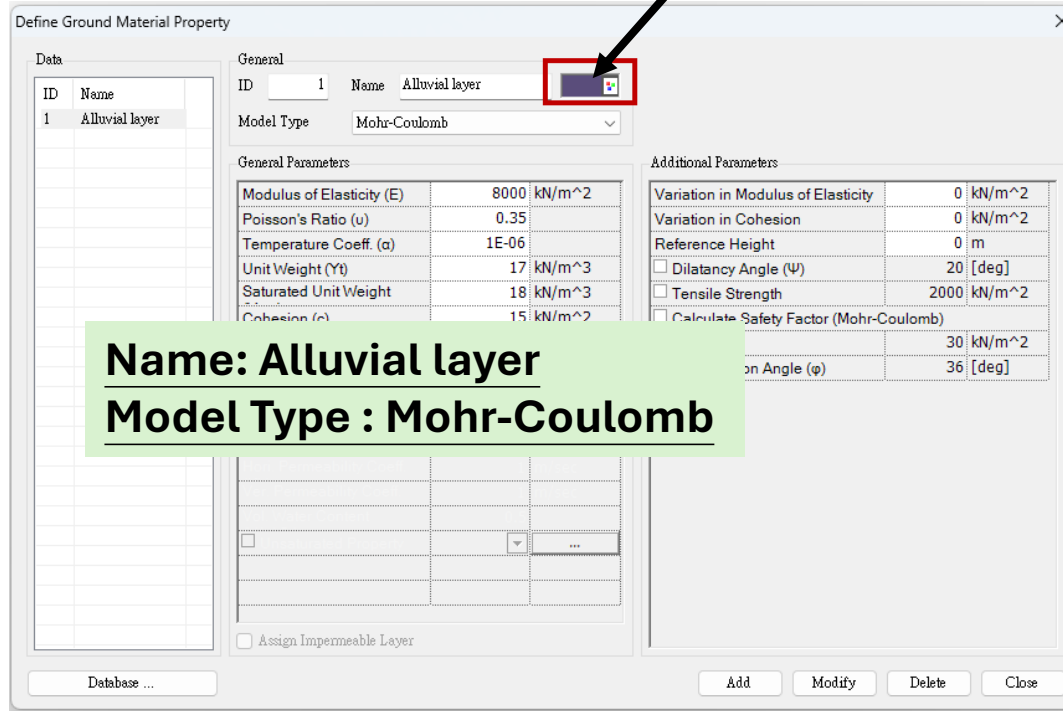

依序完成土壤材料新增



依照下表參數輸入

	Modulus of Elasticity(E) (KN/m ²)	Poisson's Ratio(v)	Unit Weight(γ) (KN/m ³)	Unit Weight(Saturated) (KN/m ³)	Cohesion(C) (KN/m ²)	Friction Angle(φ)	K0
Alluvial layer	8000	0.35	17	18	15	20	0.658
Weathered Soil	36500	0.33	18.5	19.5	17.5	31	0.485
Weathered rock	150000	0.3	21	22	50	33	0.455
Soft rock	18500000	0.28	24	25	180	35.5	0.419



土壤材料屬性(Soilworks材料庫)

Model選單>Property

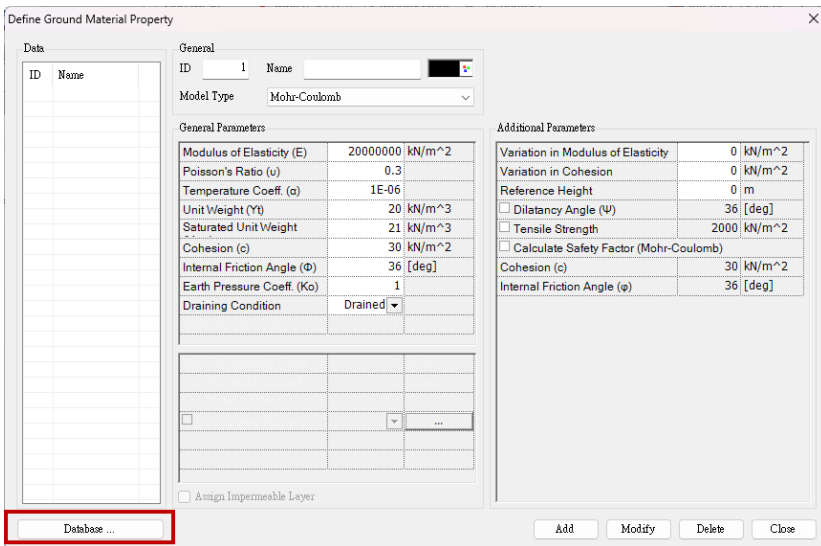

Soilworks材料庫

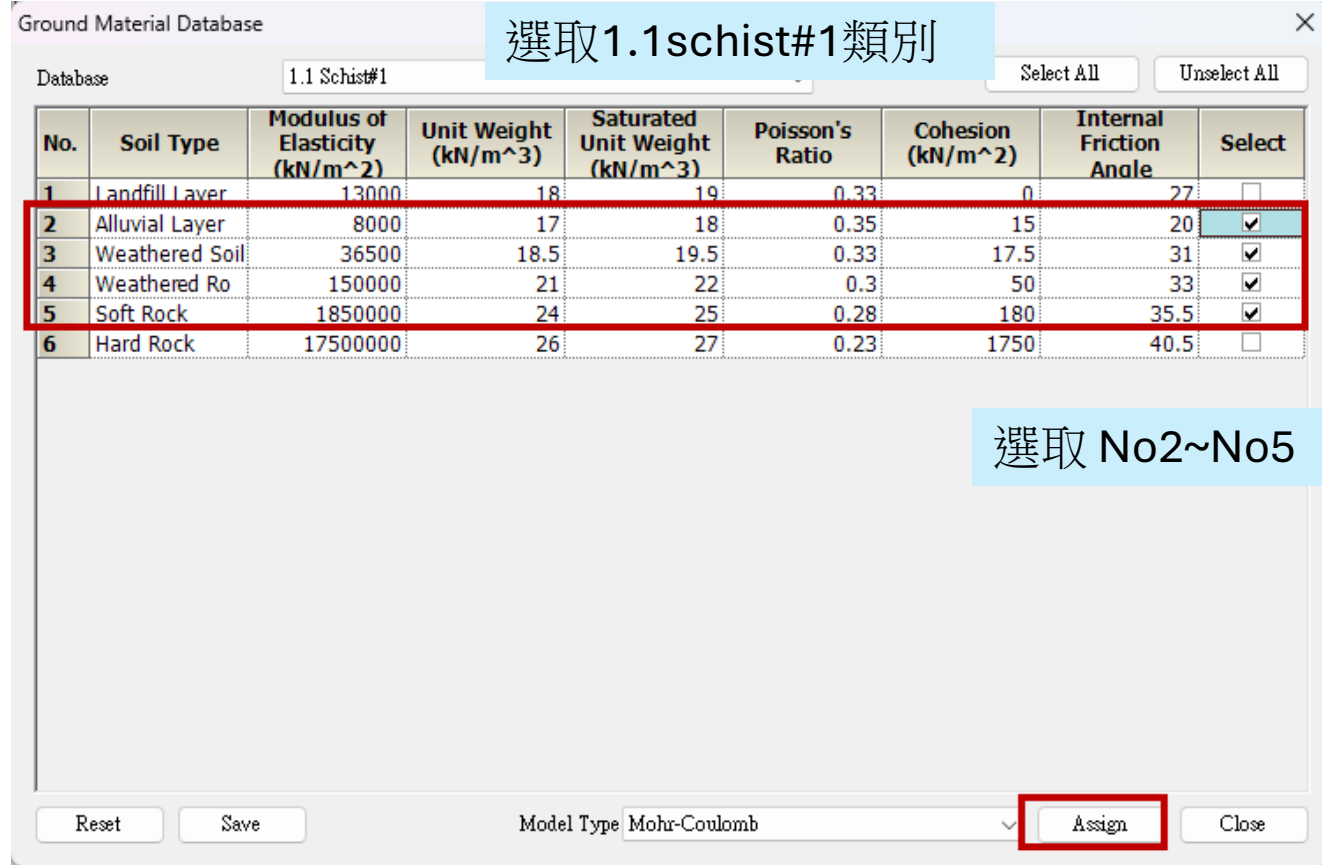

完成土壤材料新增



結構屬性-Pipe

Model選單>Property



General

ID 1 Name Pipe

Element Type Beam

Standard NONE

Horizontal Spacing 1.000 m

Section

Shape Rectangle Tapered Section

Sub-Shapes U Type

Section User Defined

Section-2 User Defined

Material

Material Type Steel

Concrete User Defined

SteelGrade User Defined

Section Data Material Data

Section Section-2 Stiffness

Section

H	0.03 m
B	1 m
Stiffness Calculation	
Area	0.03 m ²
Iy	0.000002 m ⁴
Zy	0.00015 m ³
Ry	0.00866 m

Section Data Material Data

Concrete Steel

Properties

Modulus of Elasticity	230000000 kN/m ²
Poisson's Ratio	0.3
Unit Weight	24 kN/m ³
Thermal Coefficient	0.000012
Design Strength	
Yield Strength	400000 kN/m ²

依照下表參數輸入

	Element Type	Horizontal Spacing (m)	Section(m)
Pipe	Beam	1	Rectangle (H:0.03 m, B: 1 m)

Modulus of Elasticity(E)(kN/m ²)	Poisson's Ratio(v)	Unit Weight(γ)(kN/m ³)
230,000,000	0.3	24



結構屬性-H-Pile

Model選單>Property



General

ID 2 Name H-Pile

Element Type Beam

Standard NONE

Horizontal Spacing 1.8 m

Section

Shape H Tapered Section

Sub-Shapes U Type

Section User Defined

Section-2 User Defined

Material

Material Type Steel

Concrete User Defined

SteelGrade User Defined

Section Data Material Data

Section Section-2 Stiffness

Section	
H	0.298 m
B1	0.201 m
tw	0.009 m
tf1	0.014 m
B2	0 m
tf2	0 m
Stiffness Calculation	
Area	0.008058 m ²
Iy	0.000128 m ⁴
Zy	0.000861 m ³
Ry	0.126201 m

Section Data Material Data

Concrete Steel

Properties

Modulus of Elasticity	210000000	kN/m ²
Poisson's Ratio	0.3	
Unit Weight	77	kN/m ³
Thermal Coefficient	0.000012	
Design Strength		
Yield Strength	240000	kN/m ²

依照下表參數輸入

	Element Type	Horizontal Spacing (m)	Section(m)
H-Pile	Beam	1.8	H (0.298×0.201×0.009/0.014)

Modulus of Elasticity(E)(kN/m ²)	Poisson's Ratio(v)	Unit Weight(γ)(kN/m ³)	Yield Strength(kN/m ²)
210,000,000	0.3	77	240,000



結構屬性-Anchor

Model選單>Property



General

ID 3 Name Anchor

Element Type **Embedded Truss**

Standard NONE

Horizontal Spacing 2.7 m

Section

Shape Strand Tapered Section

Sub-Shapes U Type

Section User Defined

Section-2 User Defined

Material

Material Type Strand

Concrete User Defined

Strand Grade User Defined

Section Data Material Data

Section Section-2 Stiffness

Stiffness

Area 0.000395 m²

Section Data Material Data

Concrete Steel Wire

Properties

Modulus of Elasticity	200000000	kN/m ²
Poisson's Ratio	0.3	
Unit Weight	77	kN/m ³
Thermal Coefficient	0.000012	
Design Strength		
Yield Strength	1570000	kN/m ²

依照下表參數輸入

	Element Type	Horizontal Spacing (m)	Area(m ²)
Anchor	Embedded Truss	2.7	0.00039484

Modulus of Elasticity(E)(kN/m ²)	Poisson's Ratio(v)	Unit Weight(γ)(kN/m ³)	Yield Strength(kN/m ²)
200,000,000	0.3	77	1,570,000



面特徵編輯建立(補充)

Geometry 選單>Smart Surface

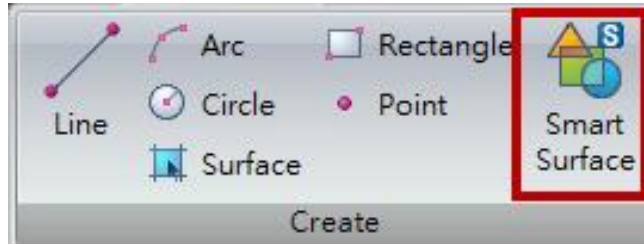

Undo

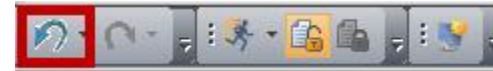

自動生成面特徵

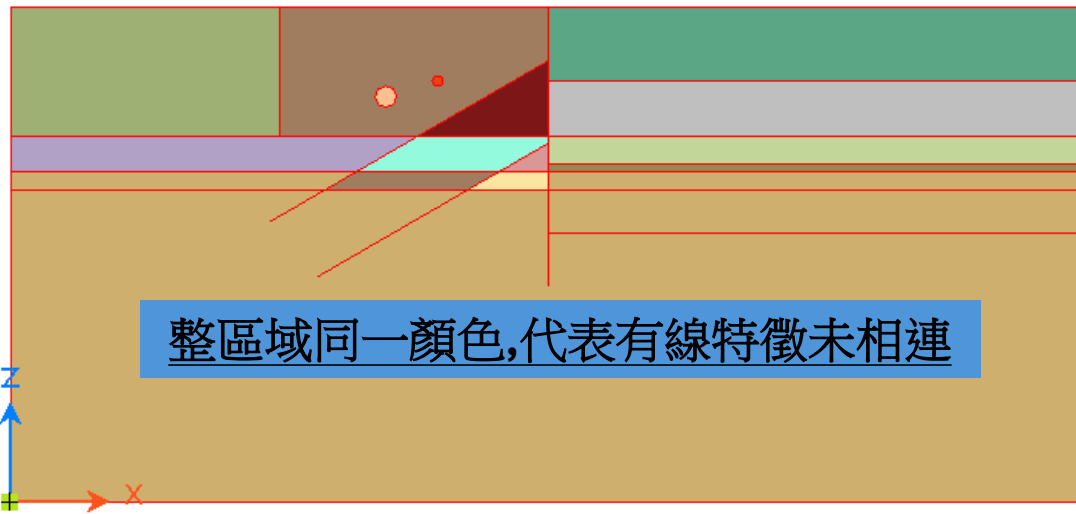

線特徵未相連&未相交

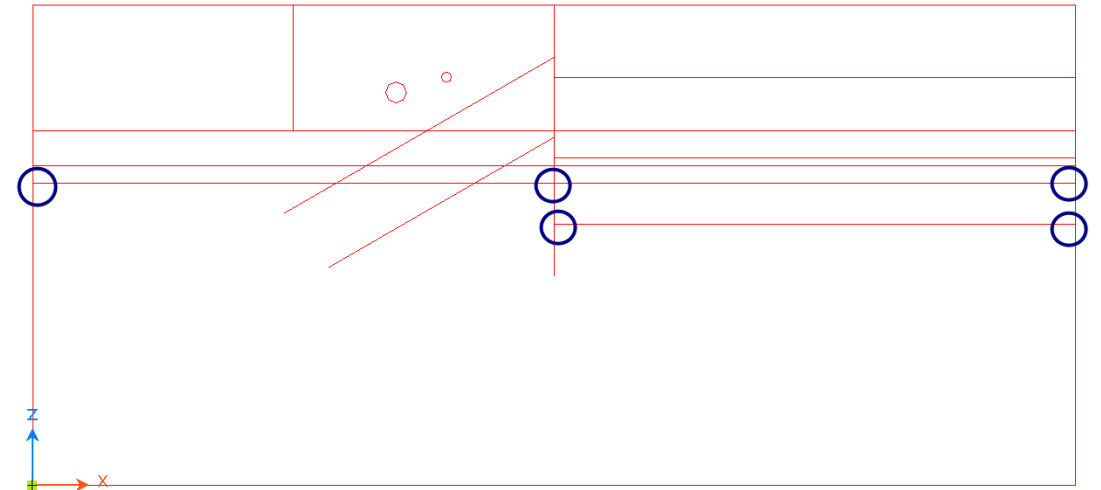

Layer Color(顏色顯示方式)



面特徵編輯建立-1

Geometry 選單>Modify

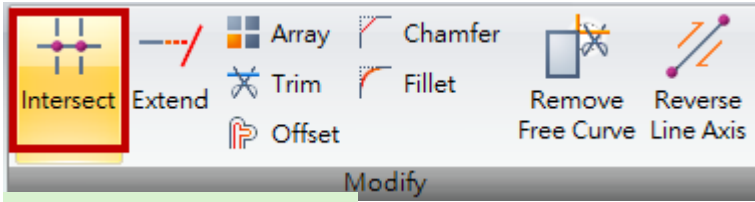

點選Intersect

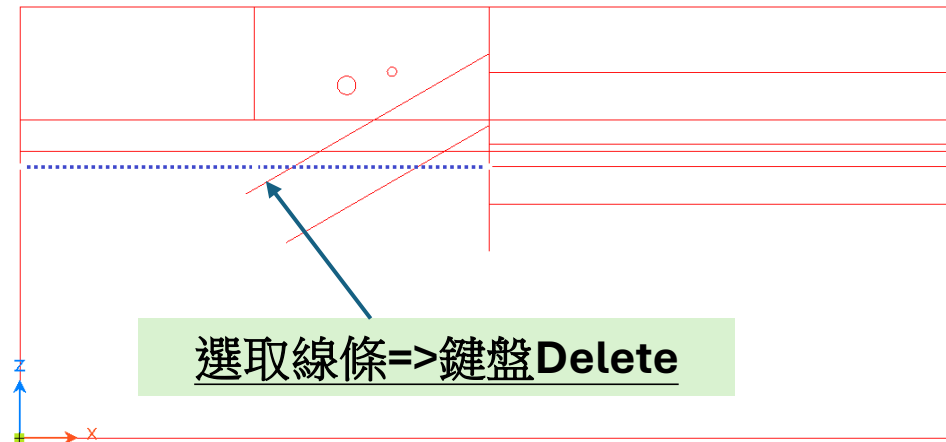
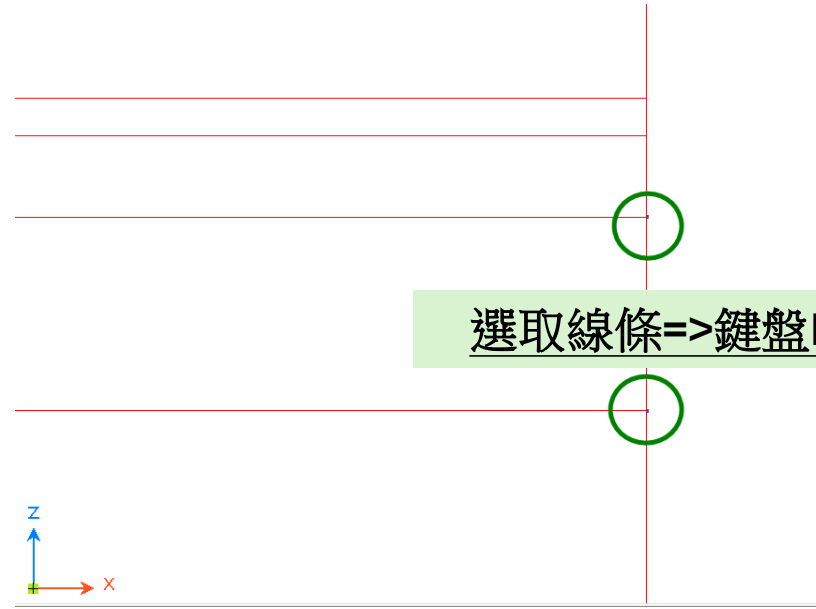
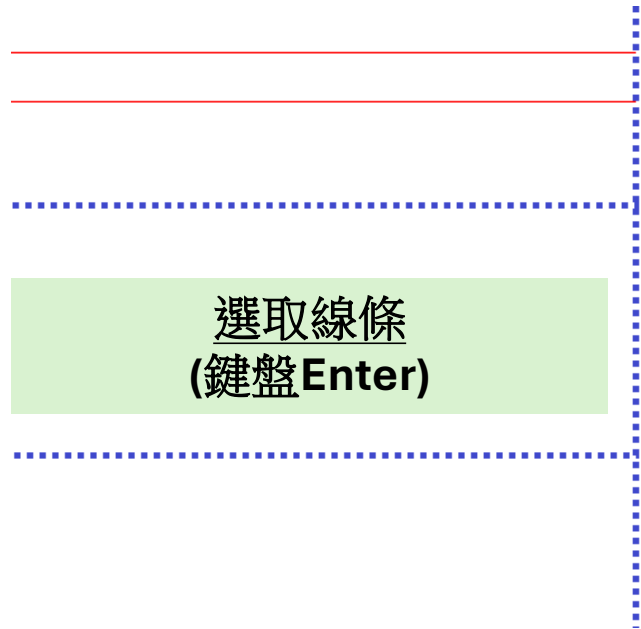

面特徵編輯建立-3

Geometry 選單>Modify

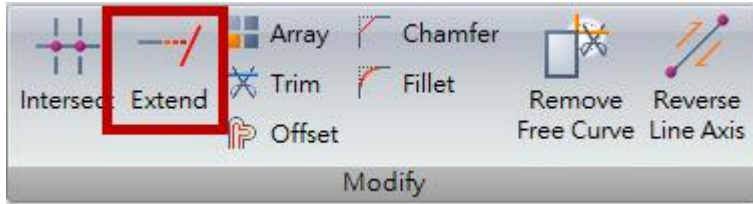

點選Extend

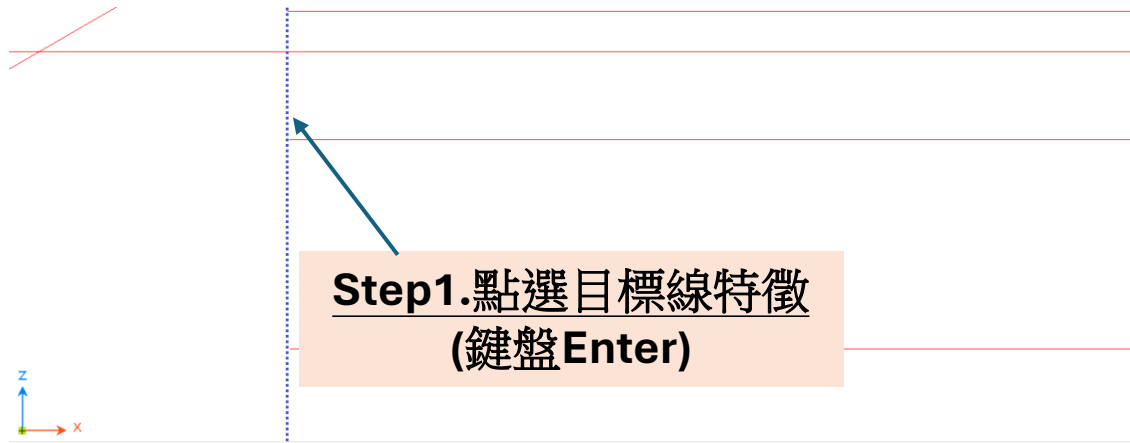

Message	
Command	Select objects to extend:EXTEND
Command	Command : EXTEND
Command	Select boundary objects:
Command	Select objects = 1 found, 1 total
Command	Select boundary objects:

Step2.點選要延伸線特徵

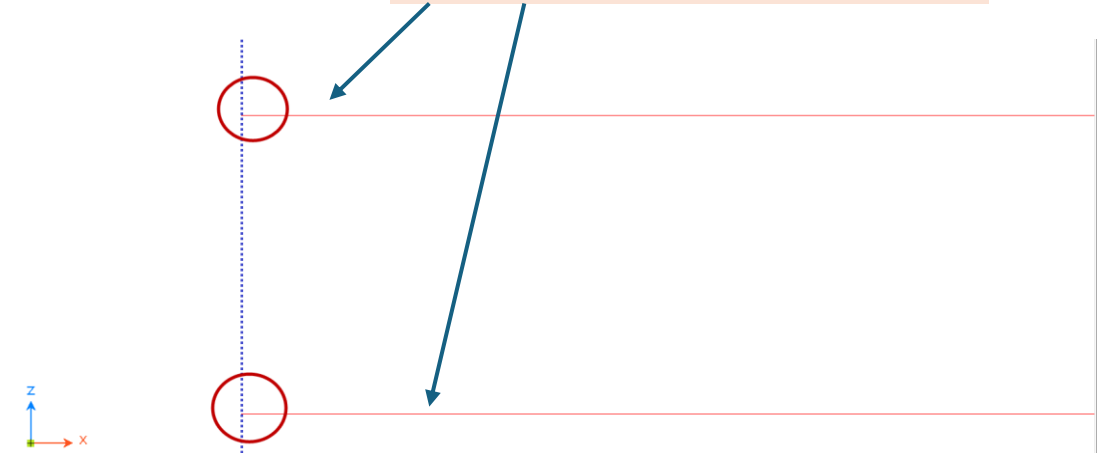

面特徵編輯建立-4

Object Snap物件鎖點方式定義
(滑鼠右鍵)

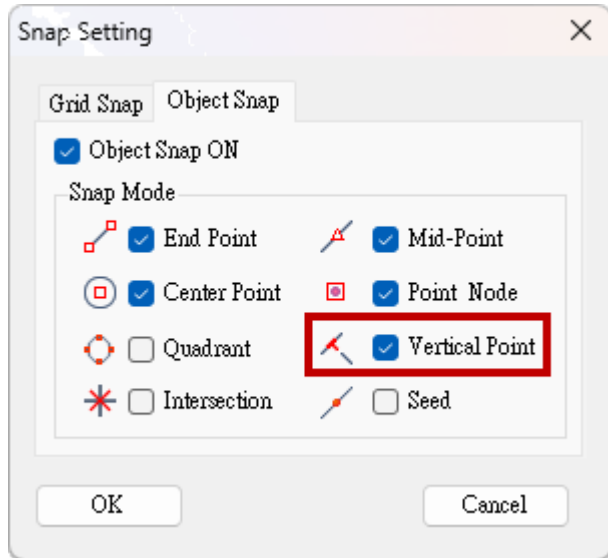

開啓Vertical Point

Geometry 選單>Create

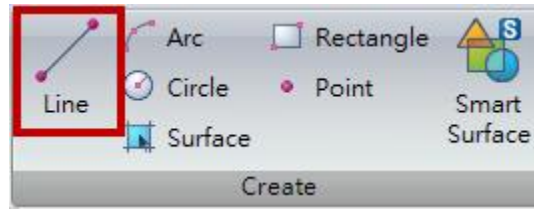

點選Line

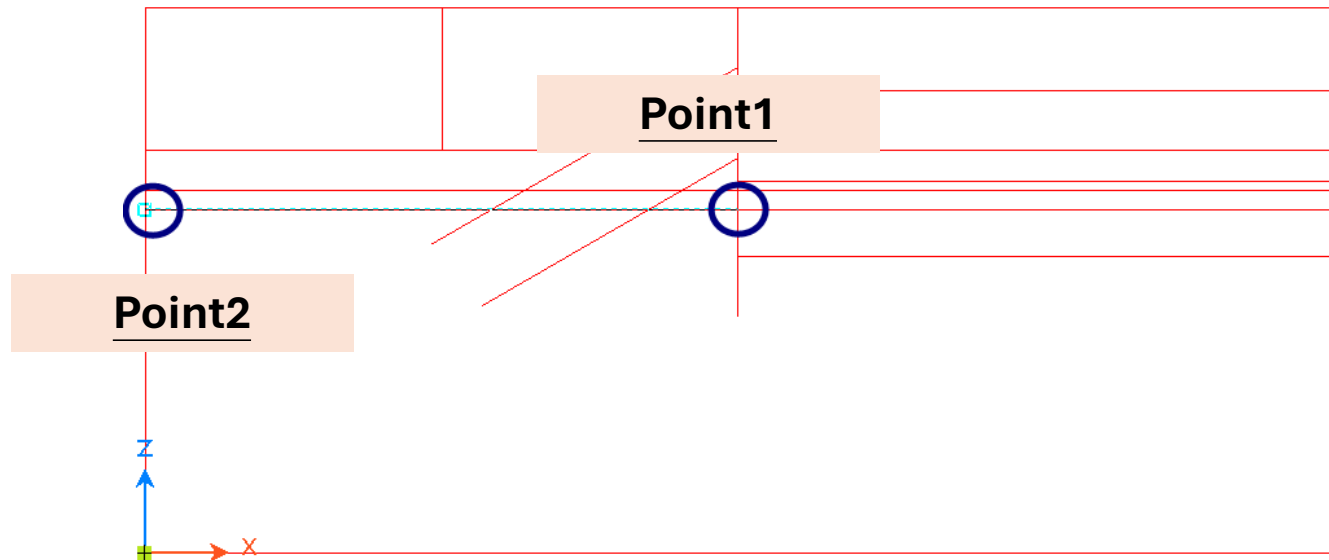

面特徵編輯建立-5

Geometry 選單>Modify

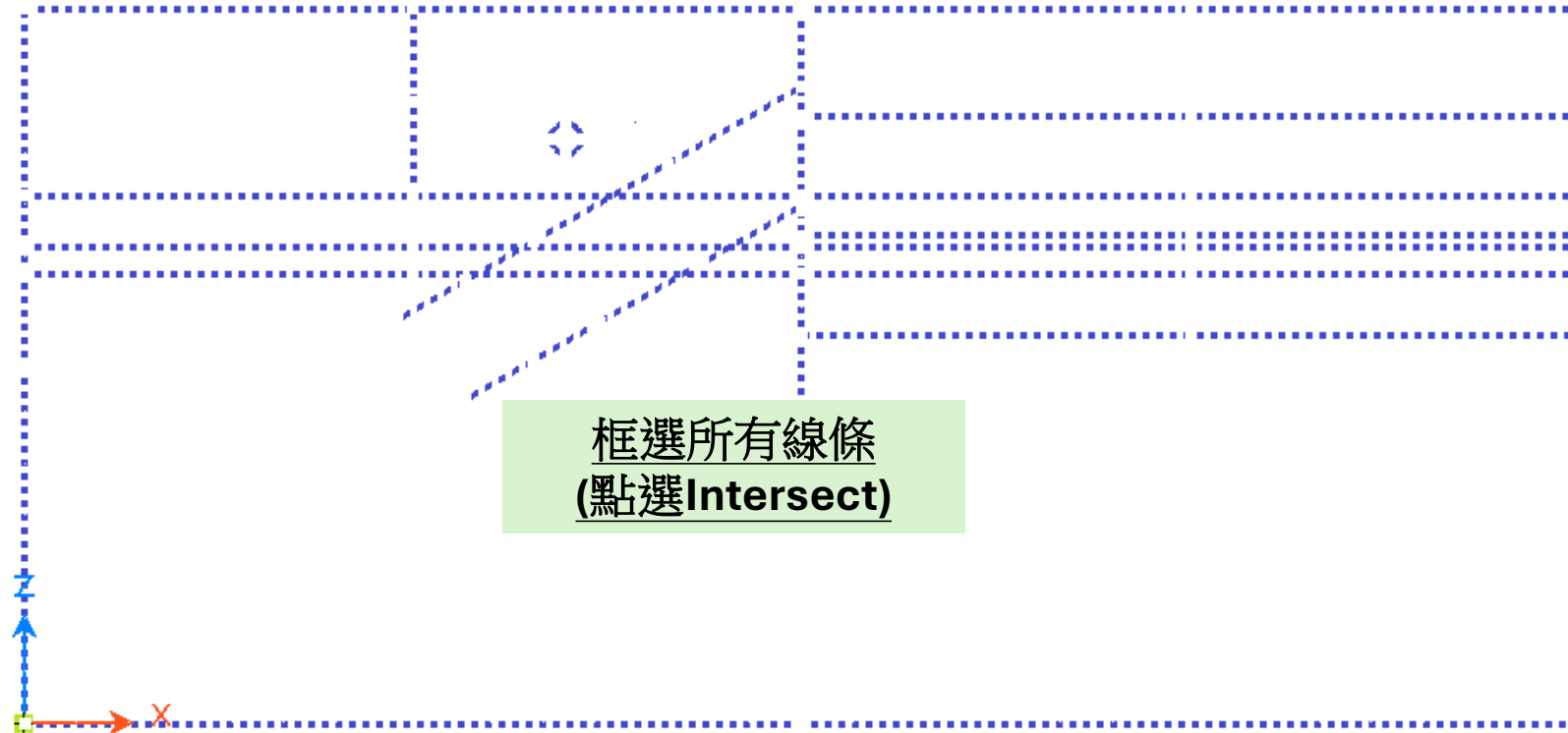
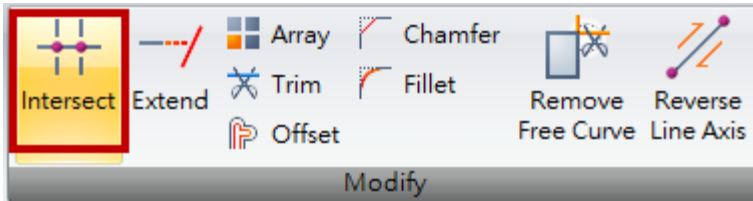

框選所有線條
(點選Intersect)

面特徵編輯建立-6

Geometry 選單>Smart Surface

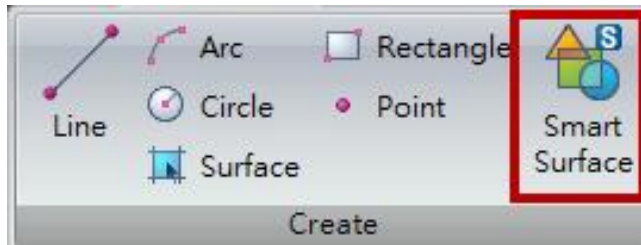

自動生成面特徵

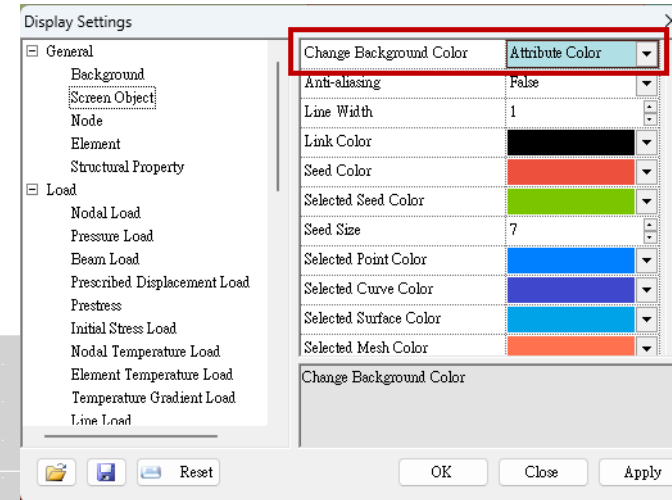
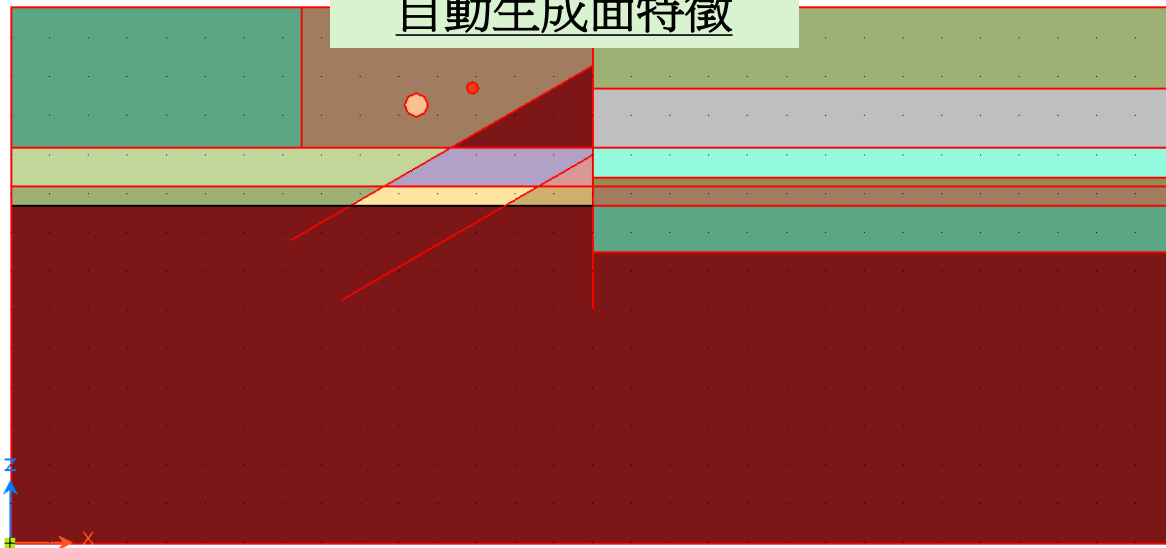

Attribute Color(顏色顯示方式)

土壤材料屬性指定-1

Select Filter 切換到 Surface

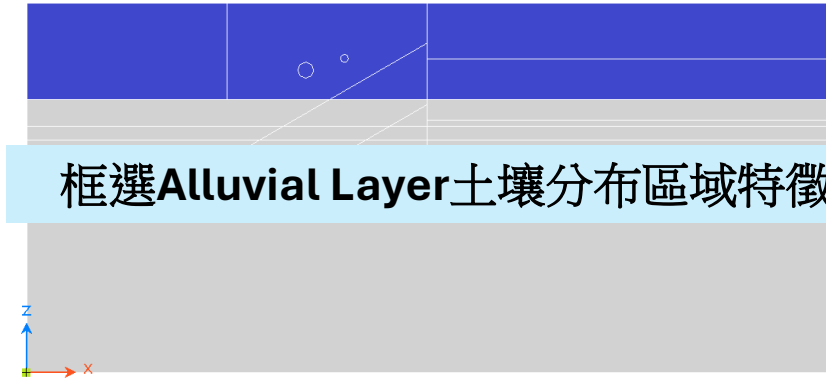
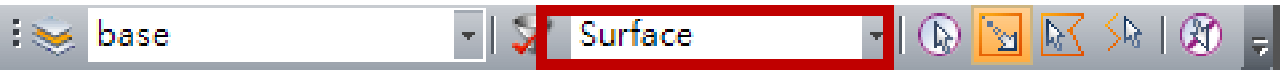

框選 Alluvial Layer 土壤分布區域特徵

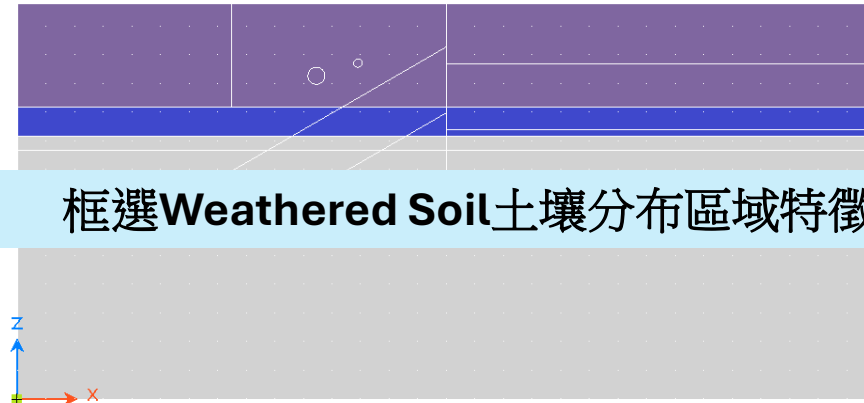

框選 Weathered Soil 土壤分布區域特徵

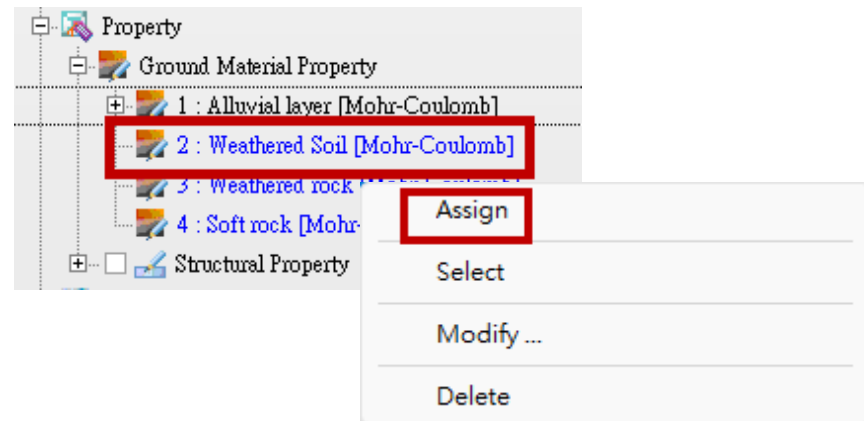
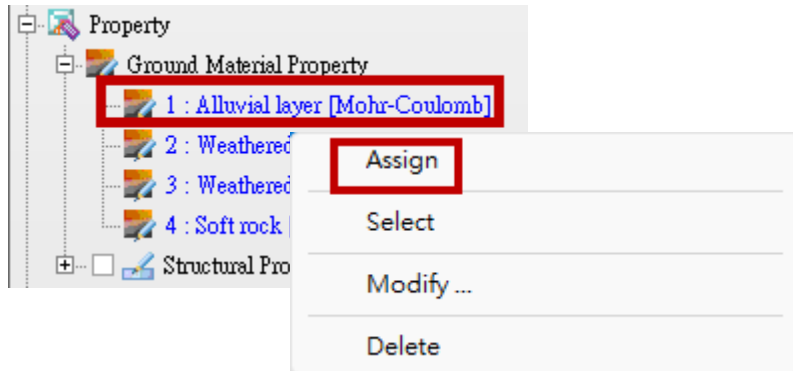

土壤材料屬性指定-2

Select Filter 切換到 Surface

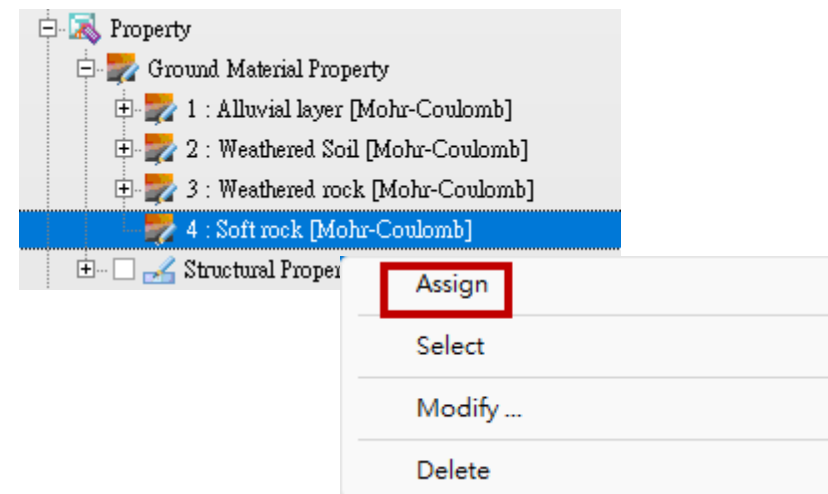
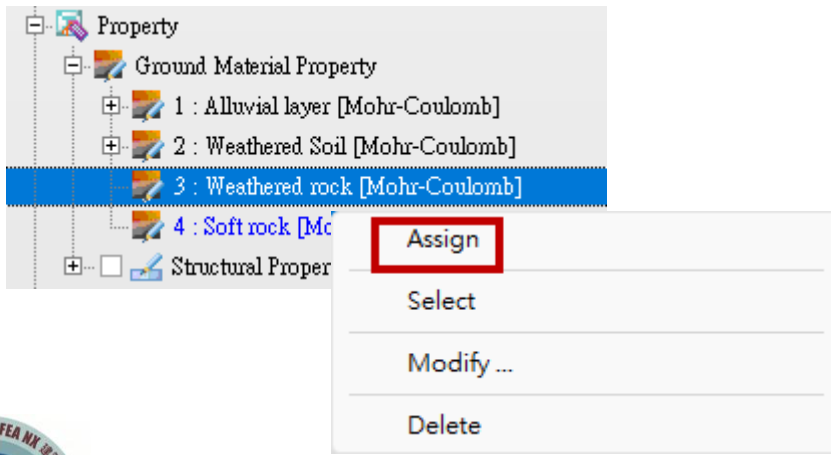
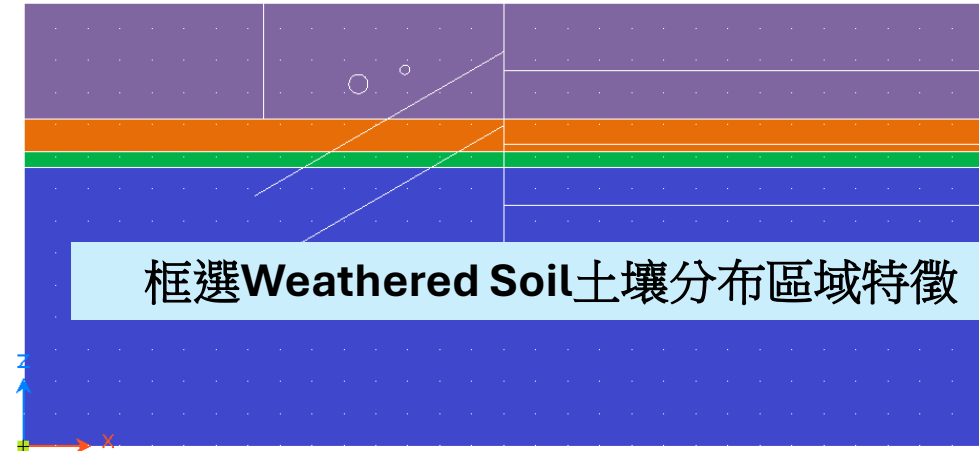
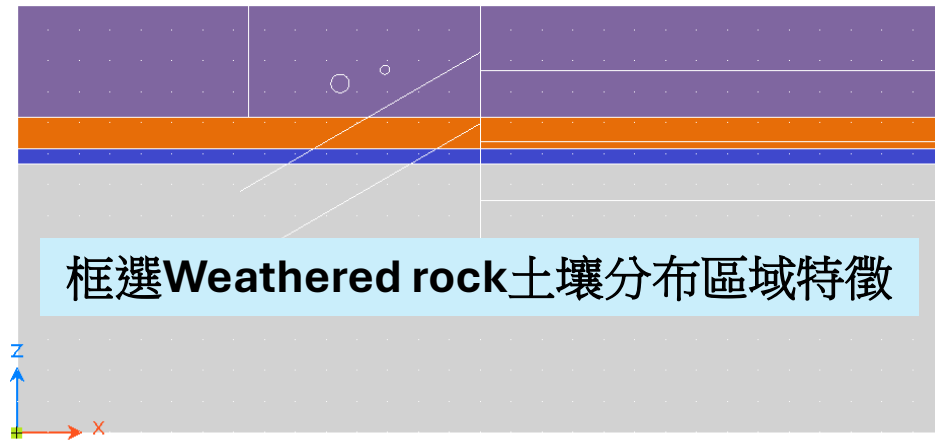
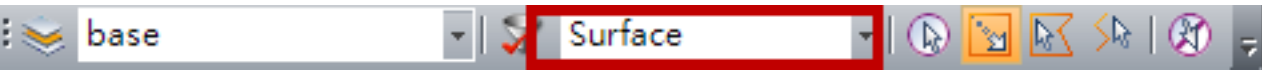

結構屬性指定- Pipe

Select Filter 切換到 Curve

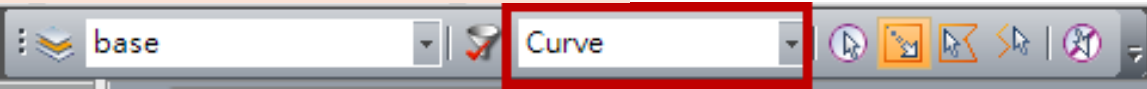

Pipe

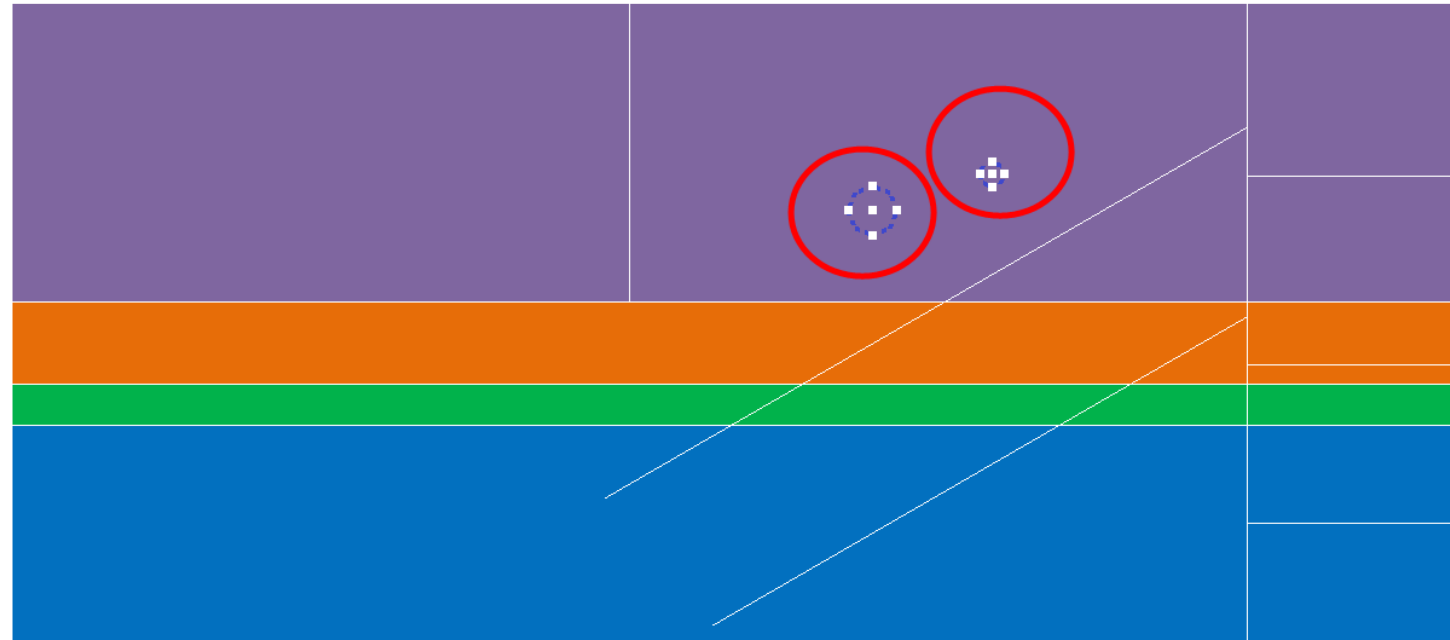
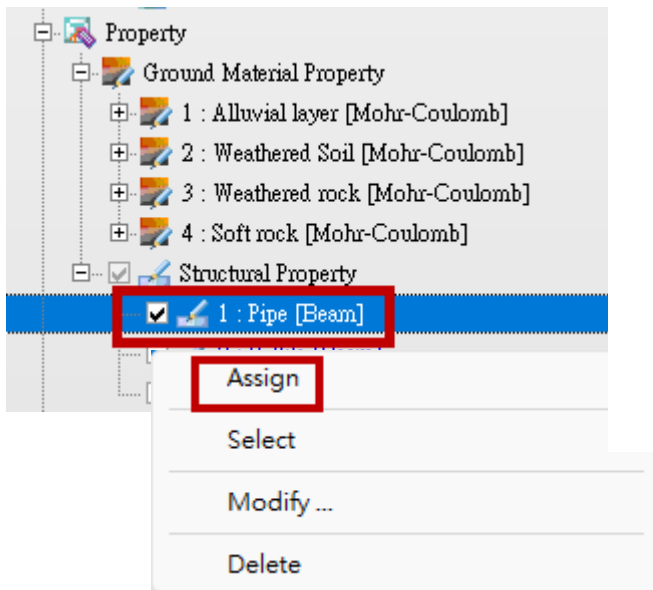

結構屬性指定- H-Pile

Select Filter 切換到 Curve

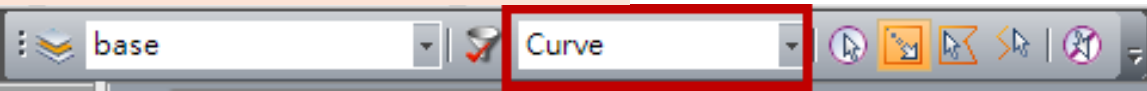

H-Pile

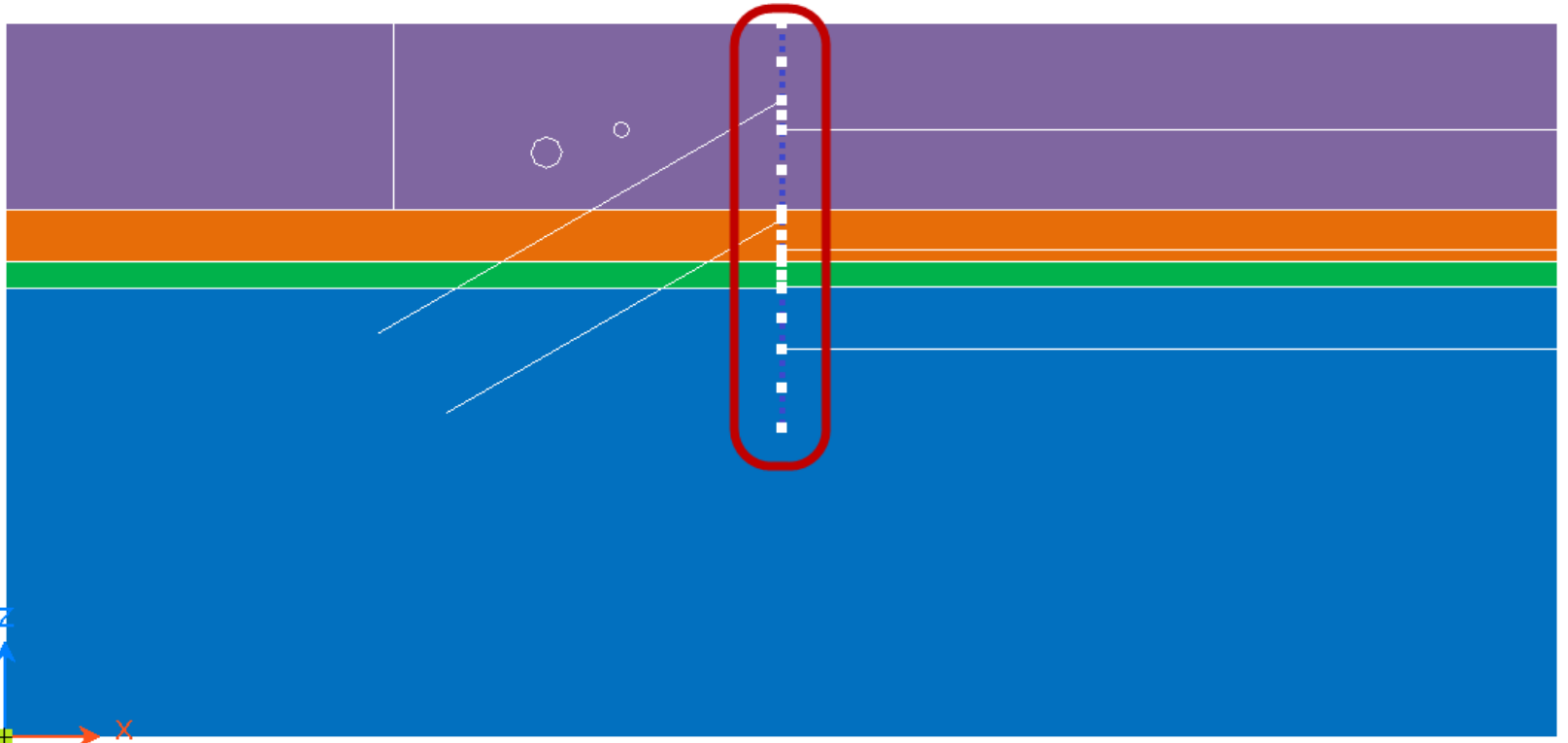
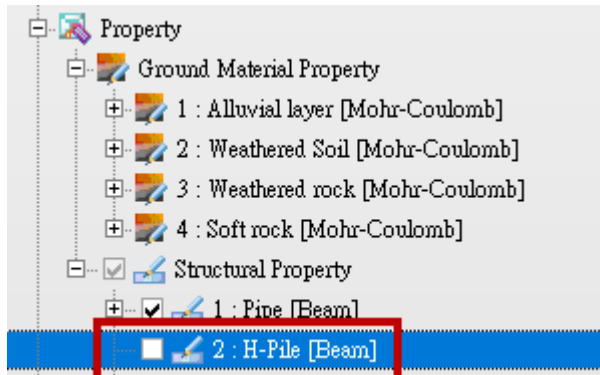

Model選單> Mesh

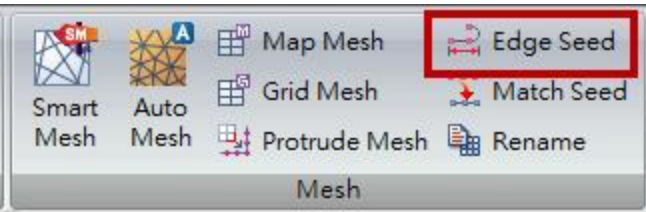

指定網格尺寸-1

Select Filter 切換到 Curve

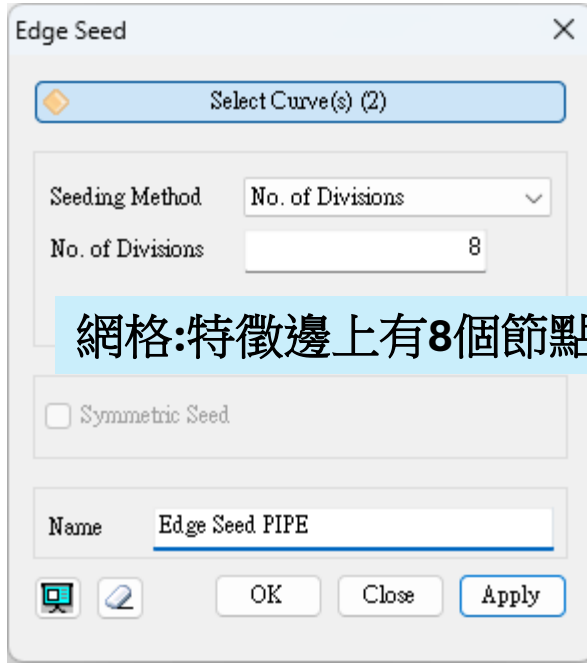
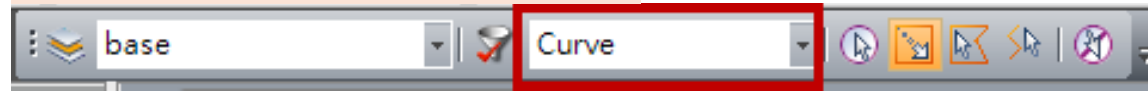

框選PIPE線特徵



Model選單> Mesh

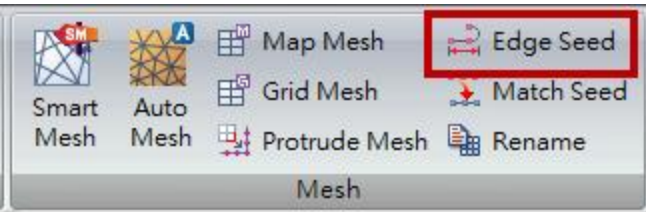

指定網格尺寸-2

Select Filter 切換到 Curve

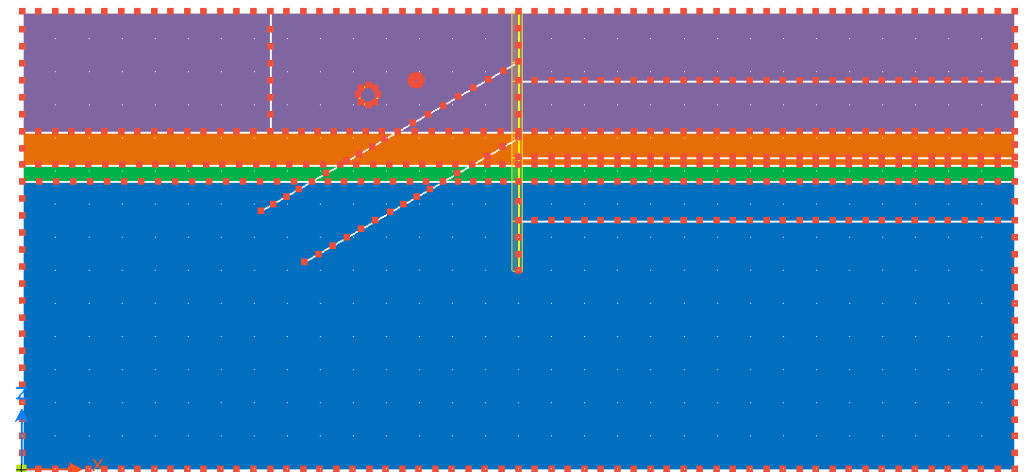
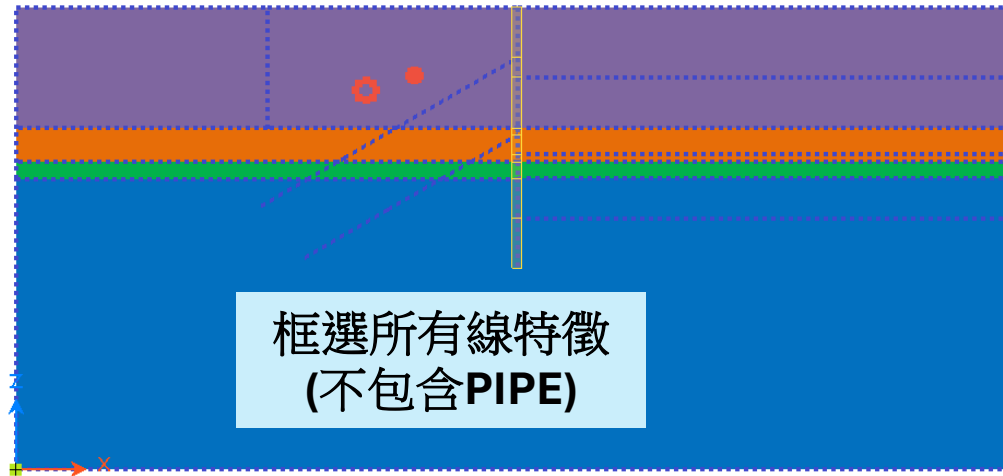
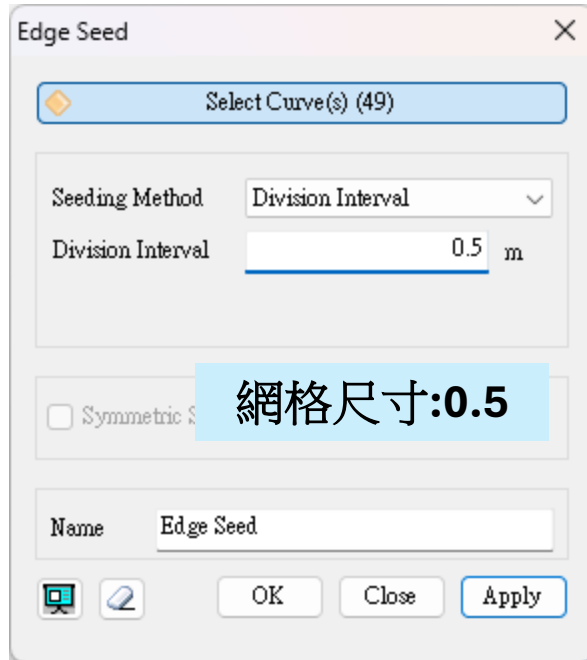
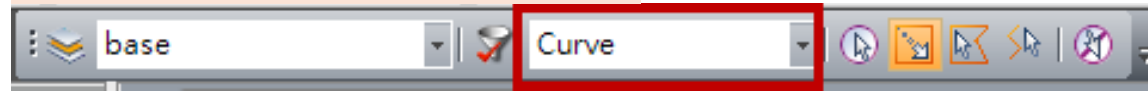

Model選單> Mesh



2D網格生成 (自動)

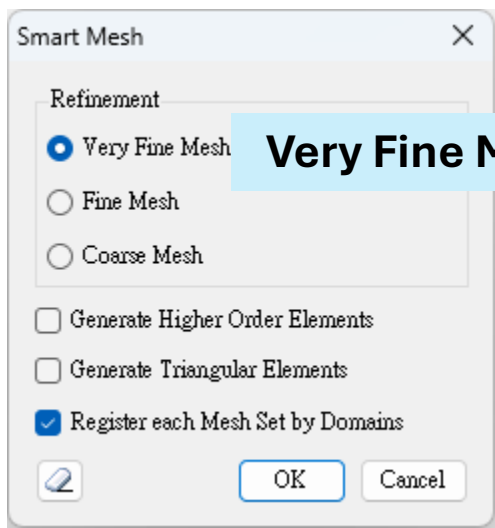

Very Fine Mesh

每個面特徵各別生成網格集

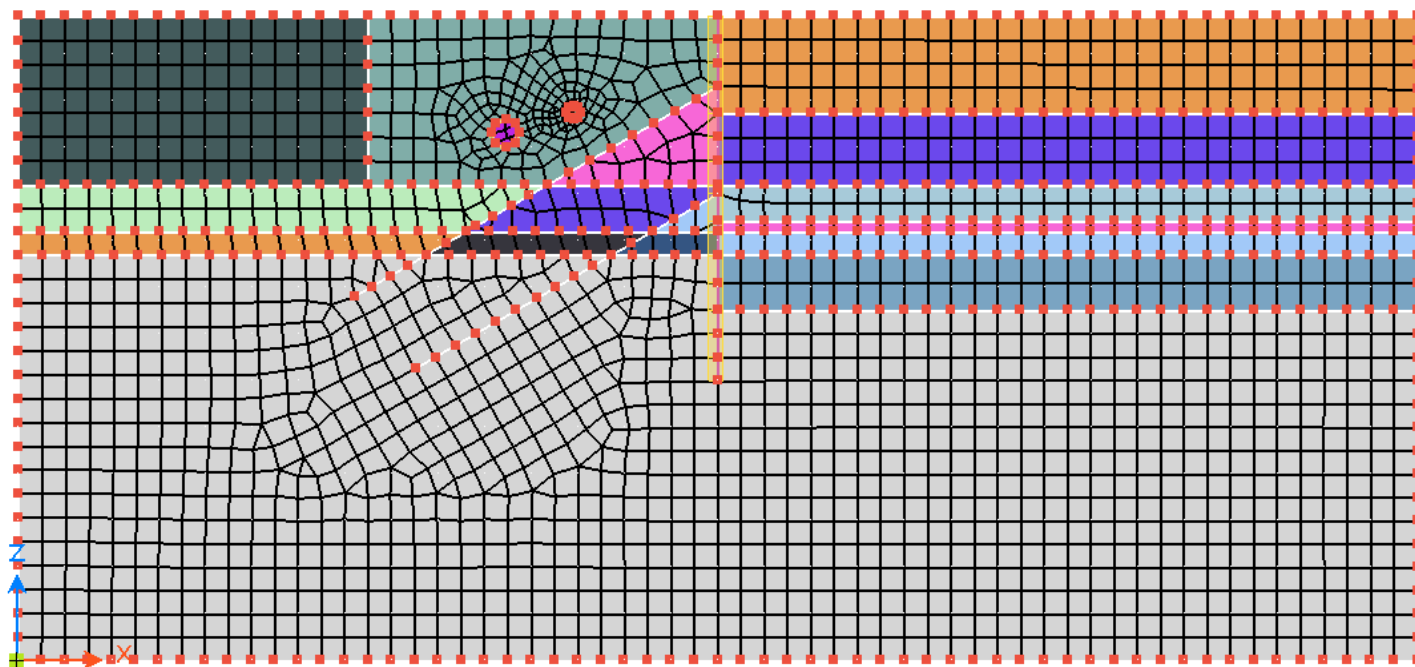

網格集名稱編輯

Select Filter 切換到 Mesh



點選網格集,按F2可以編輯名稱

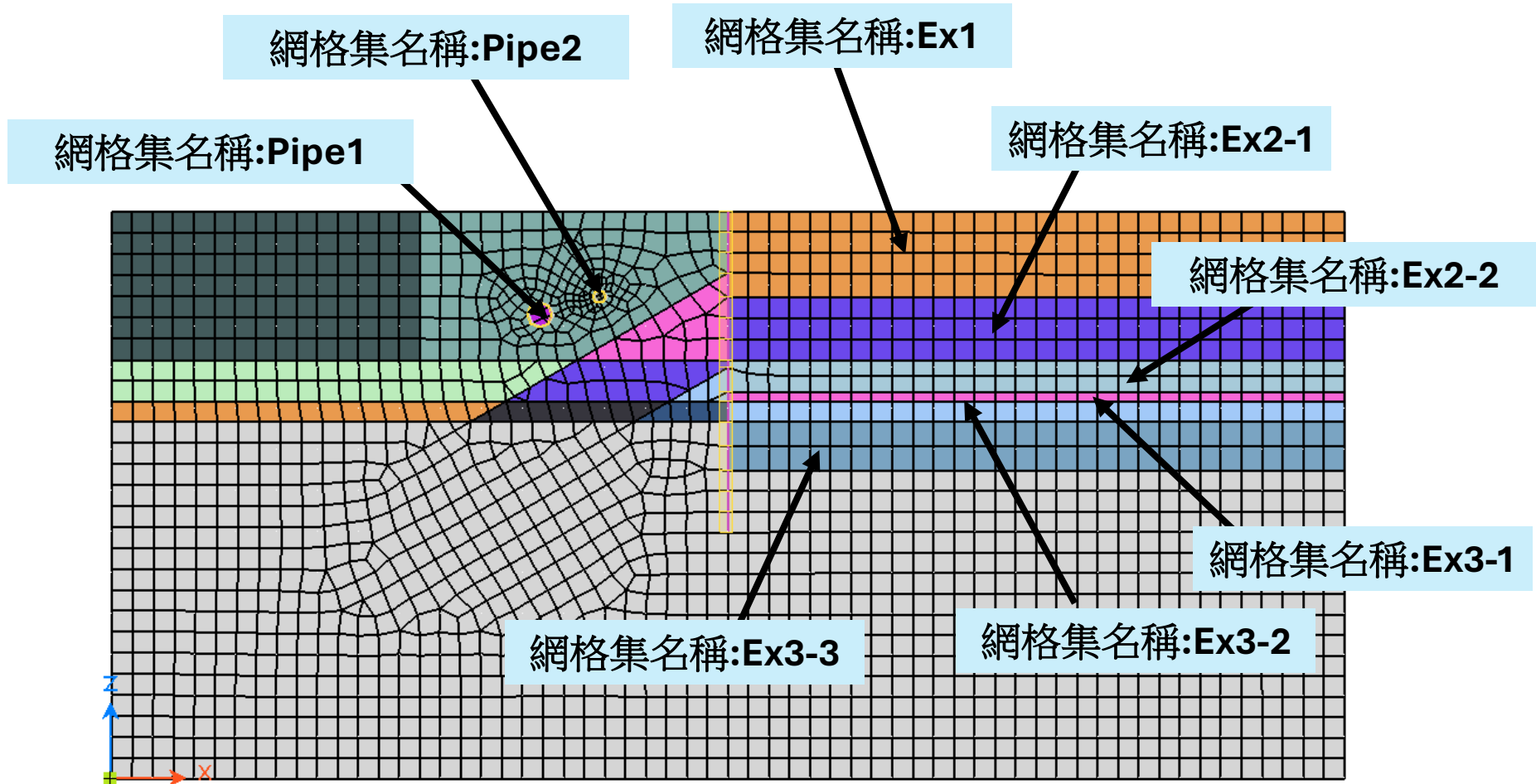

壓力施加

Loads | Boundaries 選單



Select Filter 切換到 Element Boundary Curve

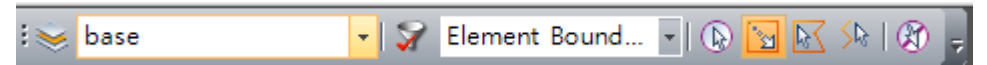

載荷集名稱: Pressure Load

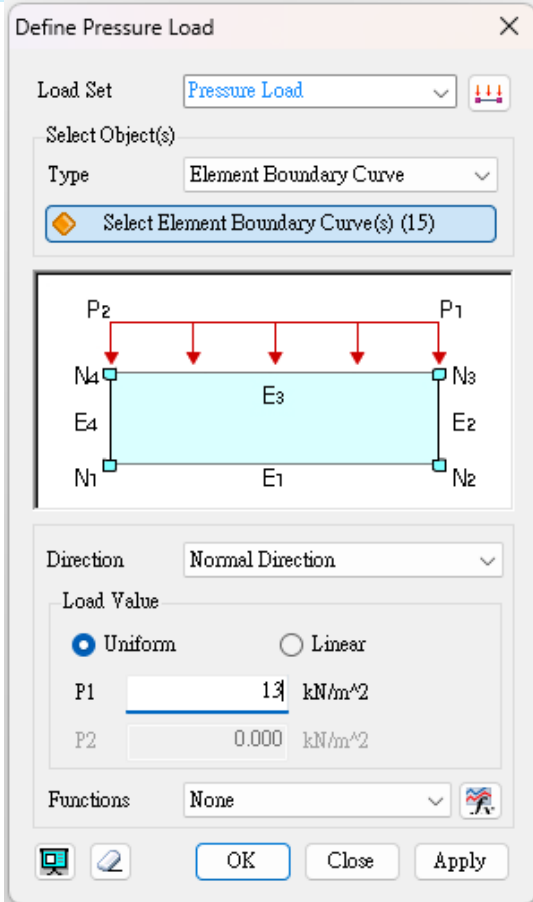

Direction : Uniform
P1= 13 (kN/m²)

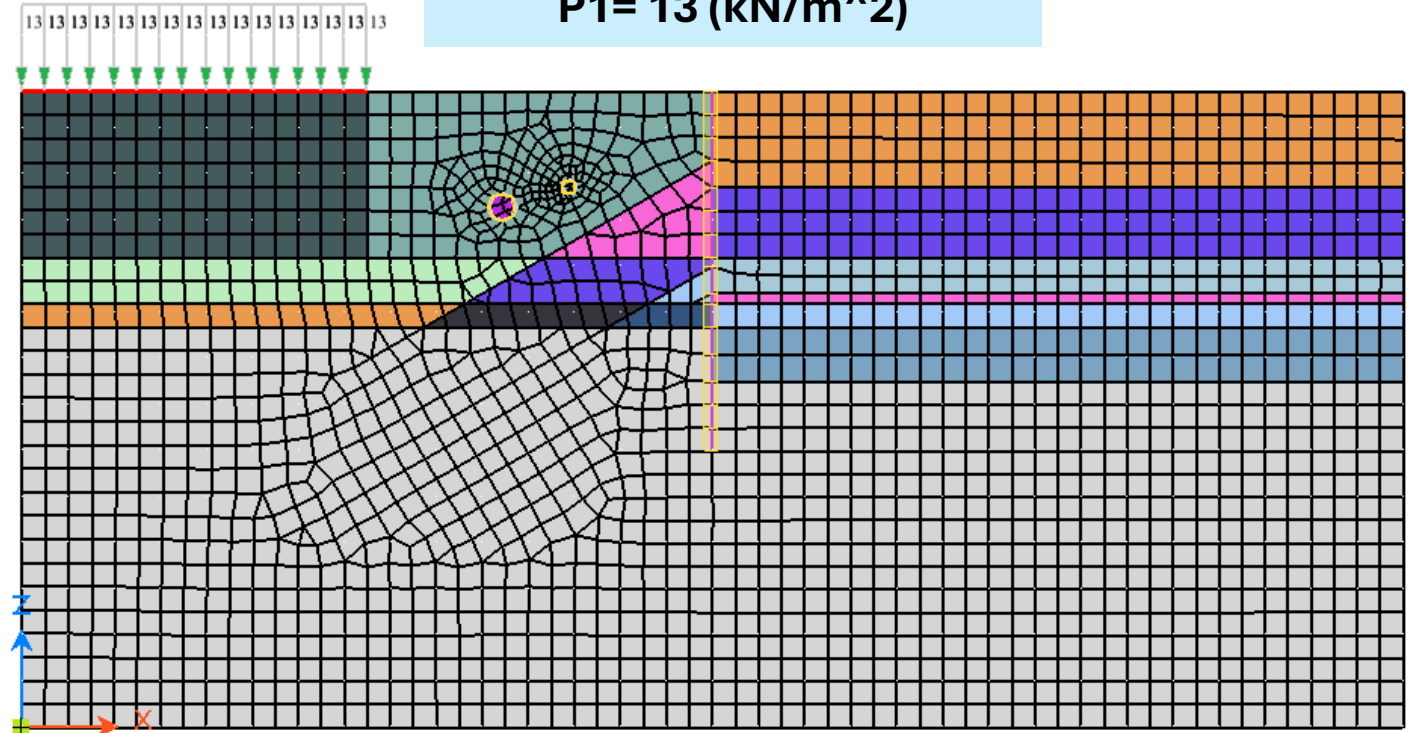

拘束條件

(自動判斷)

Loads | Boundaries 選單

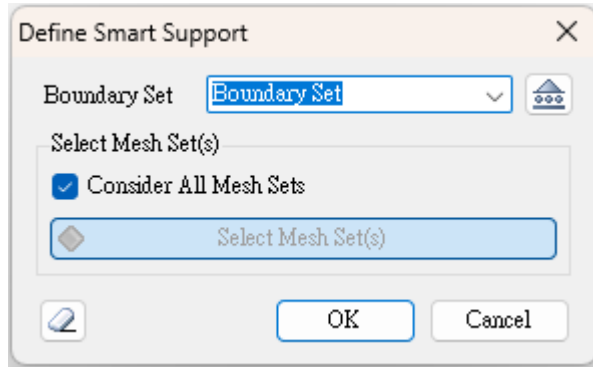

自動施加拘束條件

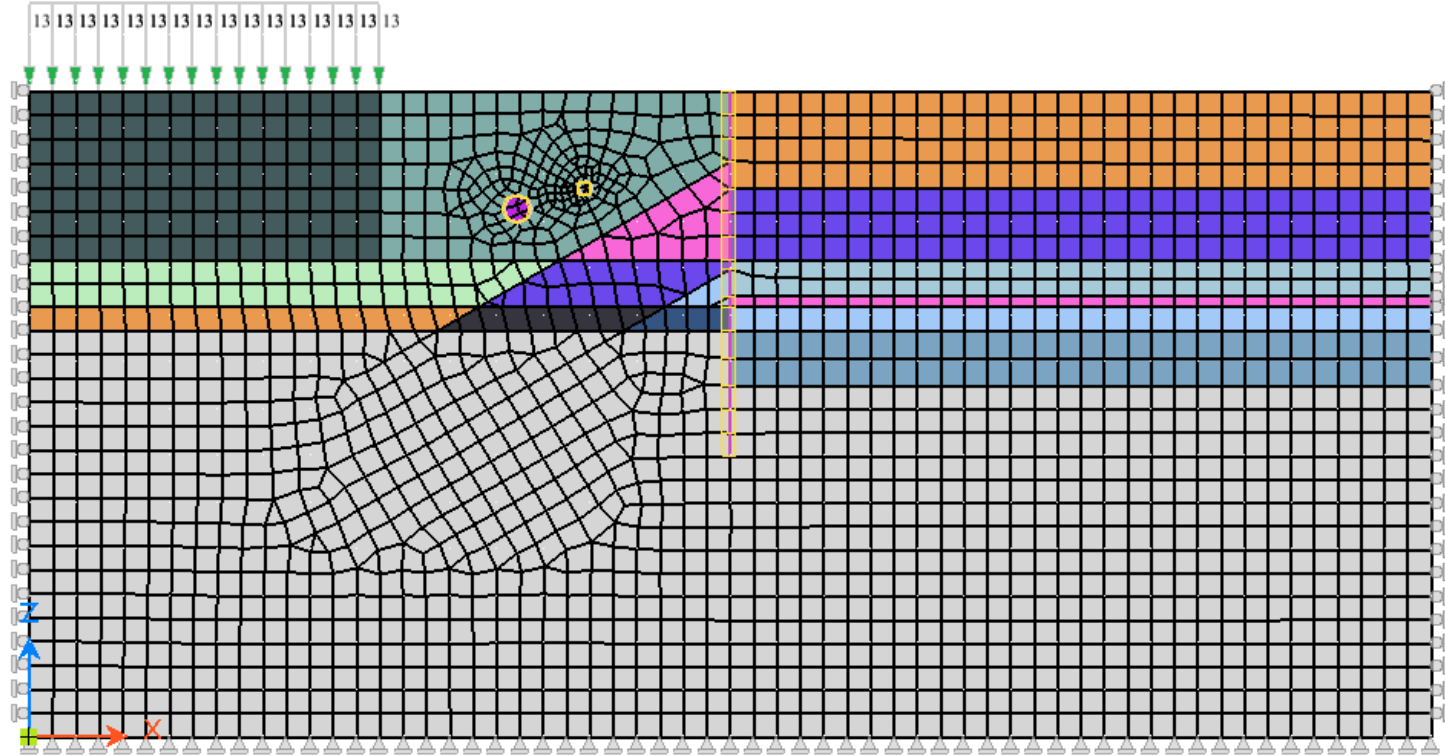

開挖計算分析說明-施工流程

(未考慮界面元素)

Part1.開挖計算
(未考慮界面元素)

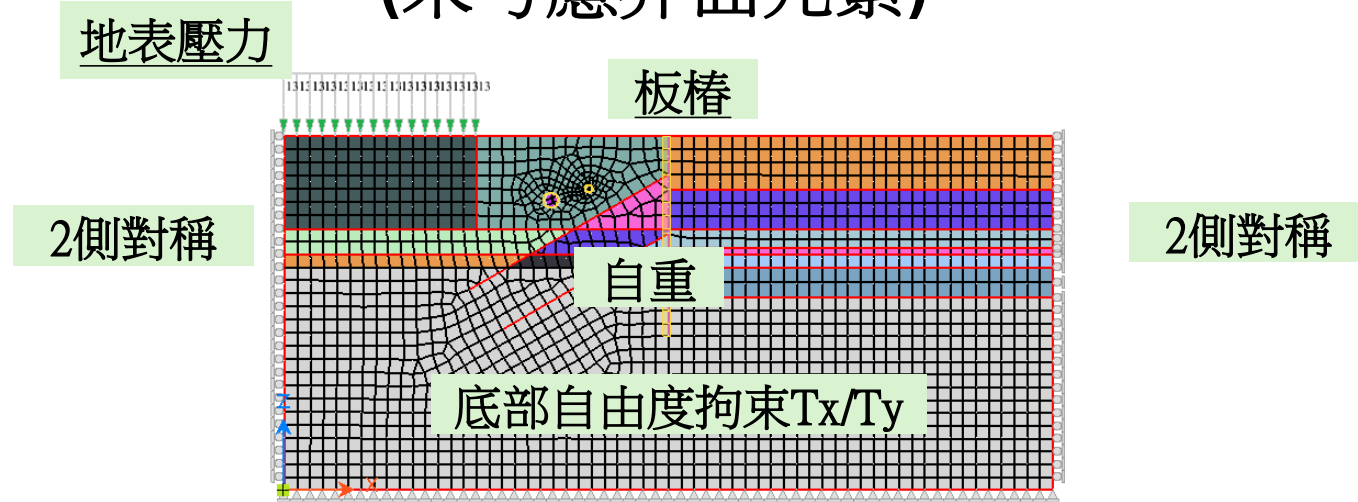

Stage1:Initial Stage

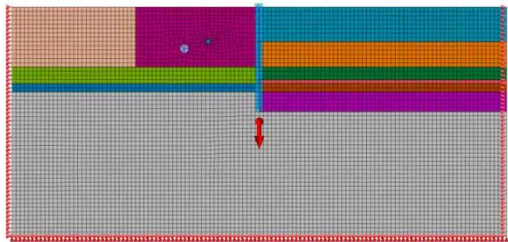

Stage2:Pipe

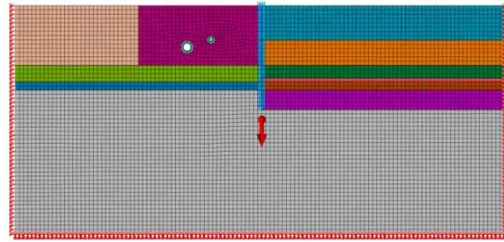

Stage3:Diaphragm&Pressure

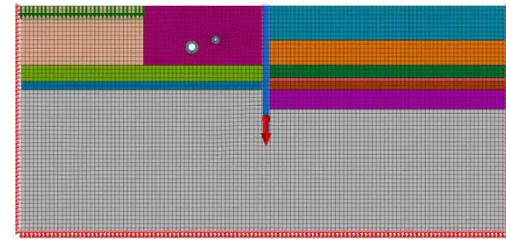

Stage4:Excavation1

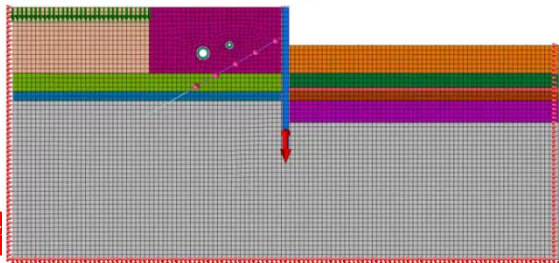

Stage5:Excavation2

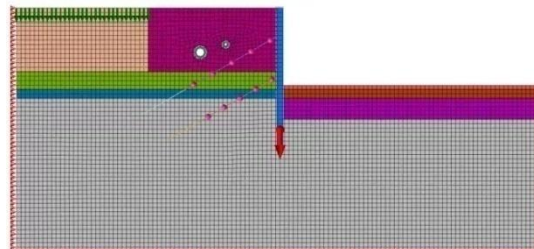

Stage6:Excavation3

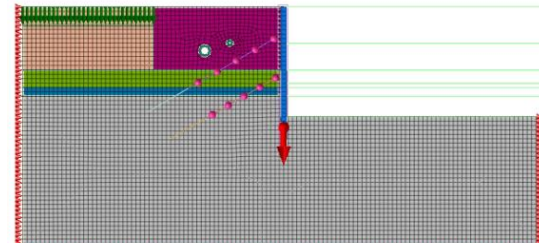

註:範例相關



施工階段新增-1

(Stage0. Initial)

施工階段

Stage0.Initial

Stage1.Pipe

Stage2.Wall and Pressure

Stage3.Excavation 1

Stage4.Excavation 2

Stage5.Excavation 3

Stage0.Initial

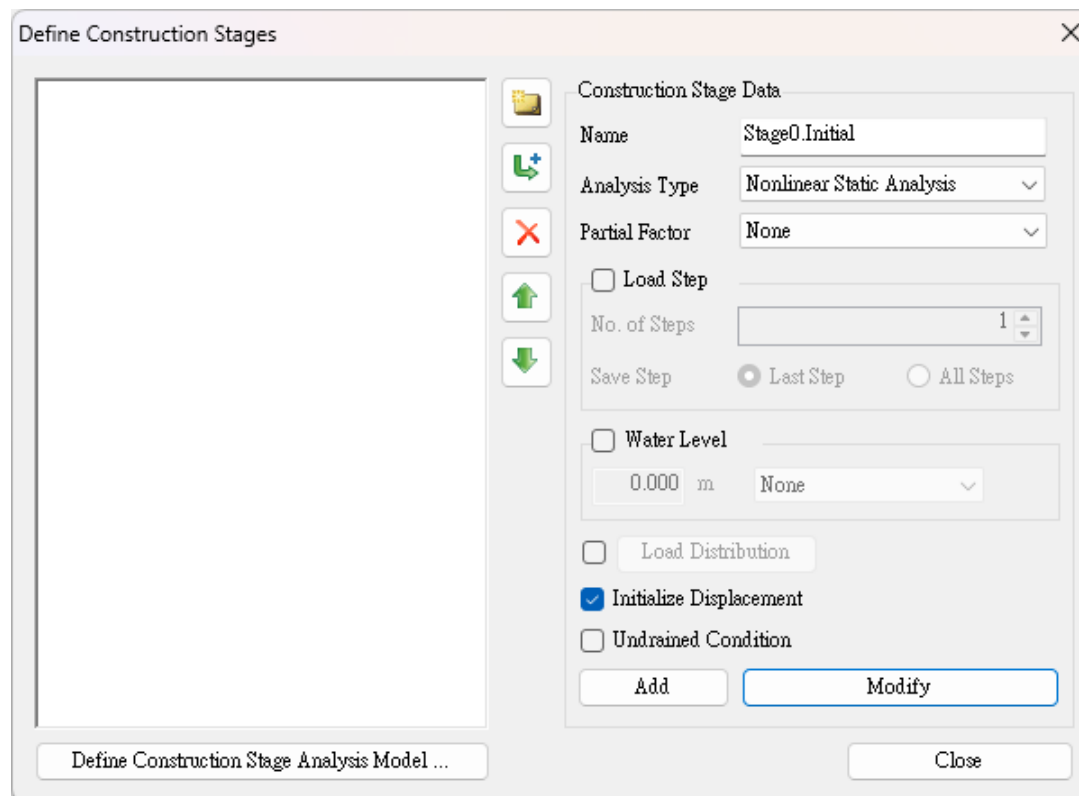

Stage0. Initial

初始位移定義

Add新增施工階段



施工階段

Stage0.Initial

Stage1.Pipe

Stage2.Wall and Pressure

Stage3.Excavation 1

Stage4.Excavation 2

Stage5.Excavation 3

施工階段新增-2

(Stage1. Pipe & Stage2.Wall and Pressure)

Stage1. Pipe

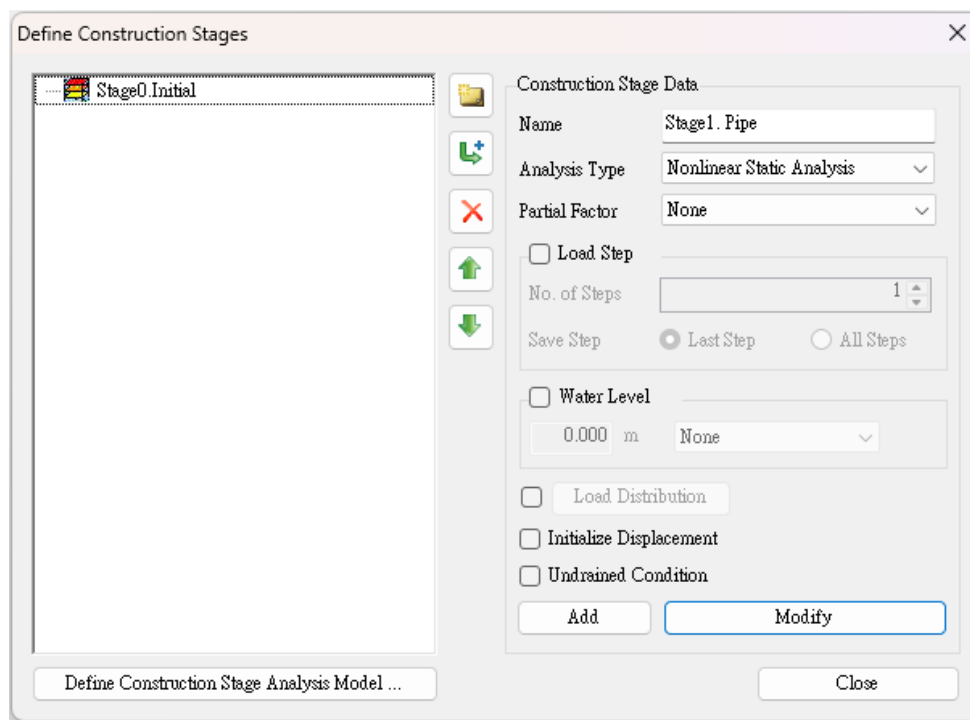

Stage2.Wall and Pressure

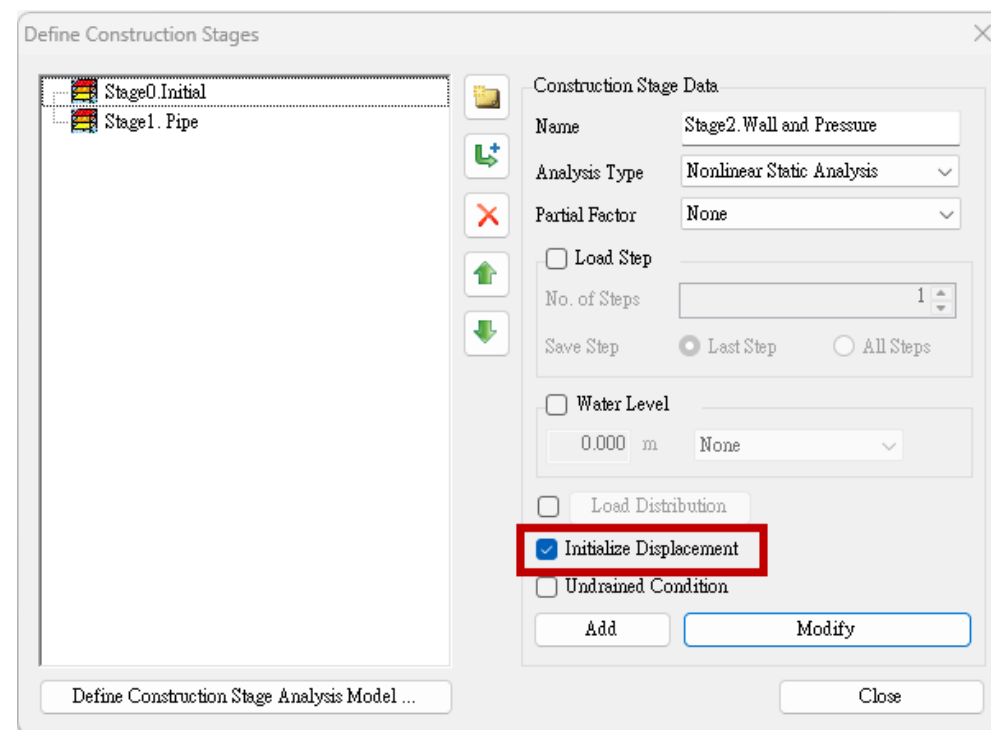

施工階段

Stage0.Initial

Stage1.Pipe

Stage2.Wall and Pressure

Stage3.Excavation 1

Stage4.Excavation 2

Stage5.Excavation 3

施工階段新增-3

(Stage3.Excavation 1 to Stage5.Excavation 3)

Stage3.Excavation 1

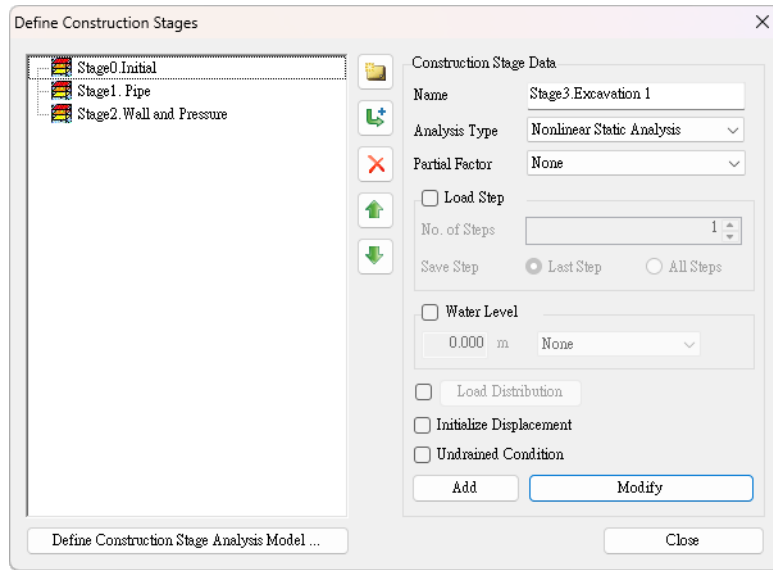

Stage4.Excavation 2

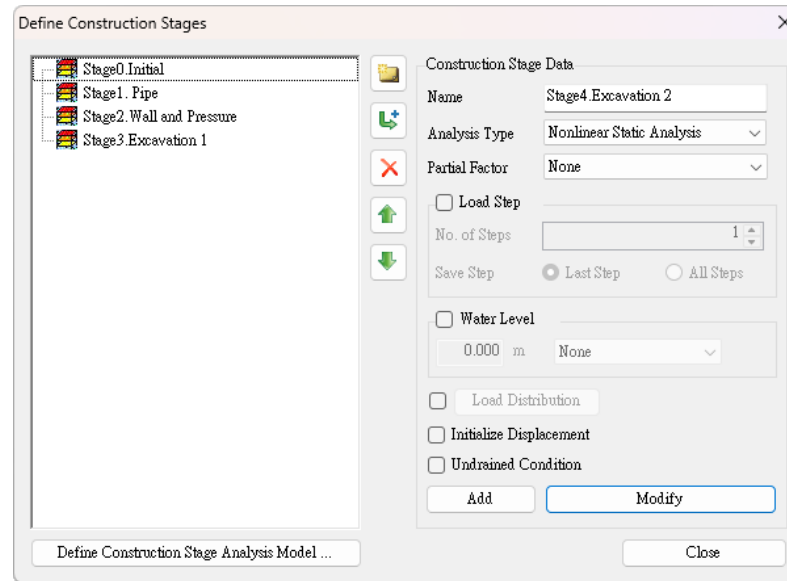

Stage5.Excavation 3

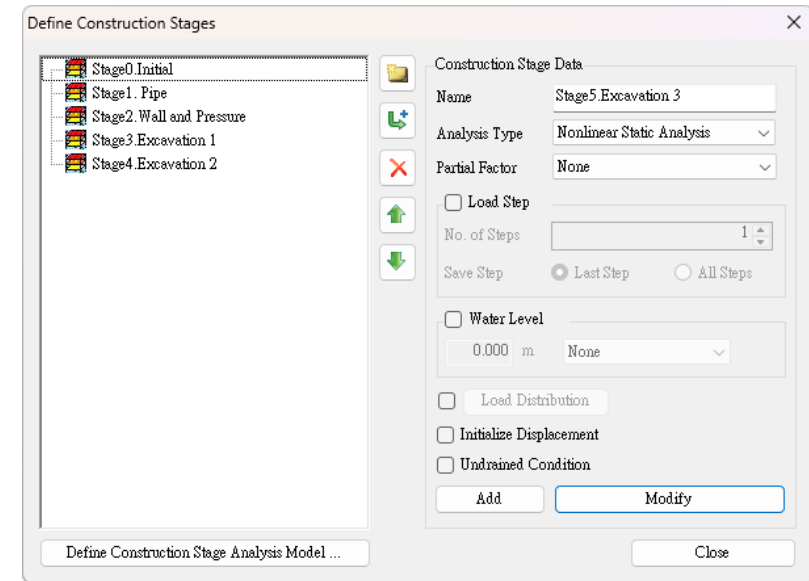



施工階段編輯-1

(Stage0. Initial)

開啟施工階段檢視

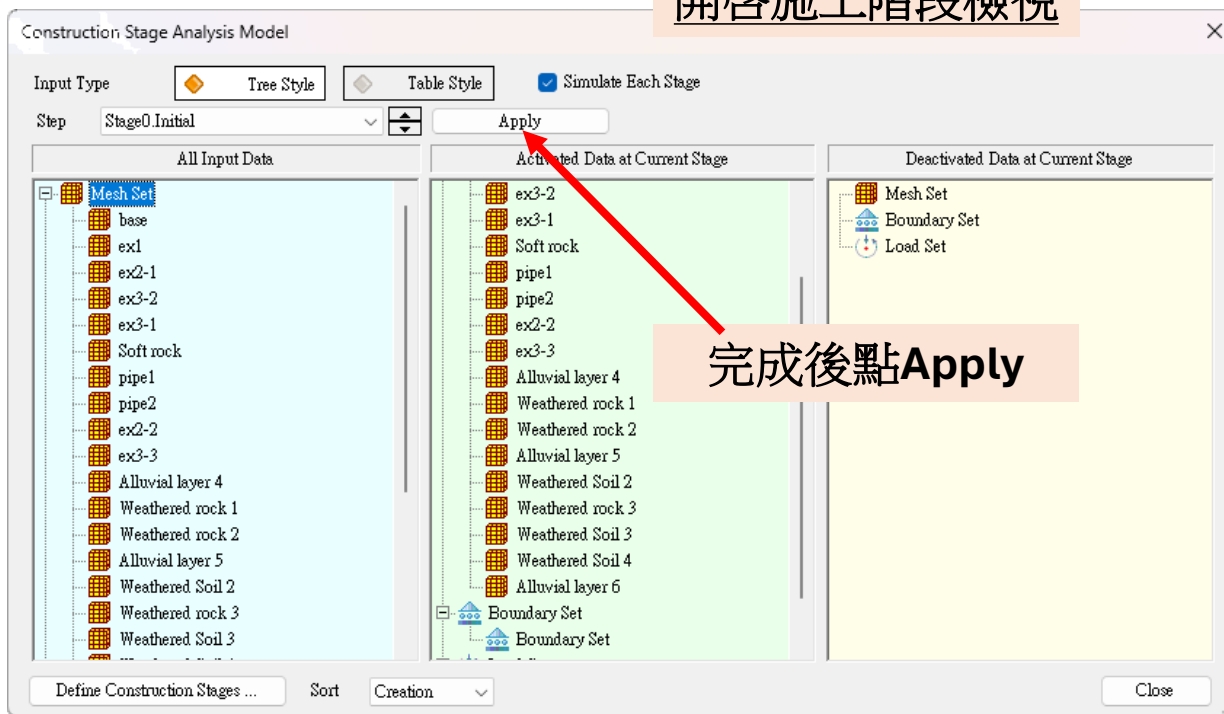

完成後點Apply

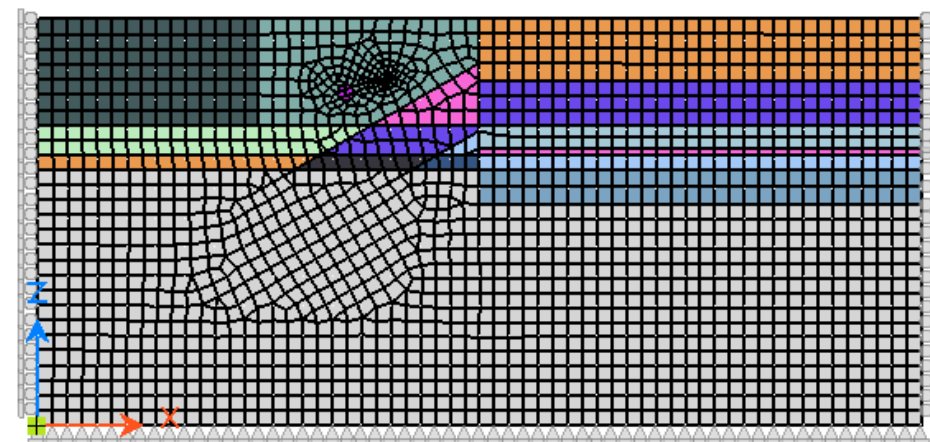

拖曳全部土壤(含開挖區域)網格集/邊界集/Self Weight載荷集



施工階段編輯-2

(Stage1. Pipe & Stage2.Wall and Pressure)

Stage1.Pipe

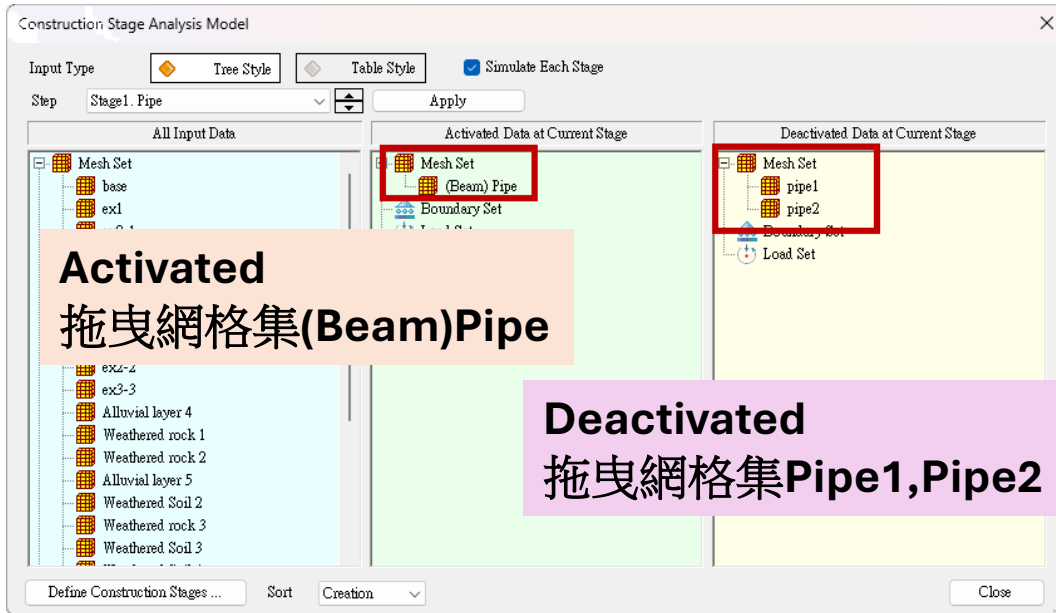

Stage2.Wall and Pressure

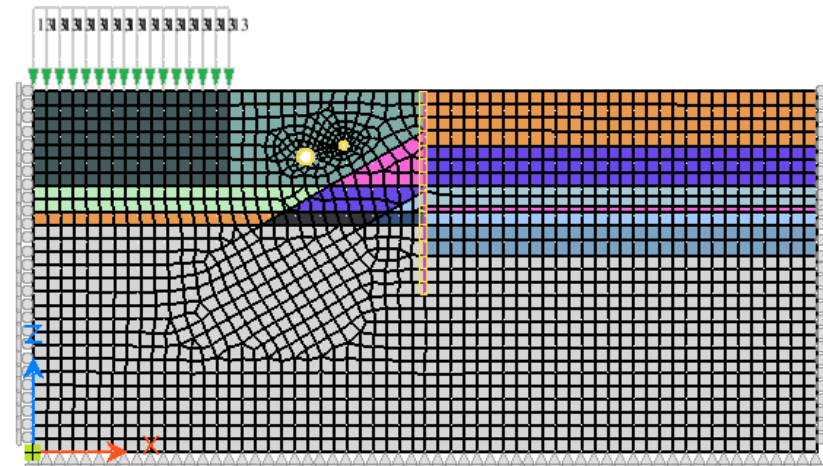
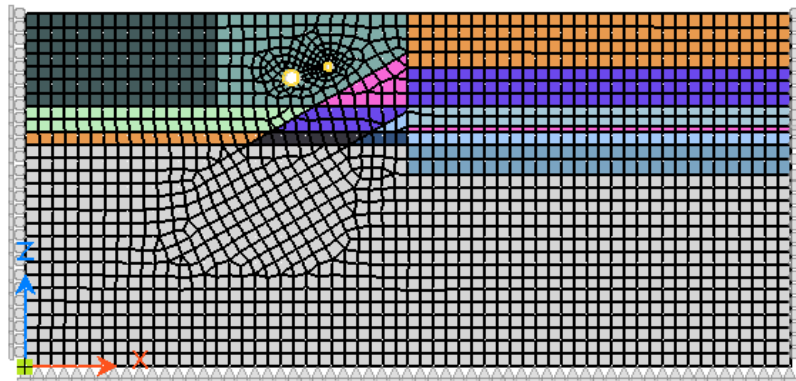
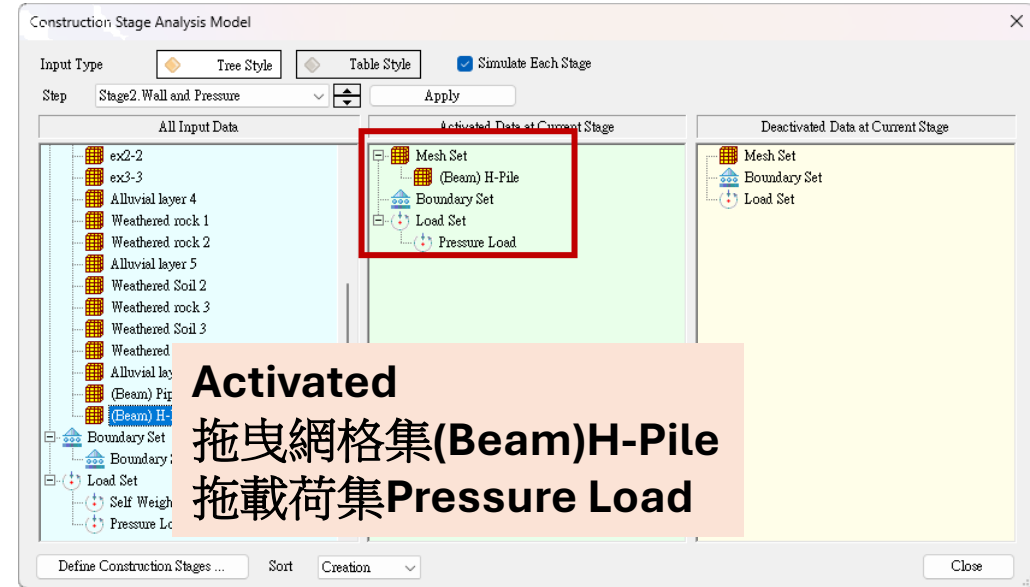

分析定義

分析名稱:Excavation/分析類型:Construction Stage

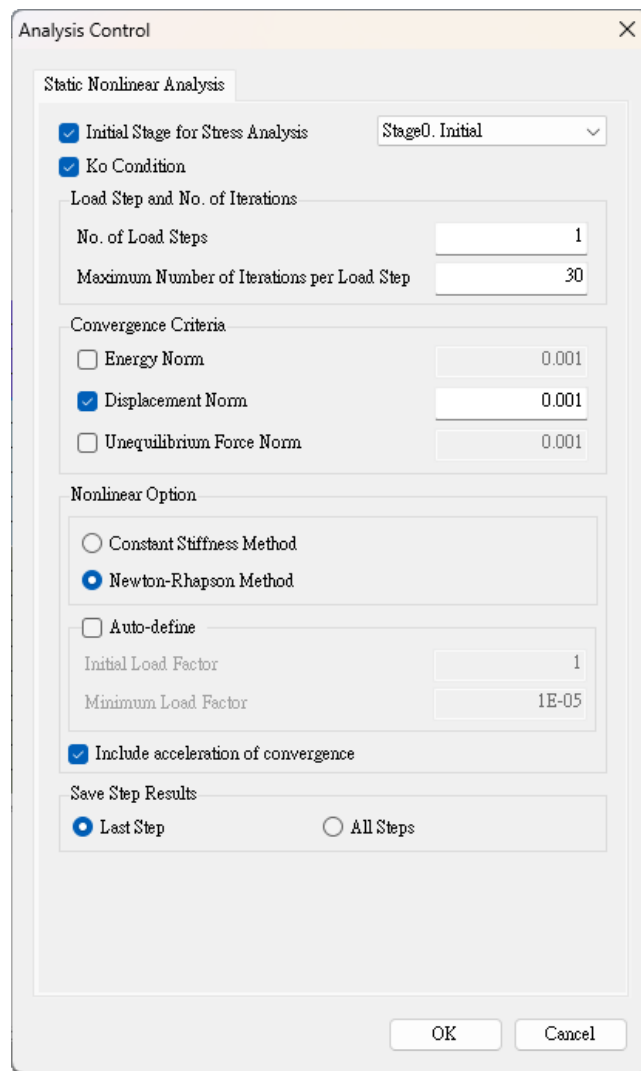
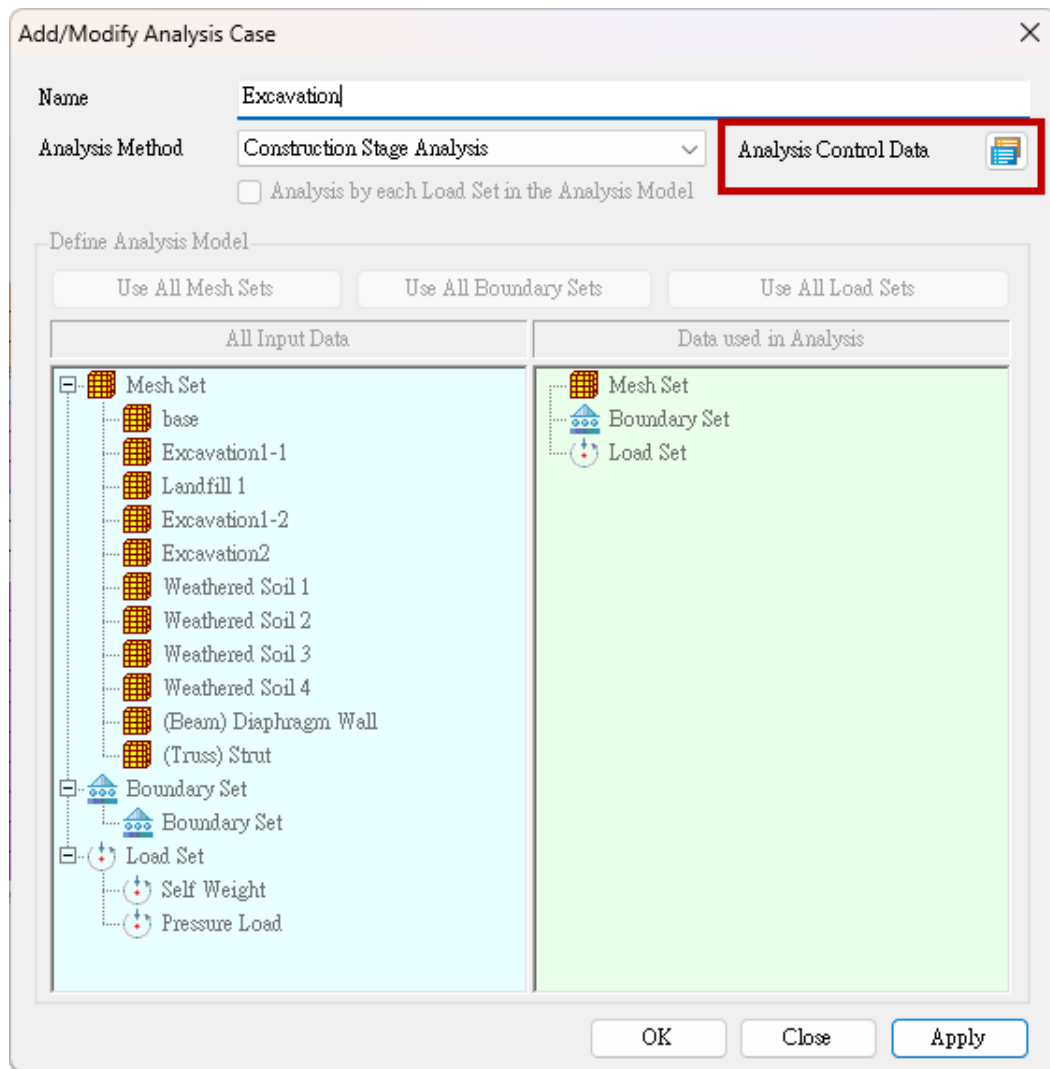
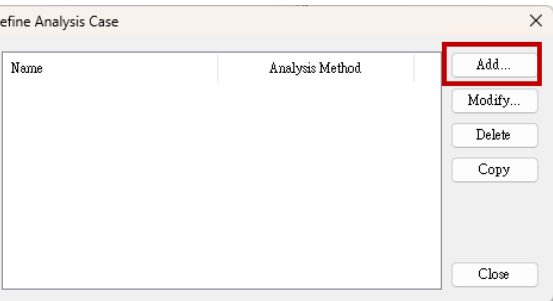
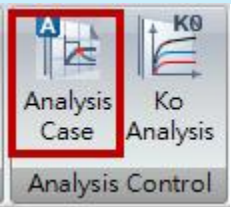

計算

SoilWorks - Soilworks_標準教學系列1_大地分析_2_設定檔_Part1開挖計算 [Ground Module]

Geometry | Model | Loads | Boundaries | Analysis | Design | Results | Tools | Window

Analysis Manager

<input checked="" type="checkbox"/>	Name	Analysis Type
<input checked="" type="checkbox"/>	Excavation	Construction Stage Analysis

執行求解

Perform Analysis | Cancel Analysis | Close

Message

```
Command : RUNANALYSIS
Command : RUNANALYSIS
Perform : Analysis Case data (Number=1) has been generated.
Command : ANALYSISCASE
Command : RUNANALYSIS
```

Analysis Manager

<input checked="" type="checkbox"/>	Name	Analysis Type
<input checked="" type="checkbox"/>	Excavation	Construction Stage Analysis

STEP ID : 1 ITERATION NO. : 1 TOLERANCE : 0.0000E+00 CONVERGED
ANALYSIS TYPE : NONLINEAR_STATIC STAGE ID : 4
STEP ID : 1 ITERATION NO. : 1 TOLERANCE : 0.0000E+00 CONVERGED
ANALYSIS TYPE : NONLINEAR_STATIC STAGE ID : 5
STEP ID : 1 ITERATION NO. : 3 TOLERANCE : 0.1342E-04 CONVERGED
ANALYSIS TYPE : NONLINEAR_STATIC STAGE ID : 6
STEP ID : 1 ITERATION NO. : 3 TOLERANCE : 0.1144E-03 CONVERGED

ANALYSIS IS FINISHED
TOTAL ELAPSED TIME IS 3.28 SECONDS

計算迭代過程

Perform Analysis | Cancel Analysis | Close



開挖分析結果

依照施工階段定義順序
輸出6組結果

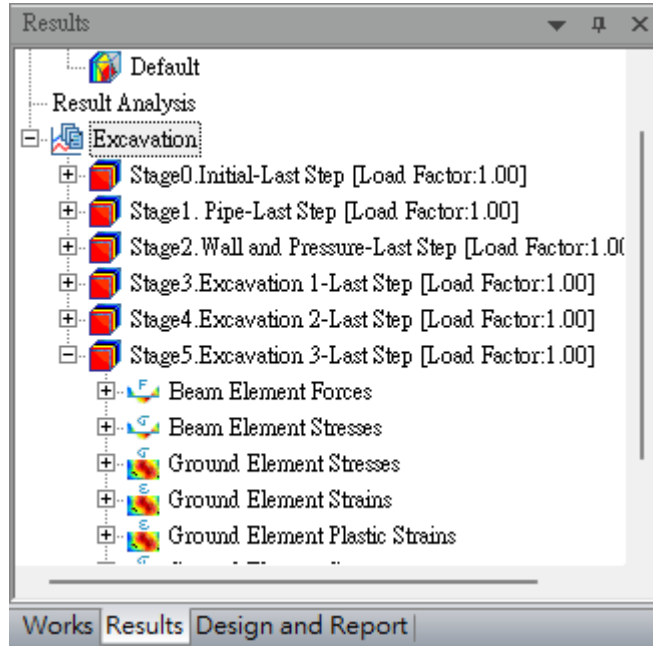

各類分析顯示定義

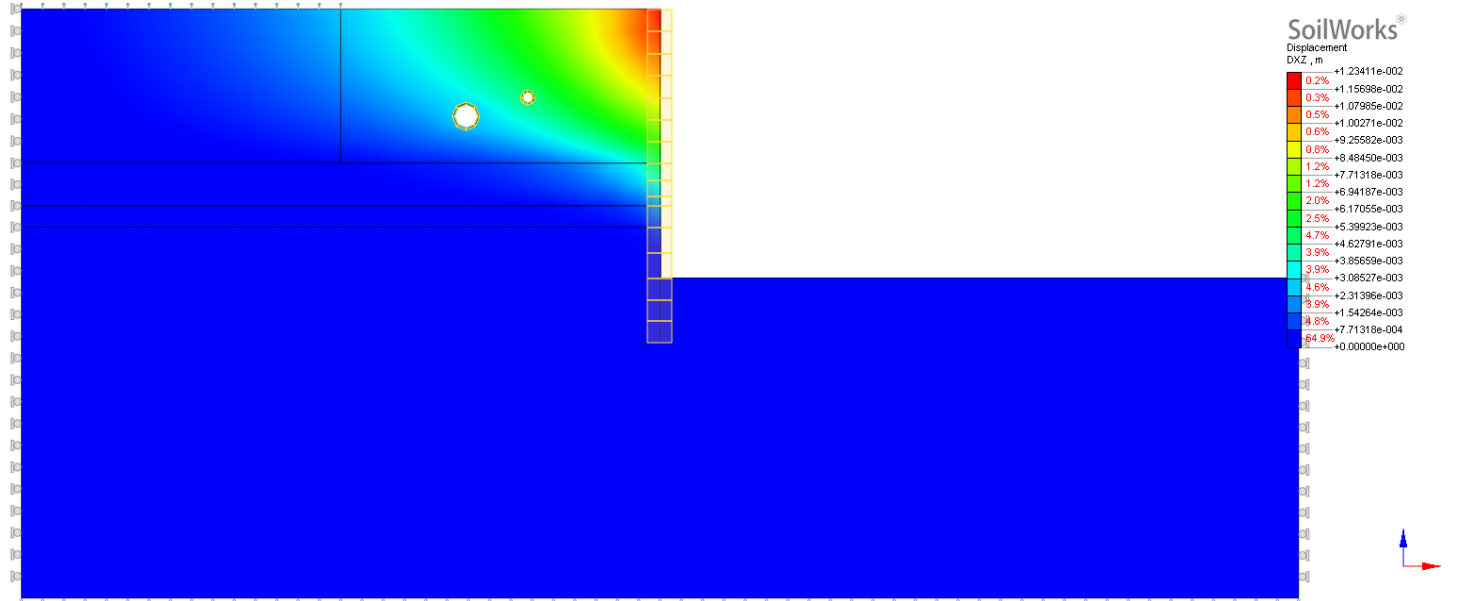

影片播放



Part2.開挖計算+地錨

(未考慮界面元素)



Anchors地錨

地錨係土錨與岩錨的統稱，地錨將所需拉力由主要結構體傳遞至周圍緊密地層中，由地層之抗剪強度提供足夠摩擦阻抗，使地錨、主要結構體及錨碇段周圍地層三者達到平衡狀態。

地錨構造

錨碇段：提供錨碇力的部分

自由段：抗張材受拉伸張及傳遞錨碇力至錨頭之部分

錨頭：承受鎖定抗張材及傳遞錨碇力至承壓結構體之部分

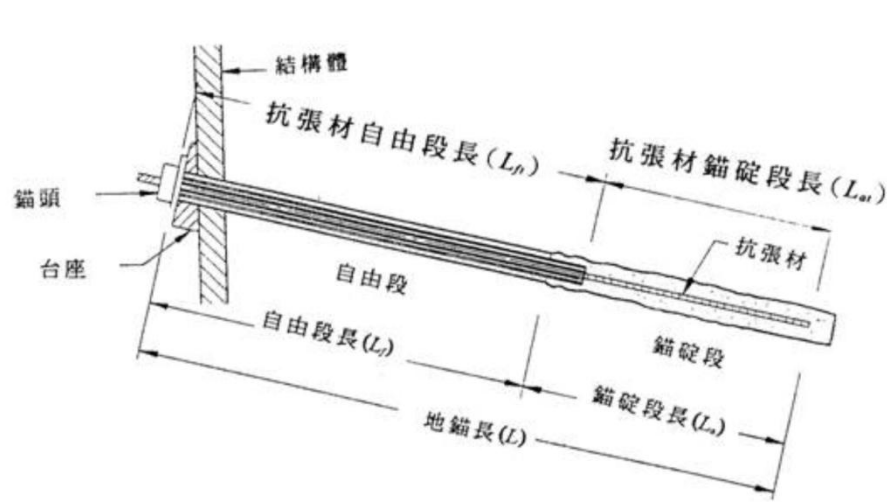

地錨構造示意圖

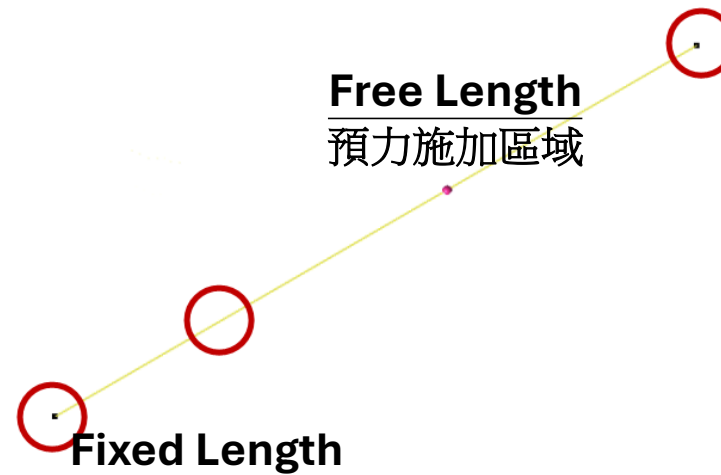

分析採二段建模

Anchor Element

(Truss Element/Embedded Truss Element)

Truss Element

Truss elements are a 1D line element defined by 2 nodes.

They are generally used to model space Trusses or diagonal braces that have a relatively longer length than the cross section. It is generally used for modeling structural elements such as anchors, nails and rockbolts, which ignore flexural behavior.

Embedded Truss Element

Embedded truss elements do not require node sharing and are hence more convenient for modeling and analysis. Embedded truss elements are used in an embedded form inside a mother element, and the mother element can be a plane strain element or a solid element.

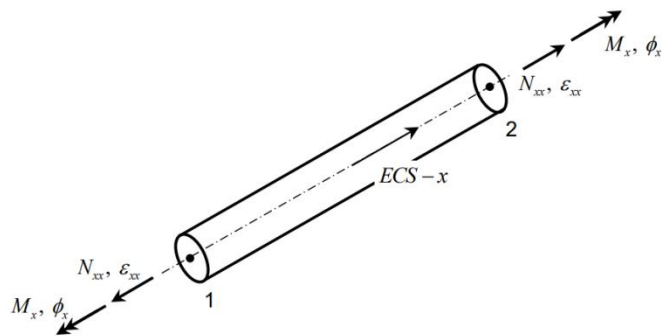

Truss Element

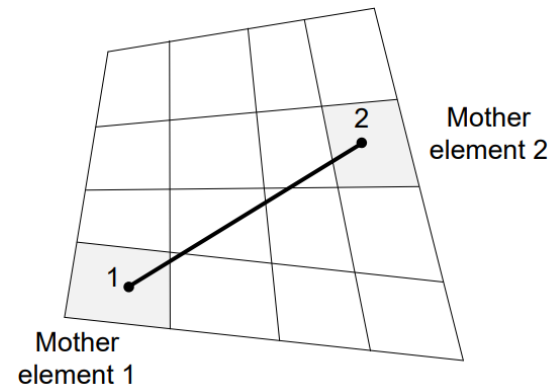

Embedded Truss Element



Anchor元素生成-1

(手動)

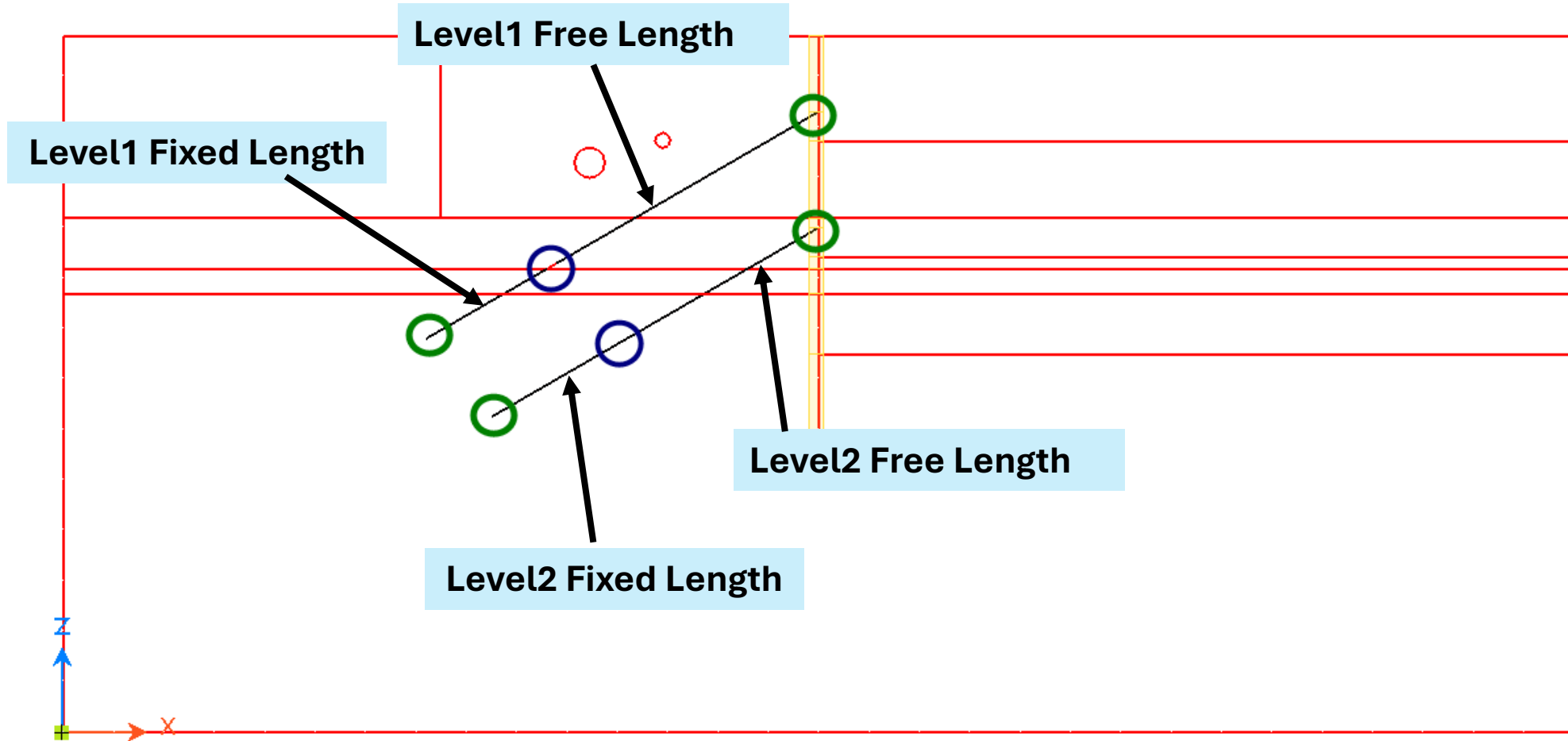

Anchor元素生成-2

(Fixed Length)

Model選單> Element

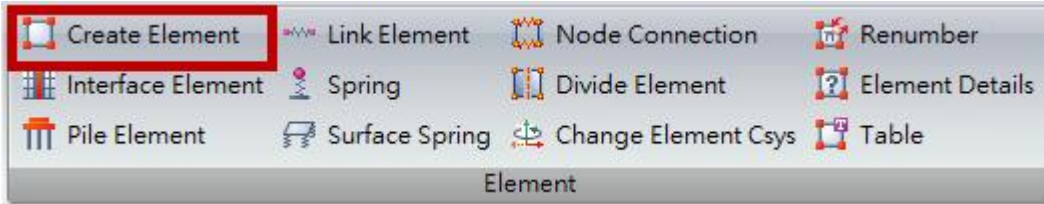

Mesh Set : Level1 Fixed Length
(Embedded Truss Element/Anchor)

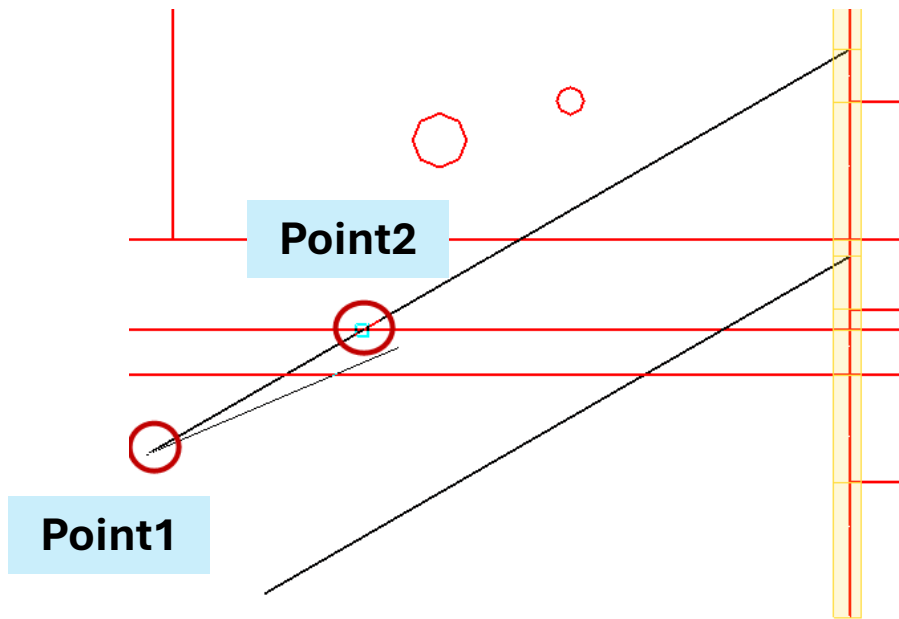

Mesh Set : Level2 Fixed Length
(Embedded Truss Element/Anchor)

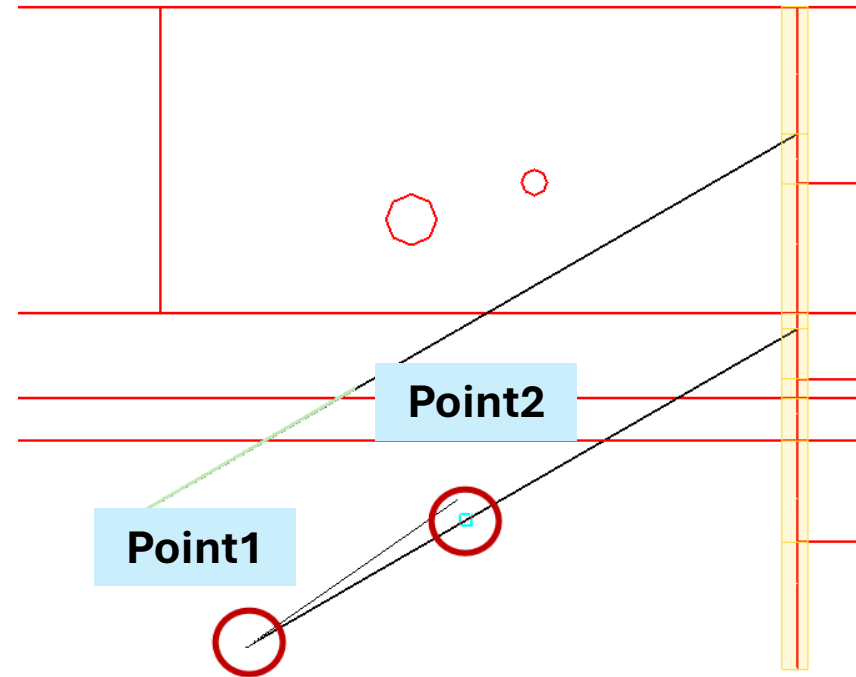

Anchor元素生成-3

(Free Length)

Model選單> Element

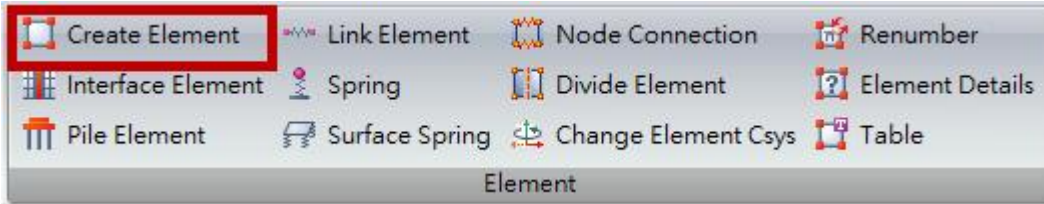

Mesh Set : Level1 Free Length
(Embedded Truss Element/Anchor)

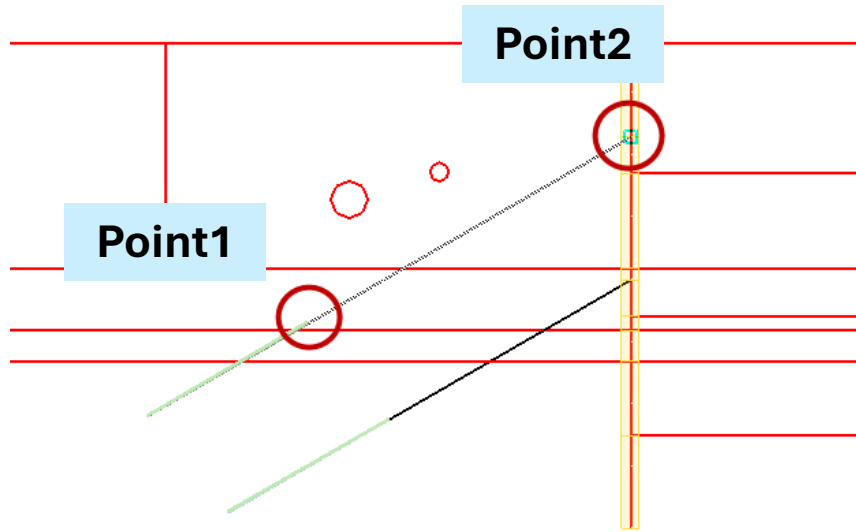

Mesh Set : Level2 Free Length
(Embedded Truss Element/Anchor)

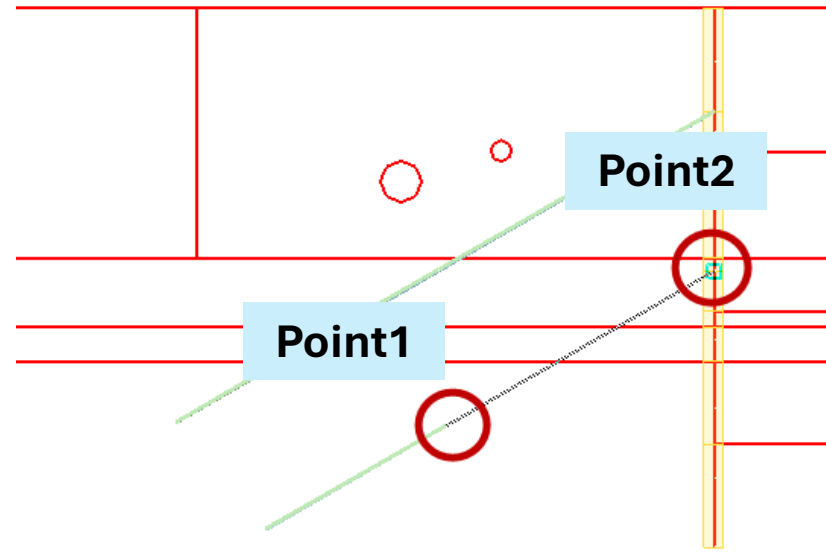

預力施加

Loads | Boundaries 選單

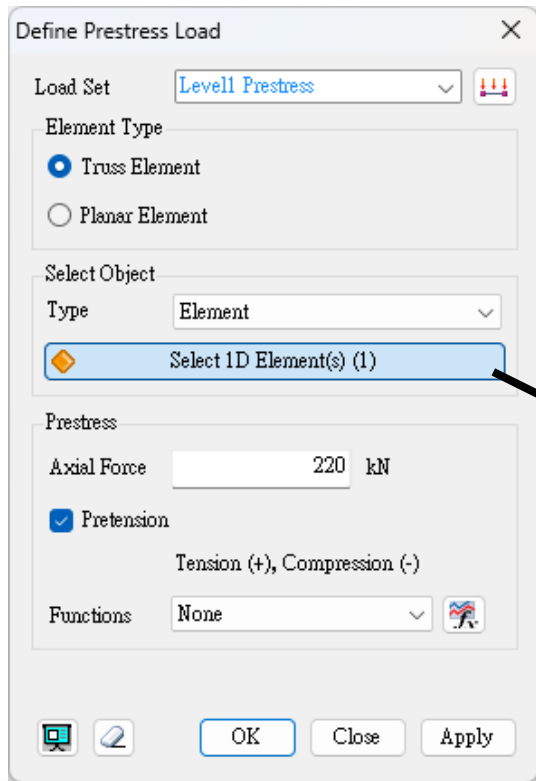
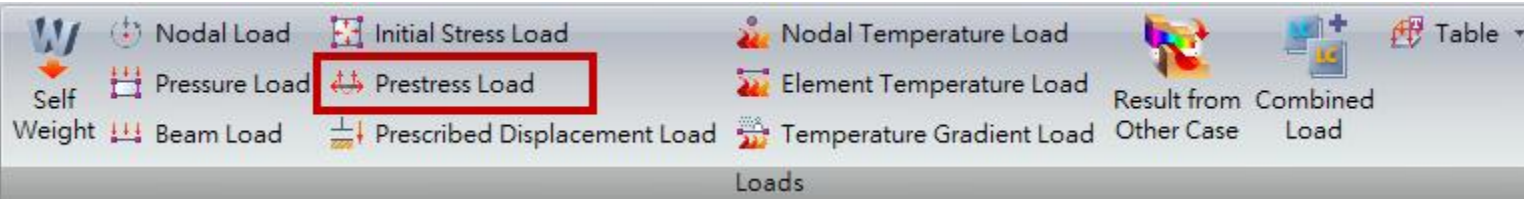

Load Set : Level 1 Prestress (Pretension/220KN)

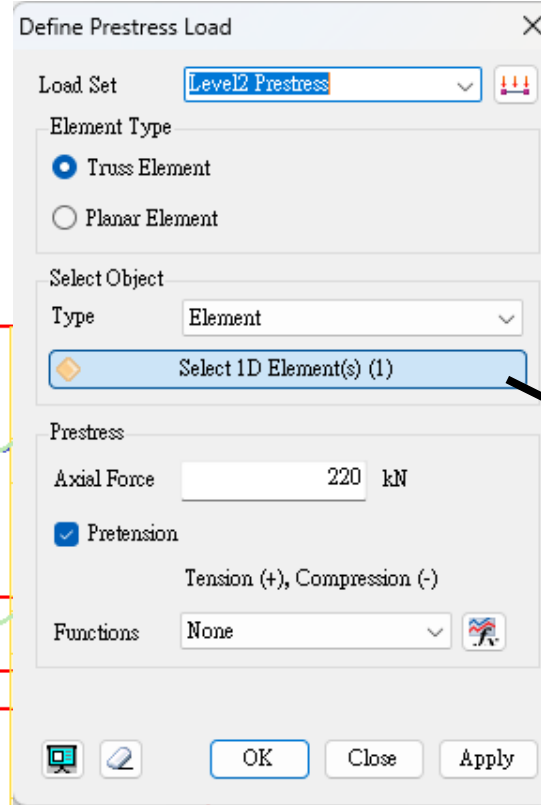
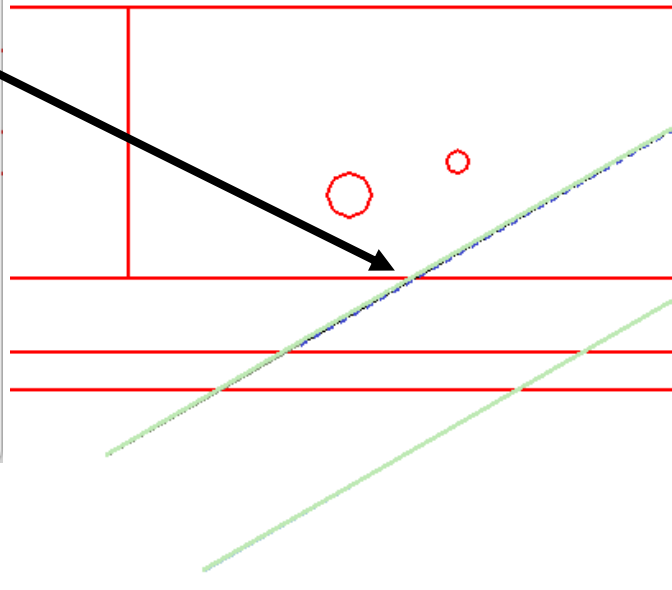

Load Set : Level 2 Prestress (Pretension/220KN)

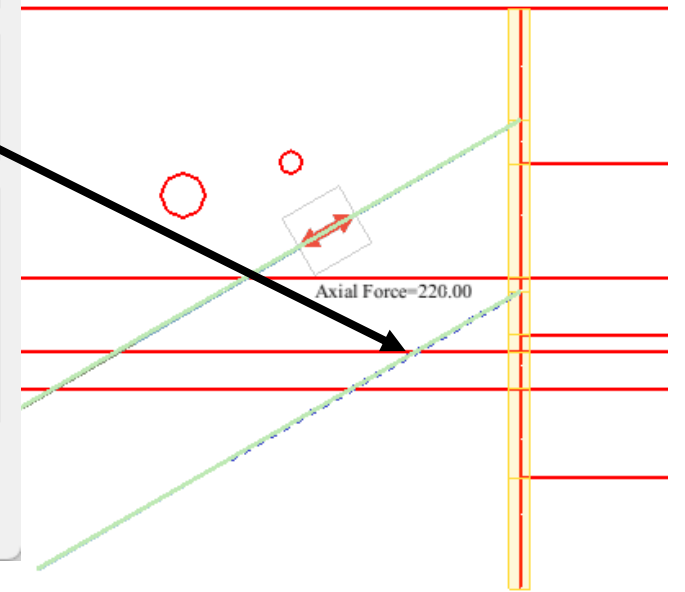

地錨施工階段編輯

(Stage3.Excavation 1 and Stage4.Excavation 2)

Stage3.Excavation 1

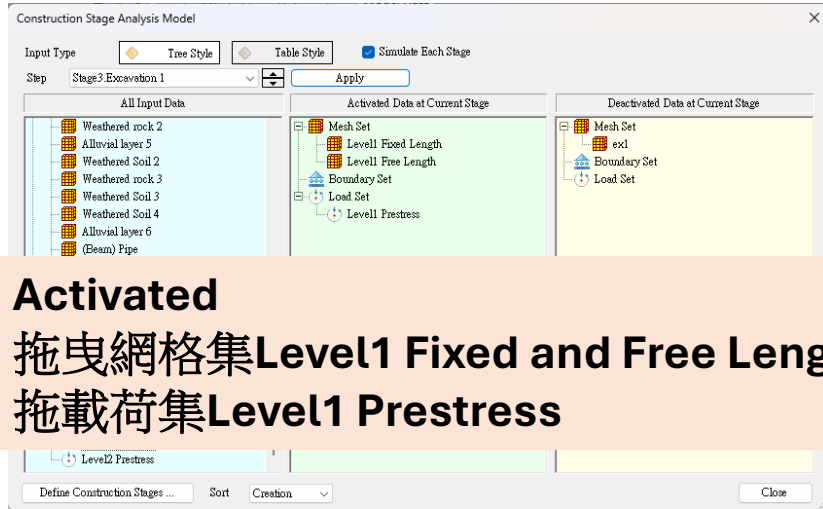

Stage4.Excavation 2

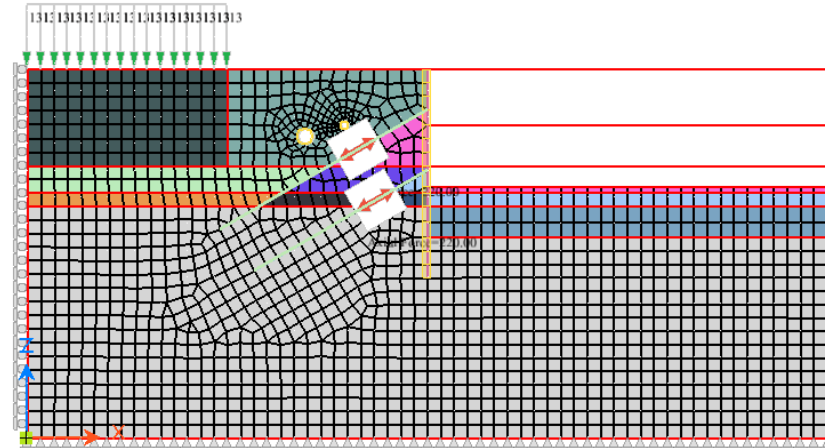
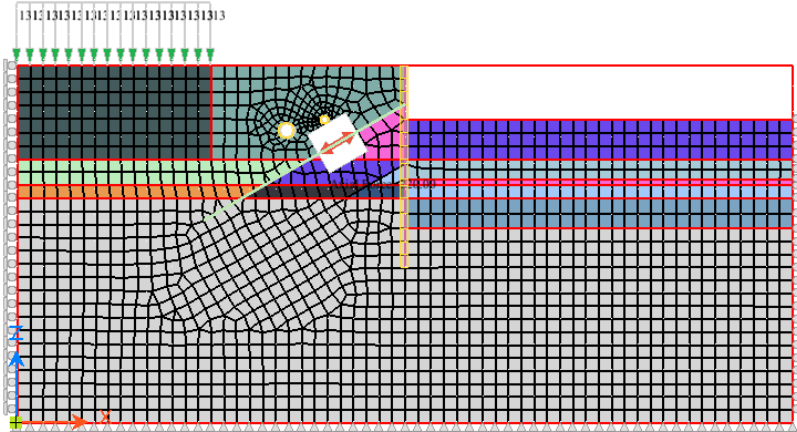

開挖+地錨分析結果

依照施工階段定義順序
輸出6組結果

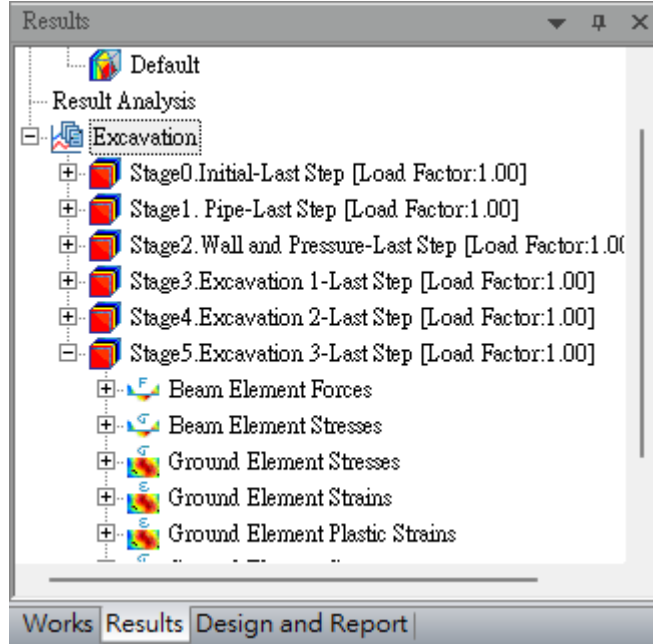

各類分析顯示定義

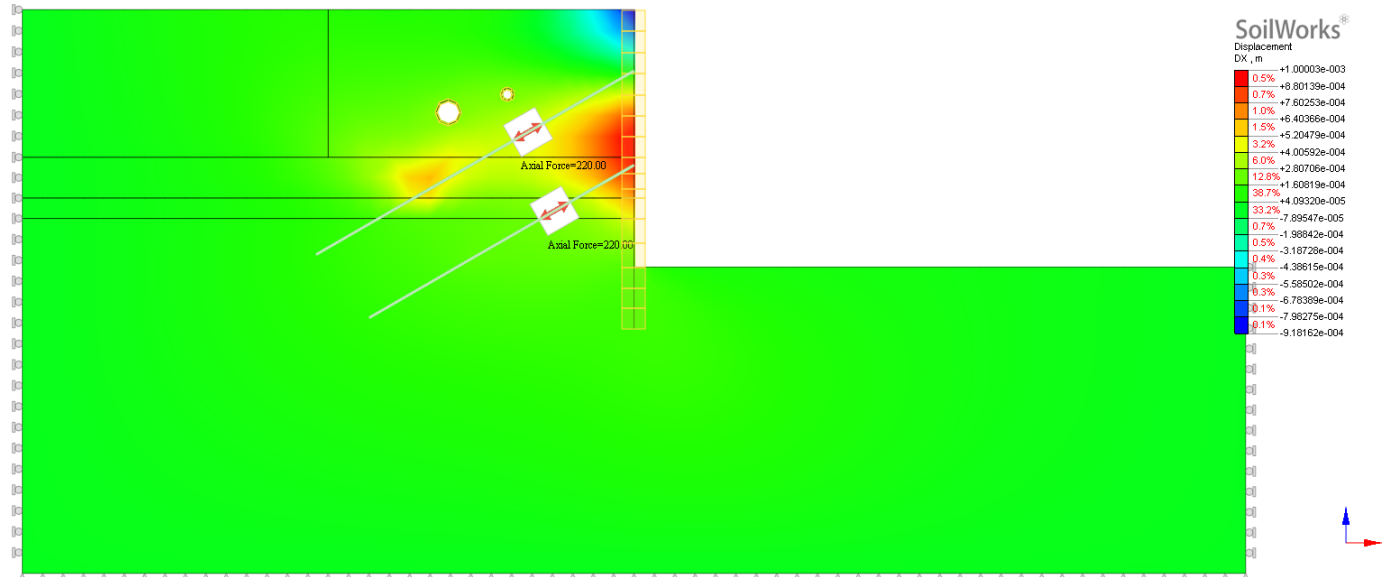

影片播放

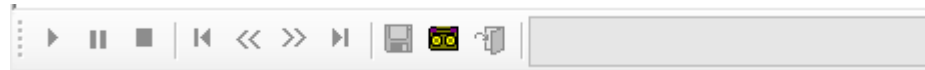

檔案:Soilworks_標準教學系列1_大地分析_2_設定檔_Part2開挖計算+地錨



Part3. 界面元素



界面元素

(Interface Elements)

[Normal stiffness modulus (Kn)]-法向剛度模量

Is the Elasticity modulus for **bonding and un-bonding behavior** in the normal direction to the interface element.

The general range is 10~100 times the smallest value of the Elasticity modulus on the oedo meter of adjacent elements.

[Shear stiffness modulus (Kt)]-剪切剛度模量

Is the Elasticity modulus for **slip behavior** in the normal direction to the interface element.

The general range is 10~100 times the smallest value of the shear strength of adjacent elements.

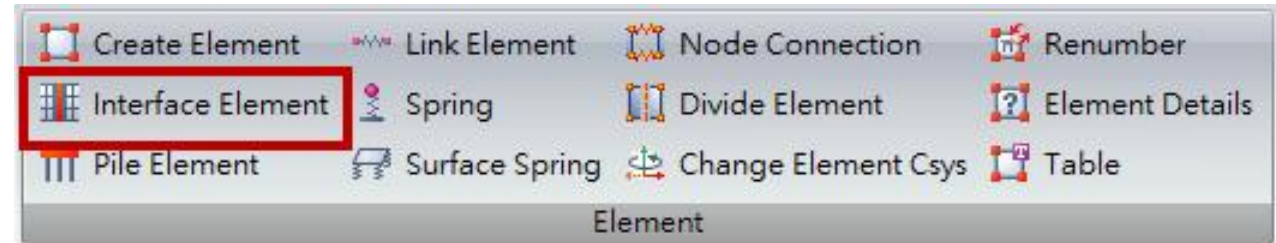

Reference

GTS NX & FEA NX Manual

界面-嚮導模組-1

(Interface Wizard)

- **GTS NX**界面元素嚮導模式
 - 自動推估法向剛度 (K_n)&切向剛度(K_t)
- **Virtual Thickness Factor** 虛擬厚度係數 (t_v)
 - 數值0.01~0.1範圍。
 - 剛度大使用較小的值。
- **Strength Reduction Factor**強度折減係數(R)
 - Sandy soil/Steel material = R : 0.6~0.7 砂土/鋼材
 - Clay/Steel material = R : 0.5 粘土/鋼材
 - Sandy soil/Concrete = R : 1.0~0.8 沙土/混凝土
 - Clay/Concrete = R : 1.0~0.7 粘土/混凝土

Property	
Virtual Thickness Factor (t_v)	0.5
Strength Reduction Factor (R)	1
<input type="checkbox"/> Dilatancy Angle	0.000 [deg]
<input type="checkbox"/> Consider Element Size	

$$K_n = E_{oed,i} / t_v$$

$$K_t = G_i / t_v$$

$$C_i = R^2 \times C_{soil}$$

Here,

$$E_{oed,i} = 2 \times G_i \times (1 - \nu_i) / (1 - 2 \times \nu_i)$$

$$G_i = R^2 \times G_{soil}$$

$$G_{soil} = E / (2(1 + \nu_{soil}))$$

K_n : Normal Stiffness Modulus(法向剛度模量)

K_t : Shear Stiffness Modulus(剪切剛度模量)

t_v : Virtual thickness factor (虛擬厚度係數)

R : Strength reduction factor(強度折減係數)

C_i : Interface Cohesion(界面內聚力)



界面-嚮導模組-2

(Interface Wizard)

- **Consider Element Size**考慮元素大小

- 透過相鄰地面元素的平均長度(line)和平均面積(face)來計算界面材料屬性。
- 如果不勾選，將採用單位長度。
- 大部份分析如果沒有確切的值，建議使用程序中設置的默認值。
- 當計算土壤硬化時，厚度是一個重要因素，必須要考慮。

$$K_n = E_{oed,i} / t_v$$
$$K_t = G_i / t_v$$



$$K_n = E_{oed,i} / (l \text{ or } \sqrt{A} \times t_v)$$
$$K_t = G_i / (l \text{ or } \sqrt{A} \times t_v)$$

l:平均長度 (l)

A:平均面積 (A)

Property	
Virtual Thickness Factor (tv)	0.5
Strength Reduction Factor (R)	1
<input type="checkbox"/> Dilatancy Angle	0.000 [deg]
<input type="checkbox"/> Consider Element Size	

- **Conduction for seepage flow**滲流傳導=>GTS NX

- 如果不勾選滲流傳導，則假定為不透水層。
- 當界面元素定義滲流剛度時，可以參考地面滲透係數定義。

Interface 元素生成

Model 選單 > Element

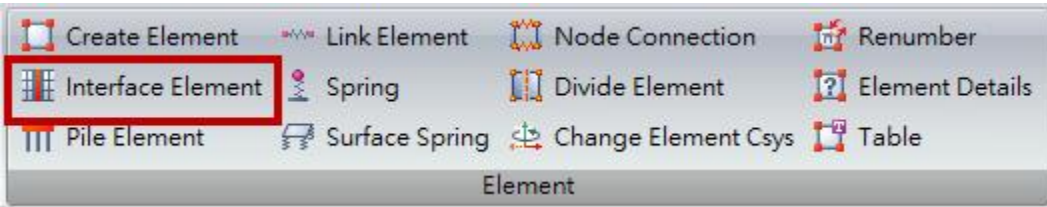

Structural Element
只顯示 H-Pile (Beam)

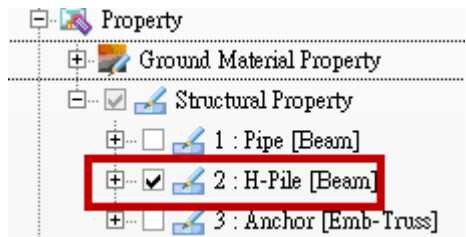

使用界面-嚮導模組預設參數

Mesh Set : Interface

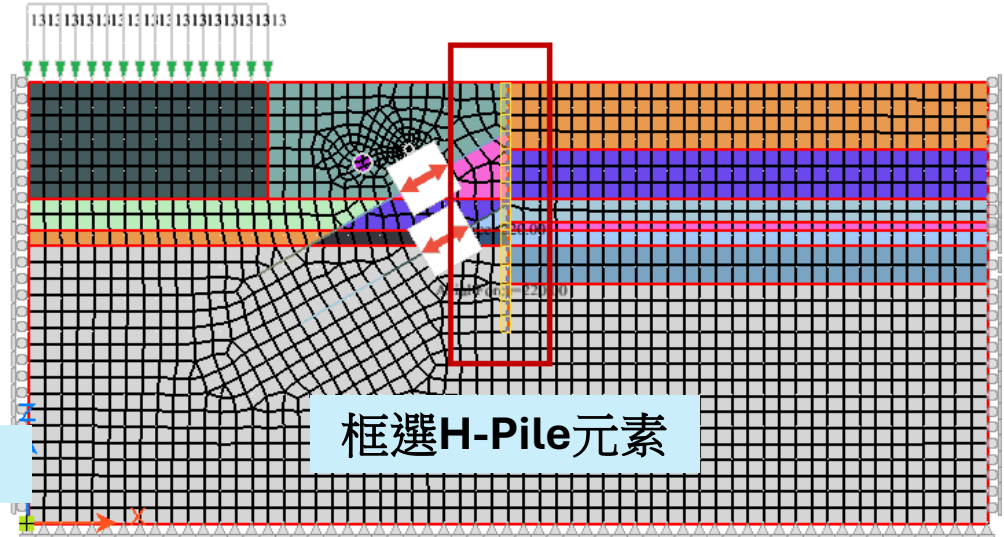
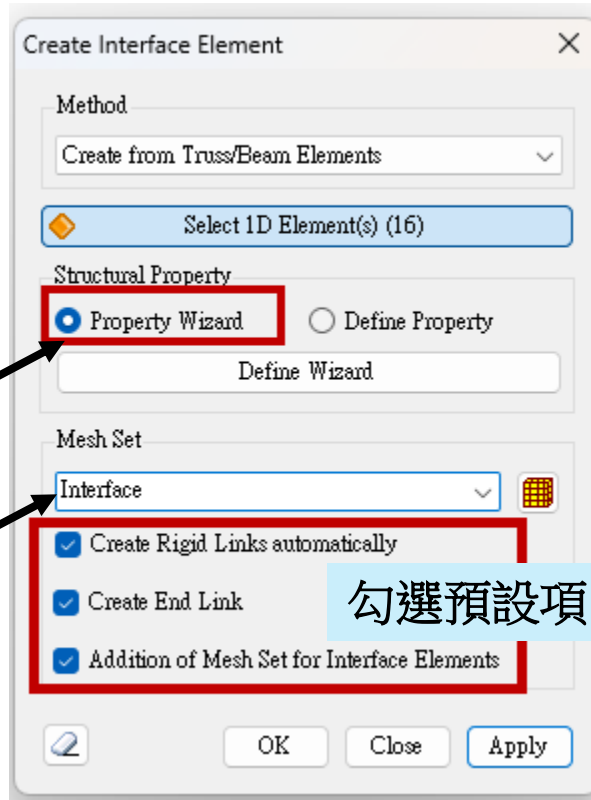

補充:Interface元素集合

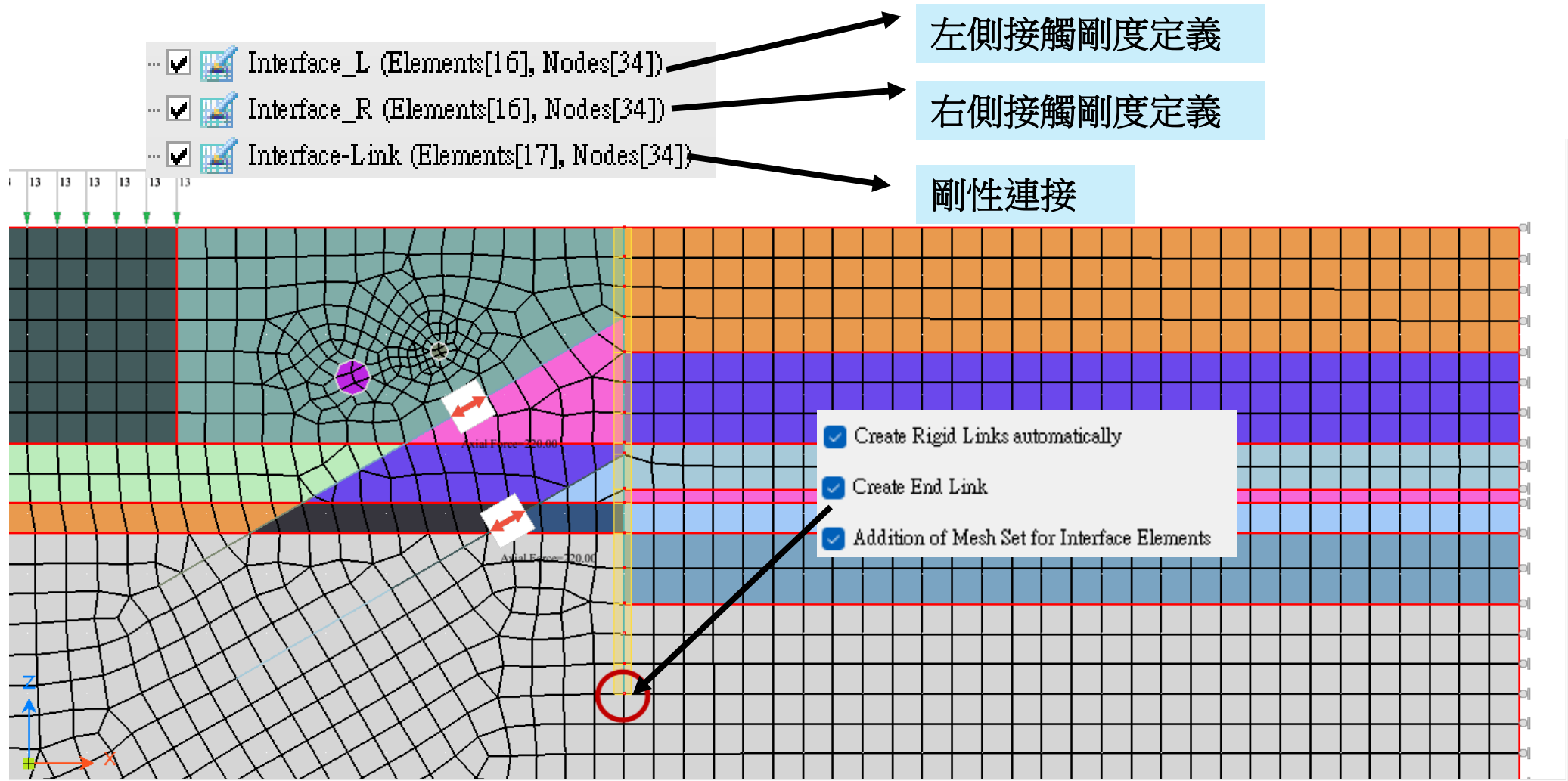

補充: 連續壁未相連元素

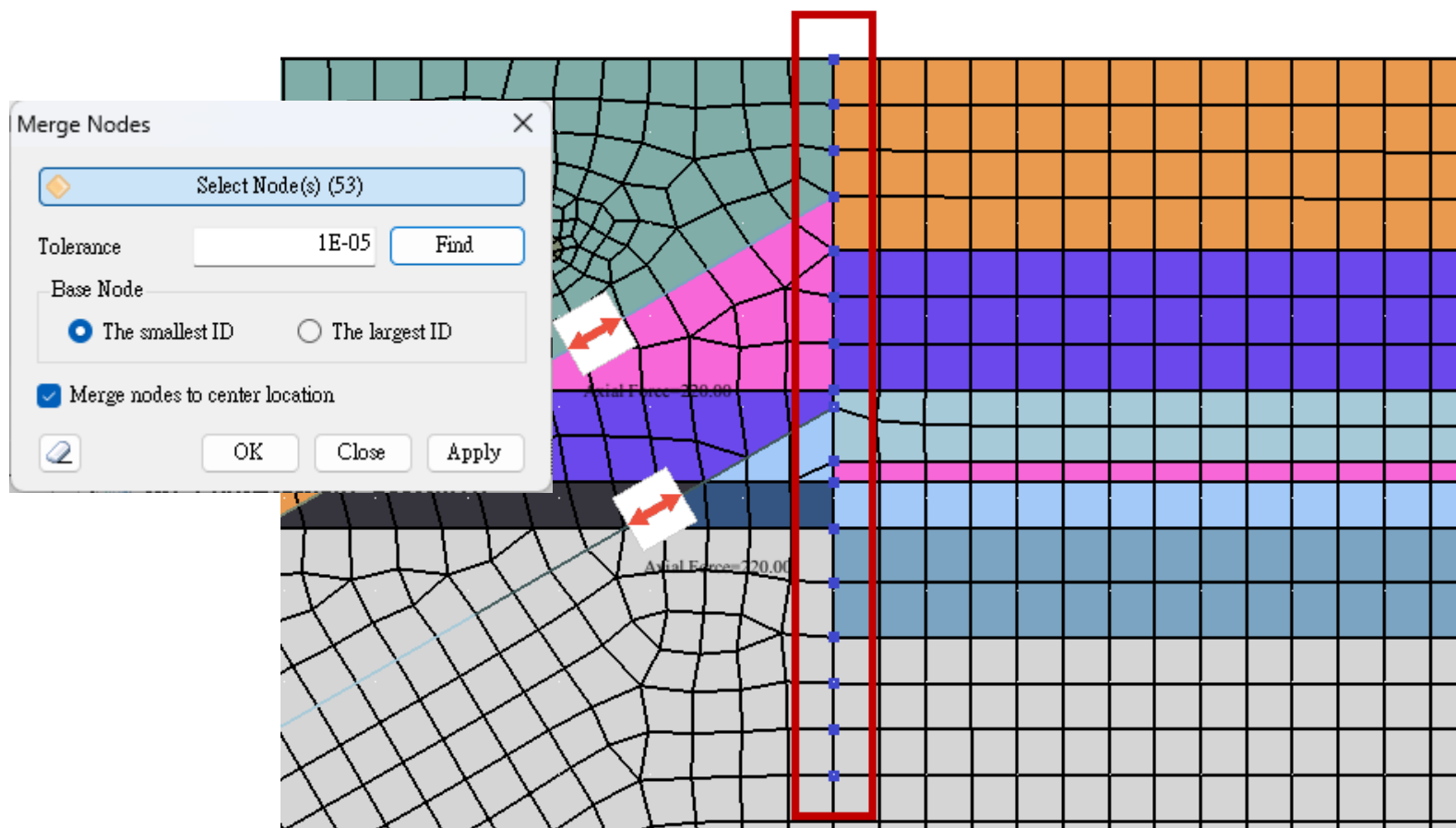
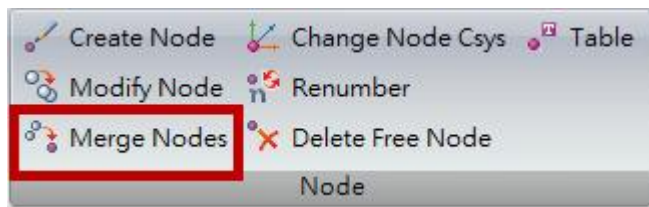

界面元素施工階段編輯

(Stage0. Initial and Stage2.Wall and Pressure)

Stage0. Initial

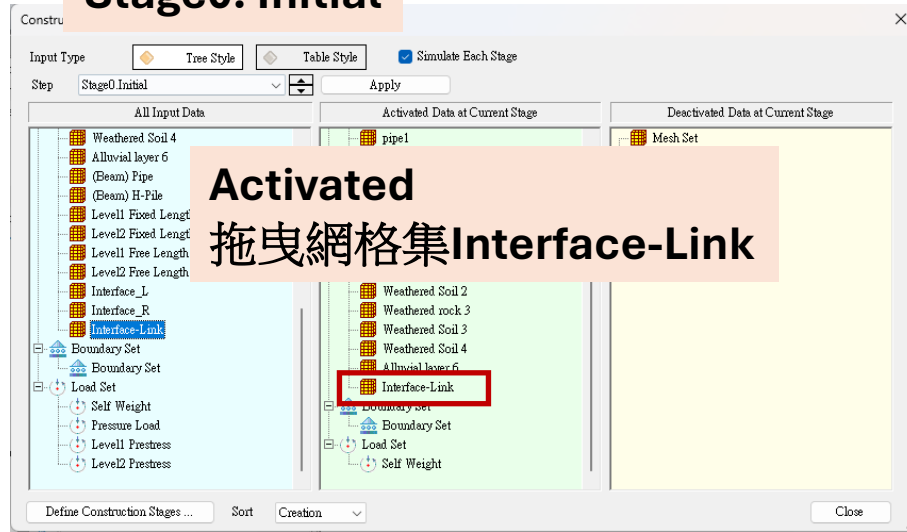

Stage2.Wall and Pressure

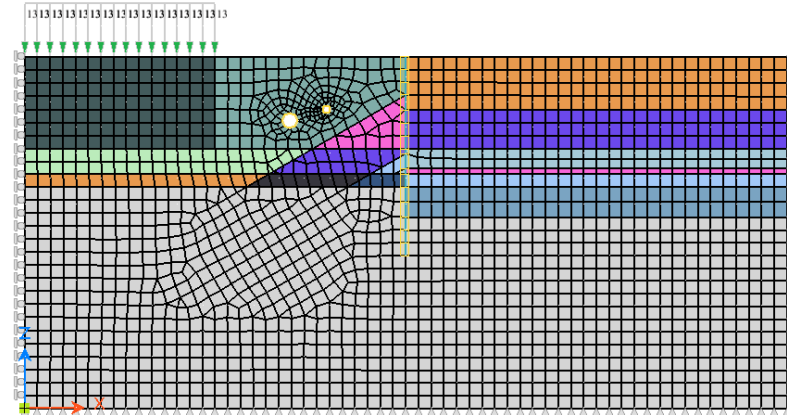
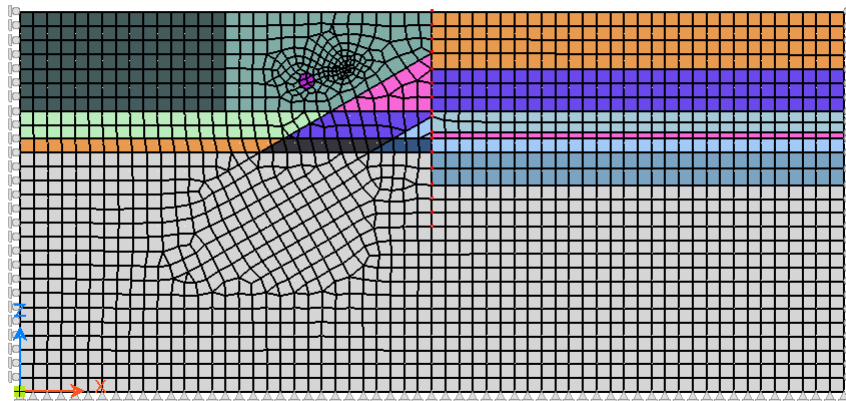
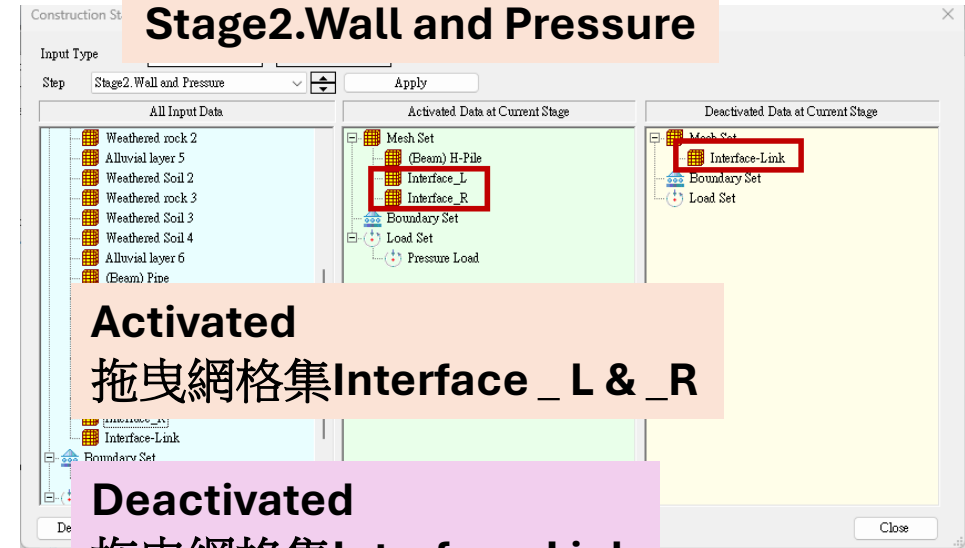

界面元素分析結果

依照施工階段定義順序
輸出6組結果

各類分析顯示定義

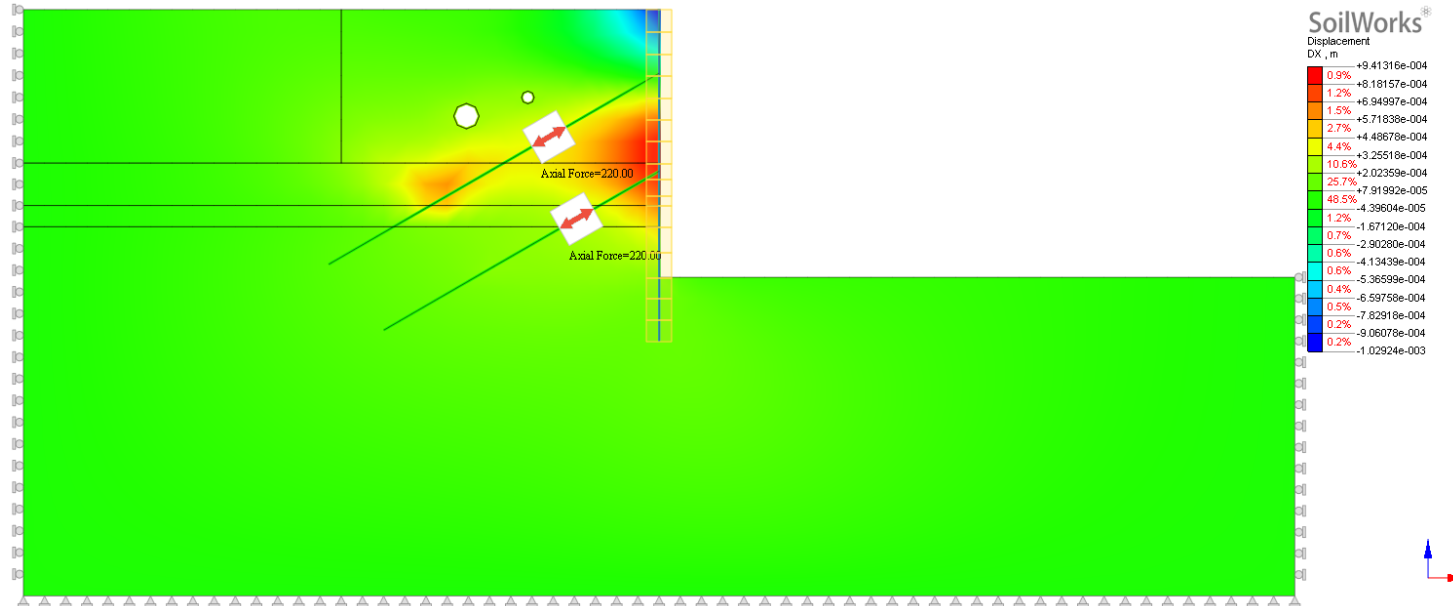
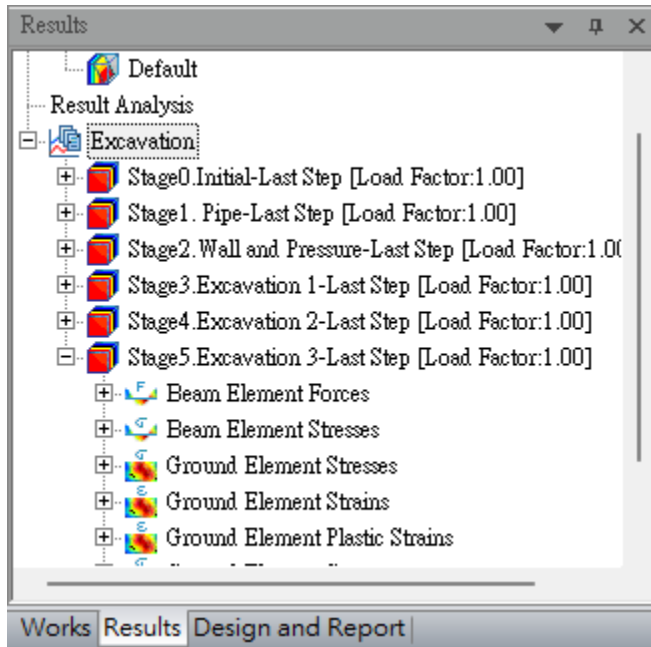
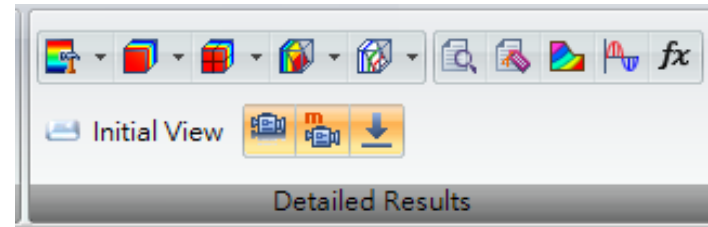
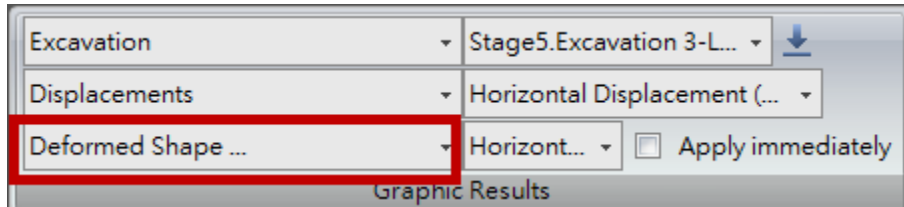

影片播放



檔案:Soilworks_標準教學系列1_大地分析_2_設定檔_Part3界面元素



Part4. 設計與報告



Design Options

Analysis I Design選單



Design Options 使用者自訂=>允許角位移

Tunnel Adjacent Structure

Allowable Displacement Management Standard User Defined

Allowable Angular Displacement (δ / L) 1 / 750.000

Allowable Settlement 0.025 m

Allowable Stress in Structure

Allowable Flexural / Axial Stress in Concrete Structure $f_{ca} = 0.400 \times f_{ck}$ (MPa)

Allowable Shear Stress in Concrete Structure $\tau_{ca} = 0.080 \times \sqrt{f_{ck}}$ (MPa)

Allowable Axial Stress in Steel Structures $f_{sa} = 0.500 \times f_y$ (MPa)

OK Cancel

User Defined

Bjerrum's Allowable Angular Distance (1963)
Skempton & MacDonald (1956)
Sower (1962)
Wilun & Starzewski (1975)
Boscardin & Cording (1989)



Adjacent Structure-1

Analysis I Design 選單

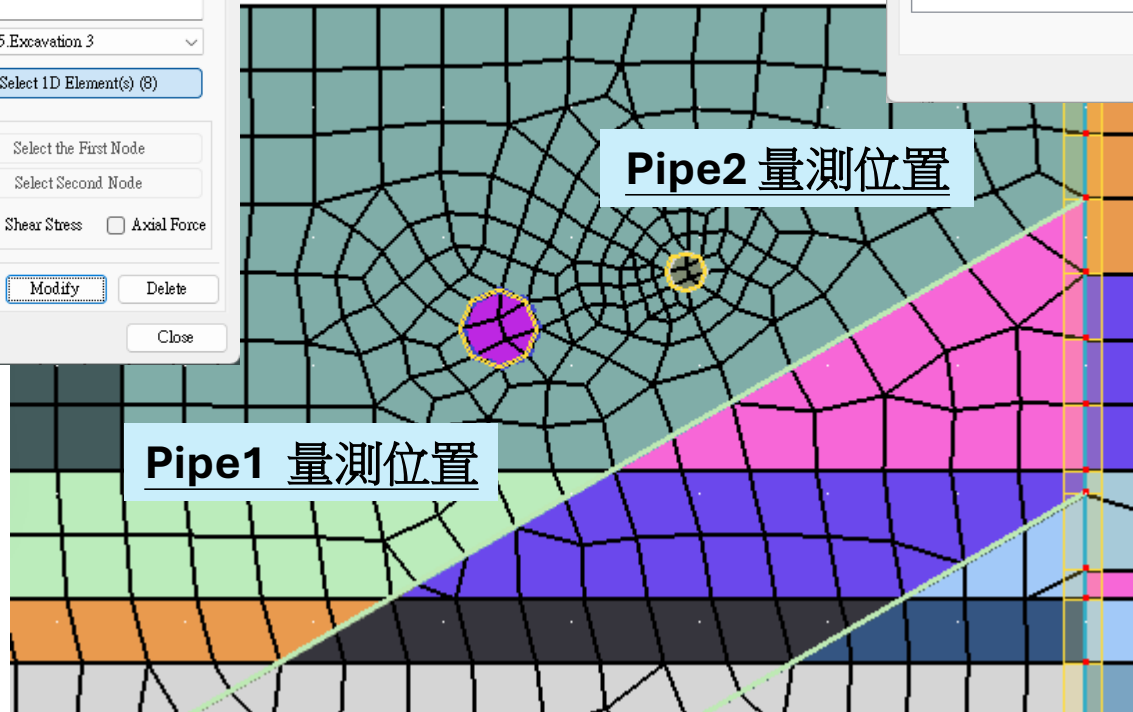
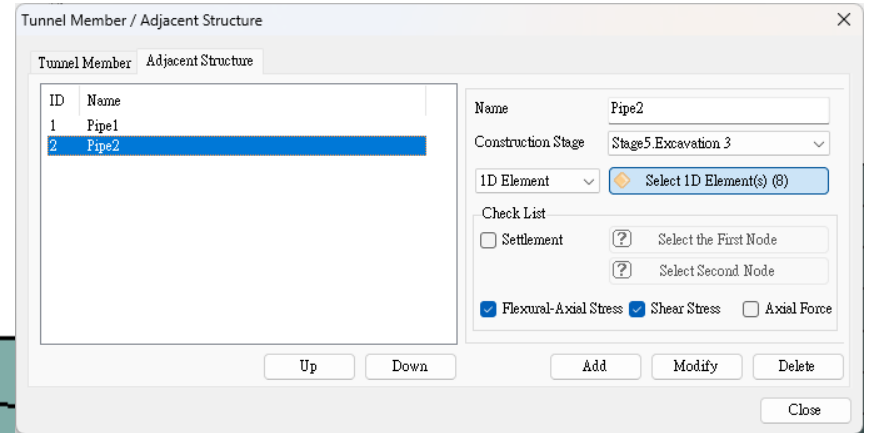
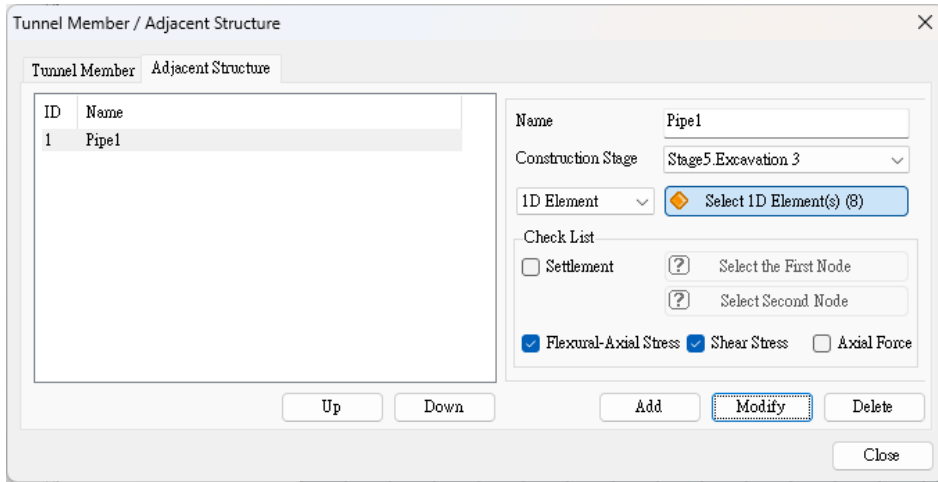

Report Generation

Analysis I Design 選單

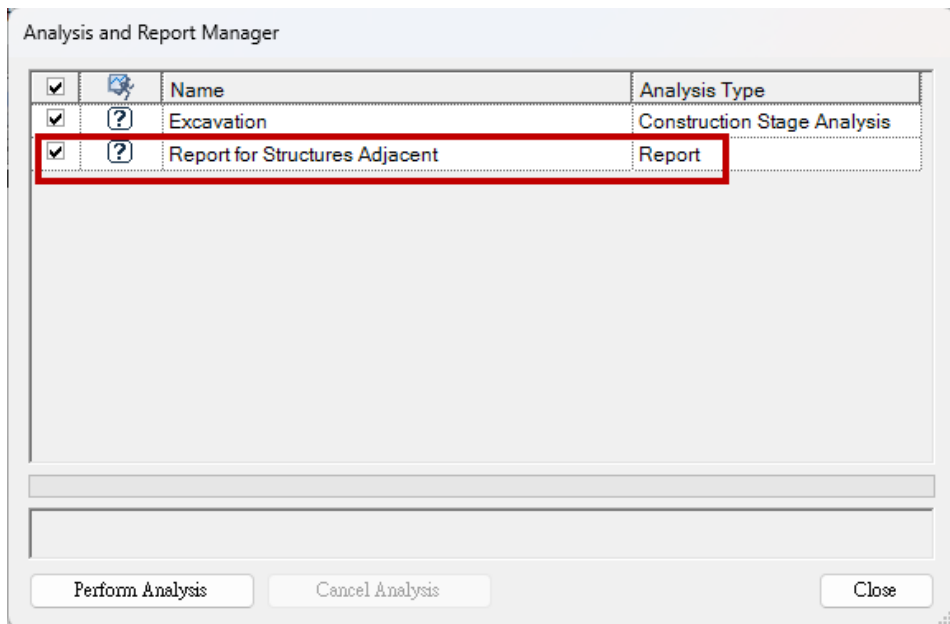
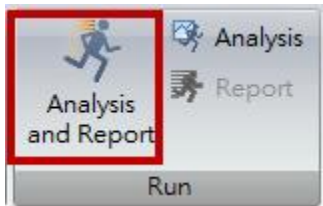

自動生成分析報告

- Soilworks_標準教學系列1_大地分析_2_設定檔_Part4設計與報告.stb
- Soilworks_標準教學系列1_大地分析_2_設定檔_Part3界面元素_STB_Excavation.OUT
- Soilworks_標準教學系列1_大地分析_2_設定檔_Part4設計與報告_STB_Excavation.OUT
- Soilworks_標準教學系列1_大地分析_2_設定檔_Part3界面元素.pvs
- Soilworks_標準教學系列1_大地分析_2_設定檔_Part4設計報告.pvs
- Soilworks_標準教學系列1_大地分析_2_設定檔_Part4設計與報告.pvs
- Soilworks_標準教學系列1_大地分析_2_設定檔_Part4設計與報告_GroundSettleReport.docx



Soilwoks_標準教學系列

無加筋邊坡穩定分析



邊坡穩定分析

填築邊坡、開挖邊坡的穩定分析是大地工程分析中常見的分析內容，邊坡的自重、孔隙水壓、附加載重、地震作用、波動水壓力載重對邊坡的穩定影響很大。

當自重和外力作用下，邊坡內部的剪應力大於邊坡岩土所具有的剪力強度時，邊坡將發生破壞。所以通過剪應力和剪力強度的分析來計算邊坡的穩定性的分析叫做邊坡穩定分析。

- **Soilworks /GTS NX**
 - Limit Equilibrium Method(LEM)-極限平衡法 2D
 - Stress Analysis Method (SAM)-應力分析法 2D
 - Strength Reduction Method (SRM)-強度折減法 2D/3D

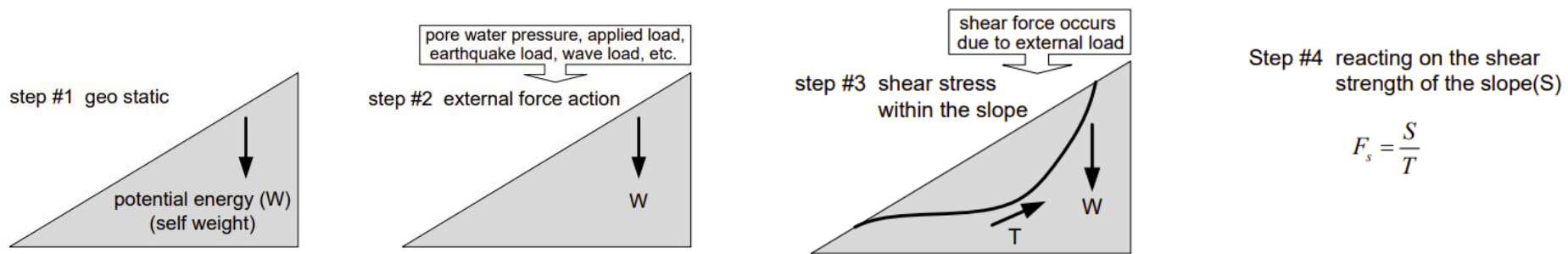

Reference

GTS NX/FEA NX/Soilworks Manual



Agenda

- **Part1.LEM無加筋邊坡穩定分析**
(Limit Equilibrium Method(LEM)-極限平衡法)
- **Part2.SRM無加筋邊坡穩定分析**
(Strength Reduction Method (SRM)-強度折減法)



Part1.LEM無加筋邊坡穩定分析

(Limit Equilibrium Method(LEM)-極限平衡法)



Par1. LEM邊坡開挖

Stage0. Initial

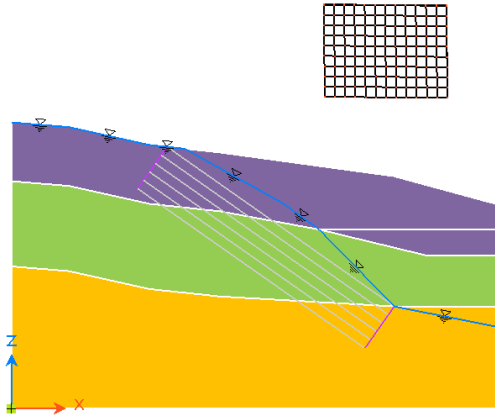

Stage1. Excavation 1

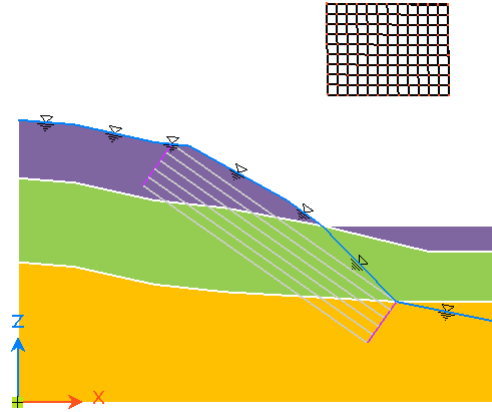

Stage2. Excavation 2

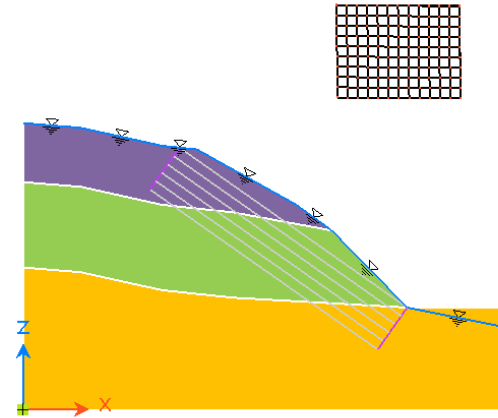

Stage3. Excavation 3

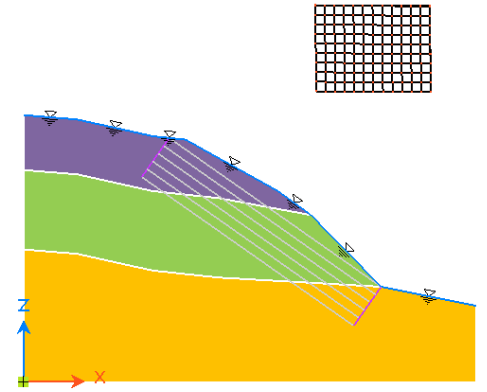

Limit Equilibrium Method(LEM)

(極限平衡法)

極限平衡法(LEM)，計算滑動面位置相對於地表質量的力和力矩的平衡。基於此觀念，沿著假設的直線、圓弧或不規則的滑動面符合莫爾-庫侖破壞準則，計算在滑動面破壞時刻時的穩定性，透過兩個主要材料參數評估的破壞表面內聚力(c)和內摩擦角(ϕ)。

The simplified Bishop method

由於其簡單性和相對精確度，在各種切片方法中應用最為廣泛。安全係數(F)需要透過迭代過程和試誤法來計算。

$$F = \frac{1}{\sum W \sin \alpha} \sum \left[\{c' l \cos \alpha + (W - ul \cos \alpha) \tan \phi'\} \left\{ \frac{1}{m_\alpha} \right\} \right]$$

$$\text{where, } m_\alpha = \cos \alpha \left(1 + \frac{\tan \alpha \tan \phi}{F} \right)$$

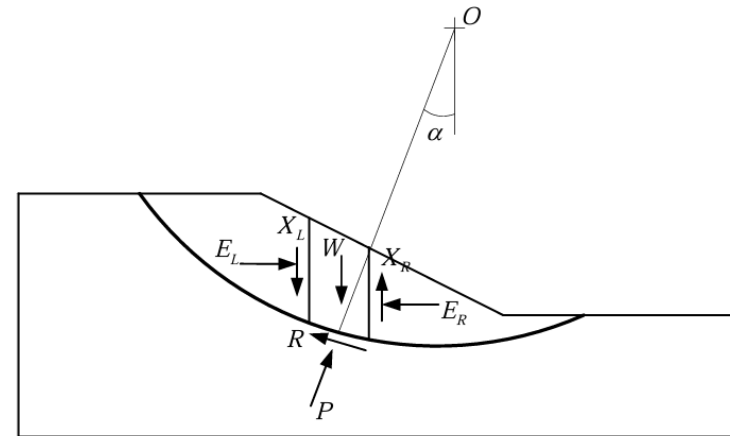
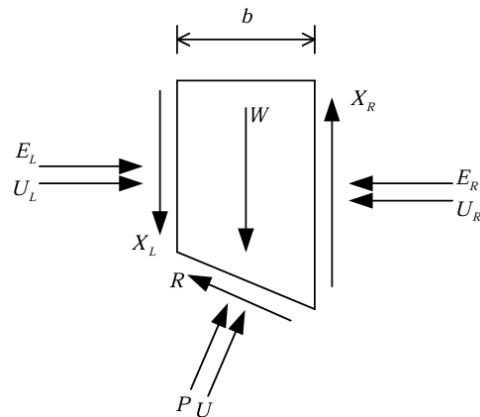

Reference

GTS NX/FEA NX/Soilworks Manual



Arc Failure Surface

(弧型破壞面)

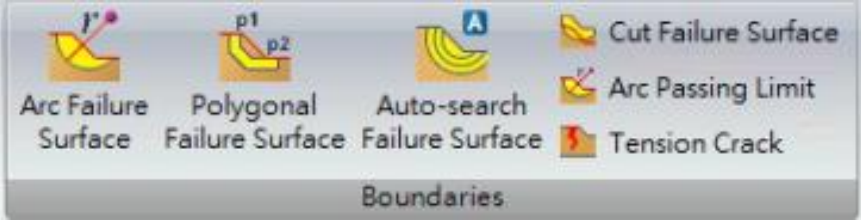

若最小安全係數對應的圓弧中心位於該區域的外圍，則必須重新定位圓弧中心區域，使圓弧最小安全係數對應的中心落在圓弧中心區域的中間。

預期安全係數最小的位置定義圓弧中心區域。

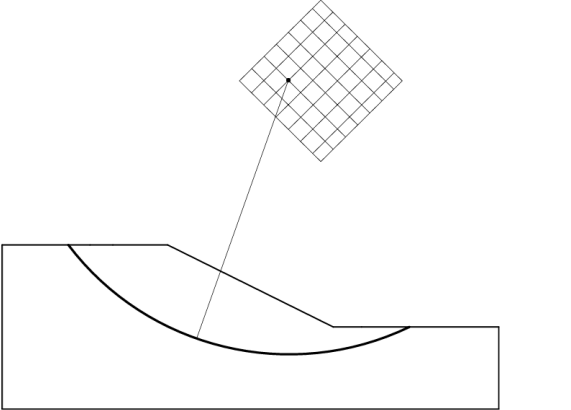

Arc Tangent Method

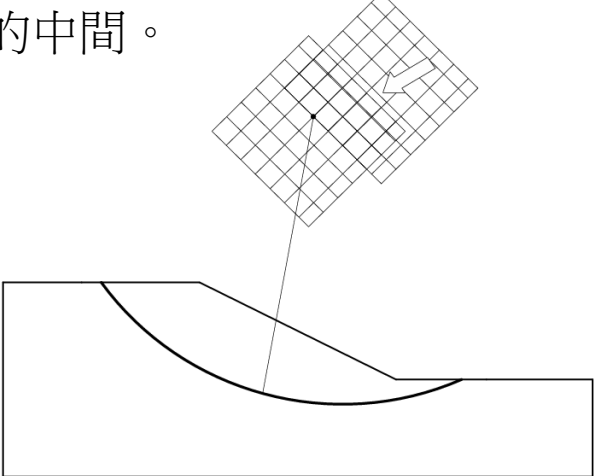

Arc Radius-Length Method

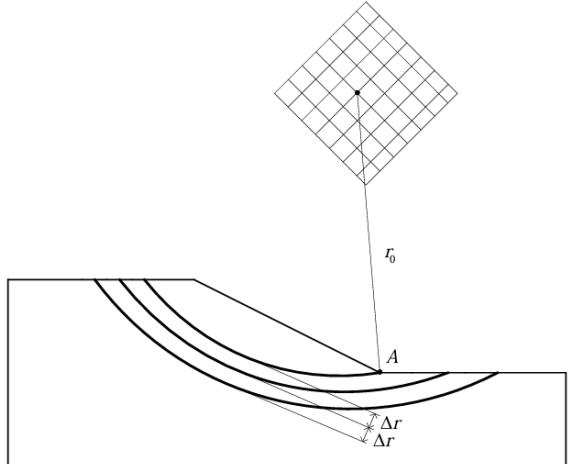
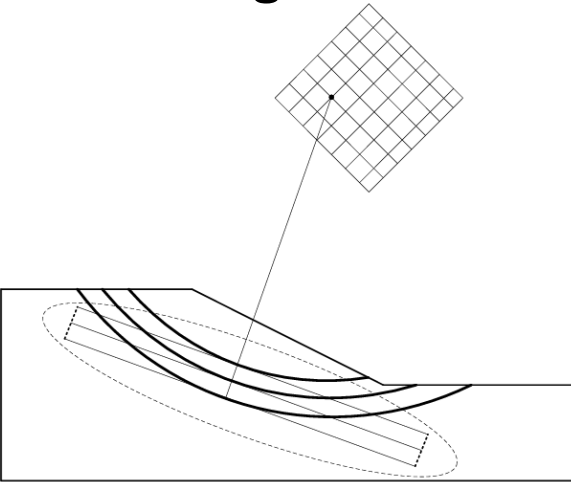

邊坡(Slope)模組



選擇邊坡(Slope)模組

Limit Equilibrium Method(LEM)-極限平衡法

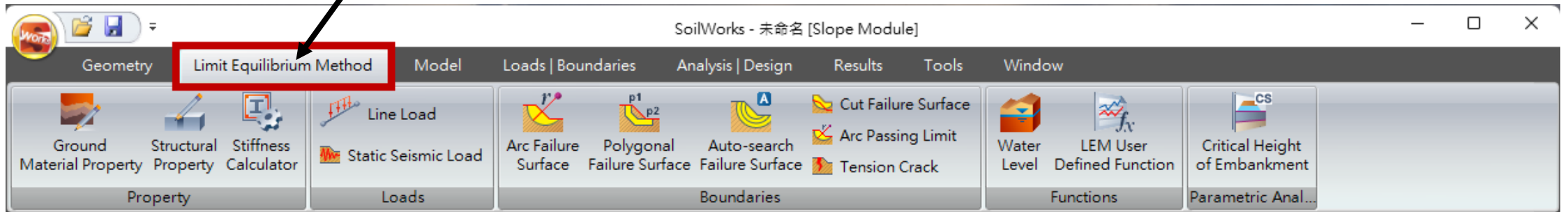

單位切換

The screenshot displays the MIDAS Gen software interface. The main window shows a project tree on the left and a central workspace. Two dialog boxes are open:

- Define Initial Parameters:** A dialog box with a title bar "Define Initial Parameters". It has tabs for "Unit System", "Force", "Length", "m", and "Time", "sec". Under "Unit System", "SI", "CGS", "FPS", and "User Defined ..." are listed. The "Initial Parameters" section includes:
 - Gravitational Acceleration: 9.807 m/sec²
 - Unit Weight of Water: 9.807 kN/m³
 - Initial Temperature: 0.000 [T]Buttons for "Project Information..." and "OK" are at the bottom.
- Unit settings:** A dialog box titled "Unit settings" with a close button (X). It has three columns:
 - Force Unit [F]:** Radio buttons for kgf, tonf, N, **kN** (selected), lbf, and kips.
 - Length Unit [L]:** Radio buttons for **m** (selected), cm, mm, ft, and inch.
 - Time Unit [T]:** Radio buttons for **sec** (selected), min, hour, and day.Buttons for "Reset", "OK", and "Cancel" are at the bottom.

A 3D coordinate system with X, Y, and Z axes is visible in the workspace.



DWG模型匯入

Import>CAD File

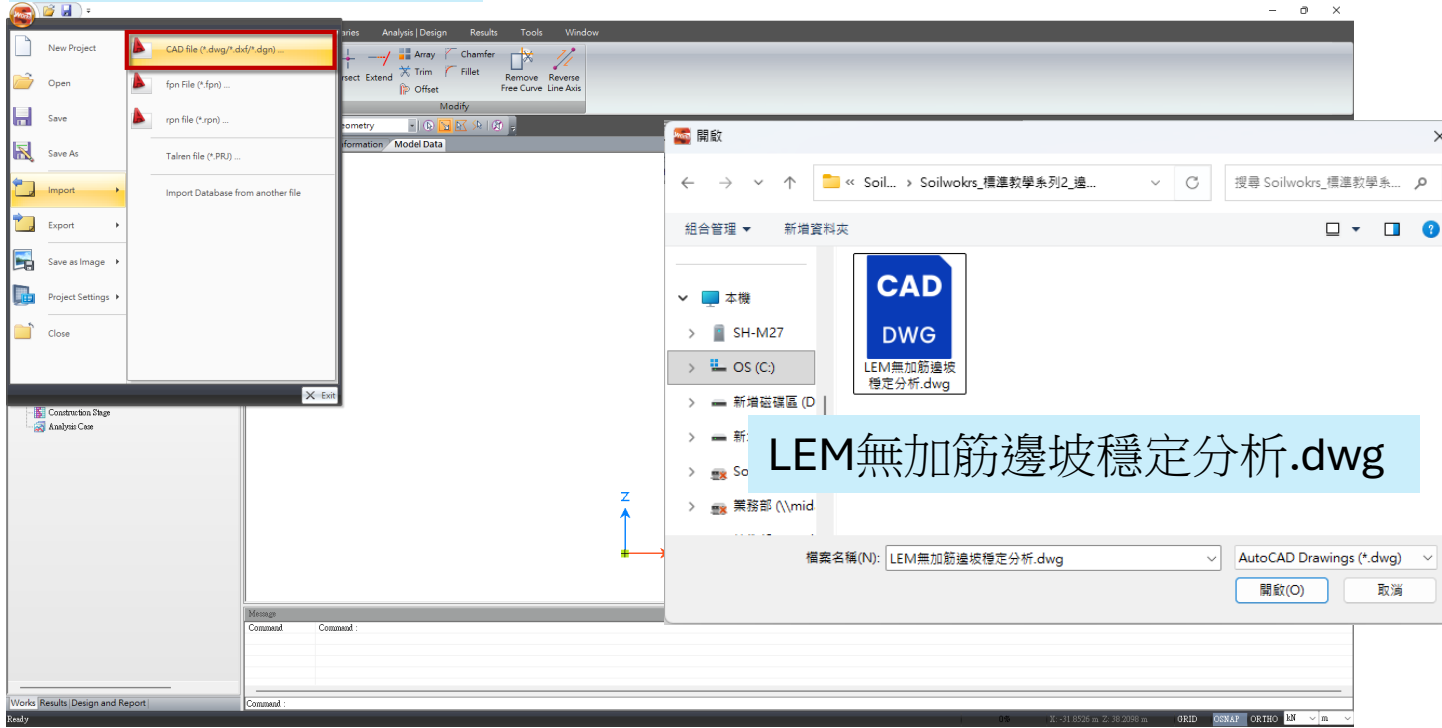

匯入後線特徵模型

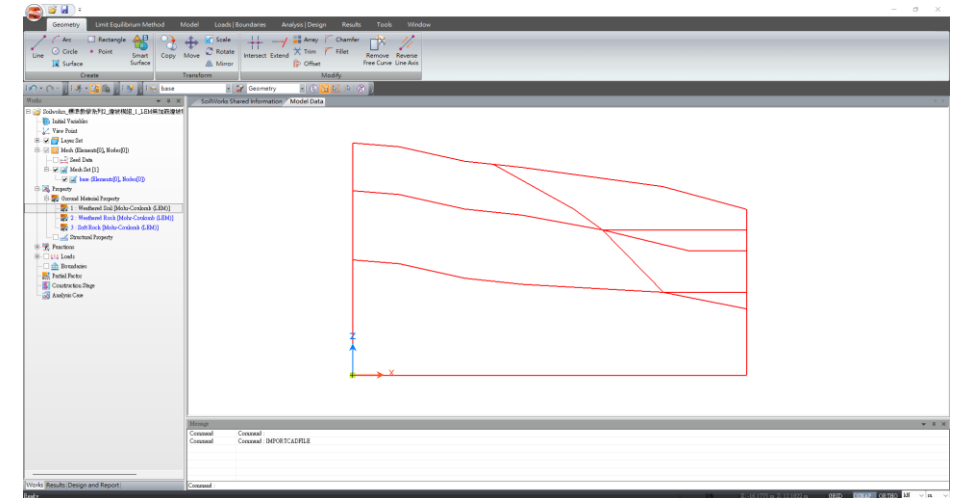

土壤材料屬性(Soilworks材料庫)

Limit Equilibrium Method

選取 1.1schist#1 類別



Define Ground Material Property

Data

ID	Name
1	

General

ID: 1 Name: []

Model Type: Mohr-Coulomb

General Parameters

Modulus of Elasticity (E)	20000000	kN/m ²
Poisson's Ratio (ν)	0.3	
Temperature Coeff. (α)	1E-06	
Unit Weight (γ)	20	kN/m ³
Saturated Unit Weight	21	kN/m ³
Cohesion (c)	30	kN/m ²
Internal Friction Angle (Φ)	36	[deg]
Earth Pressure Coeff. (K ₀)	1	
Draining Condition	Drained	

Additional Parameters

Variation in Modulus of Elasticity	0	kN/m ²
Variation in Cohesion	0	kN/m ²
Reference Height	0	m
<input type="checkbox"/> Dilatancy Angle (ψ)	36	[deg]
<input type="checkbox"/> Tensile Strength	2000	kN/m ²

Database ... Material Statistic Add Modify Delete Close

Ground Material Database

Database: 1.1 Schist#1

No.	Soil Type	Modulus of Elasticity (kN/m ²)	Unit Weight (kN/m ³)	Saturated Unit Weight (kN/m ³)	Poisson's Ratio	Cohesion (kN/m ²)	Internal Friction Angle	Select
1	Landfill Layer	13000	18	19	0.33	0	27	<input type="checkbox"/>
2	Alluvial Layer	8000	17	18	0.35	15	20	<input type="checkbox"/>
3	Weathered Soil	36500	18.5	19.5	0.33	17.5	31	<input checked="" type="checkbox"/>
4	Weathered Ro	150000	21	22	0.3	50	33	<input checked="" type="checkbox"/>
5	Soft Rock	1850000	24	25	0.28	180	35.5	<input checked="" type="checkbox"/>
6	Hard Rock	17500000	26	27	0.23	1750	40.5	<input type="checkbox"/>

選取 No3~No5

材料切換成Mohr-Coulomb(LEM)

Model Type: Mohr-Coulomb (LEM)

Assign新增材料

完成LEM土壤材料新增

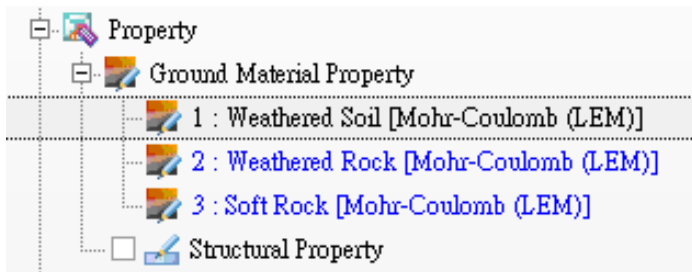

Soilworks材料庫



Geometry 選單>Smart Surface

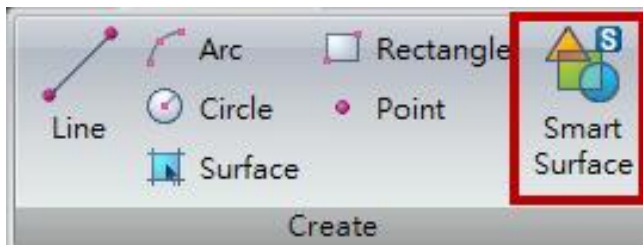

自動生成面特徵

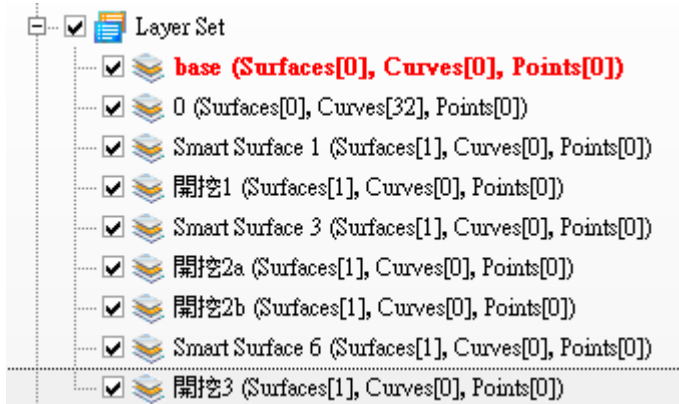

編輯名稱(幾何特徵)

面特徵建立

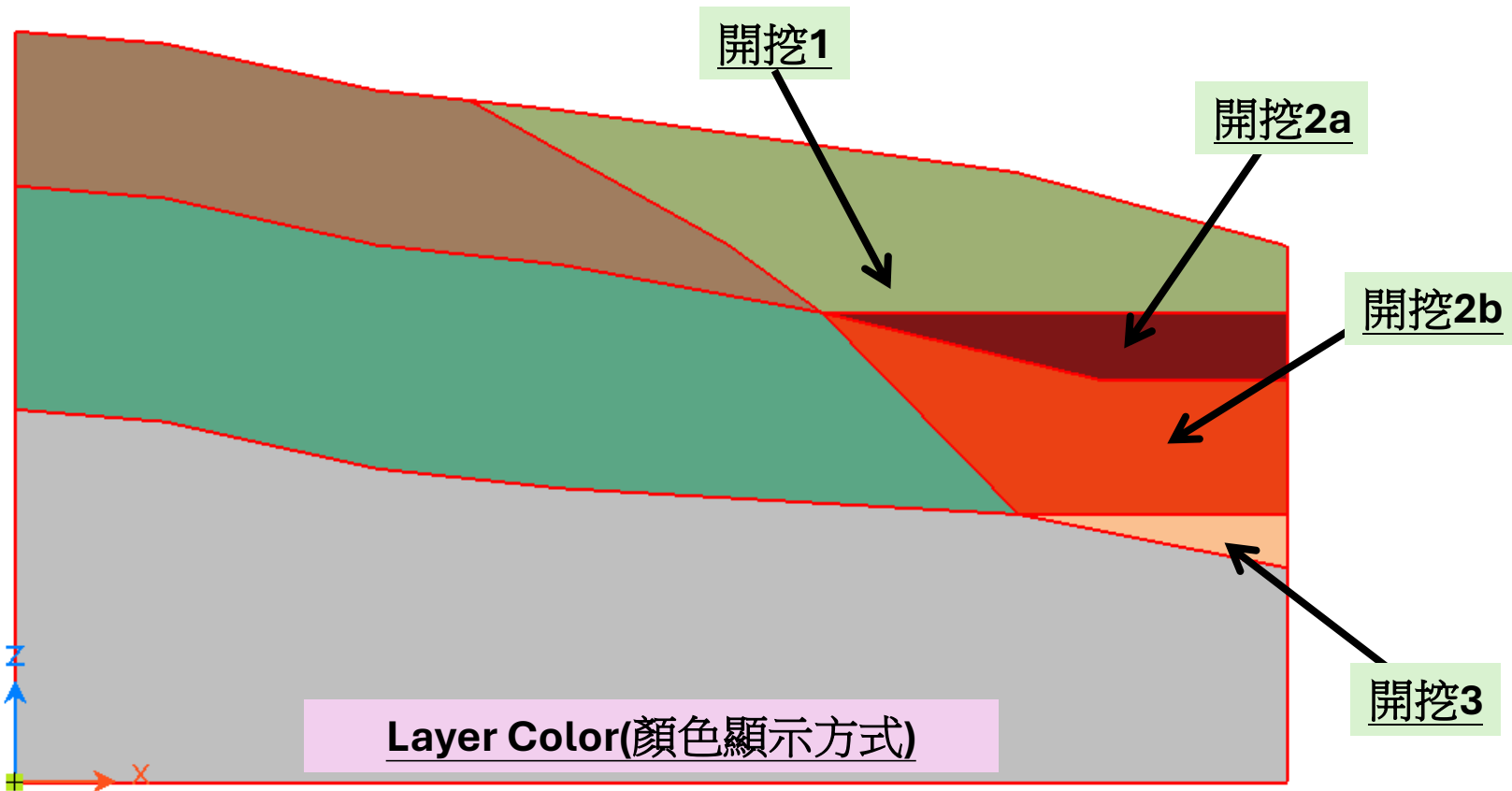

顏色顯示(補充)

自訂屬性顏色

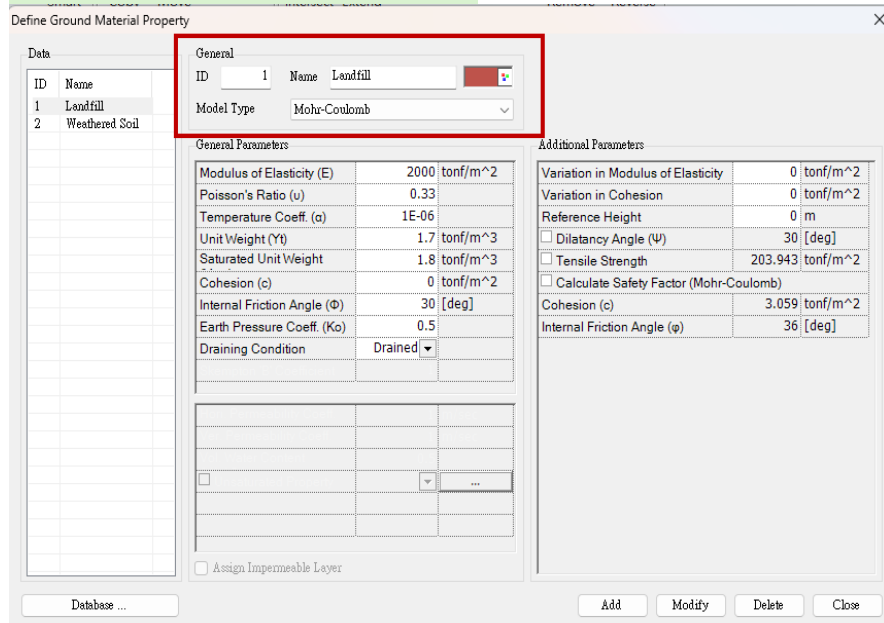

Display Setting顯示設定

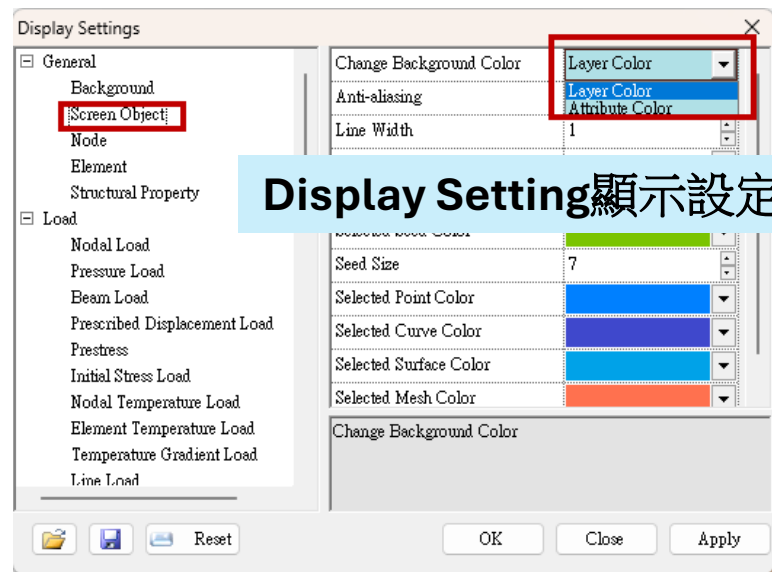

Display Setting顯示設定



Attribute Color (顏色顯示方式)
(Property Color)

土壤材料屬性指定

Select Filter 切換到 Surface

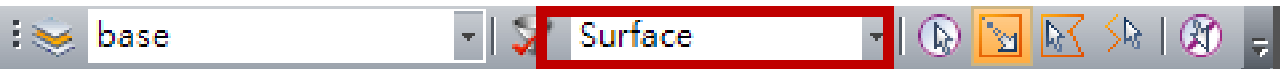

框選 Weathered Soil 分布區域特徵

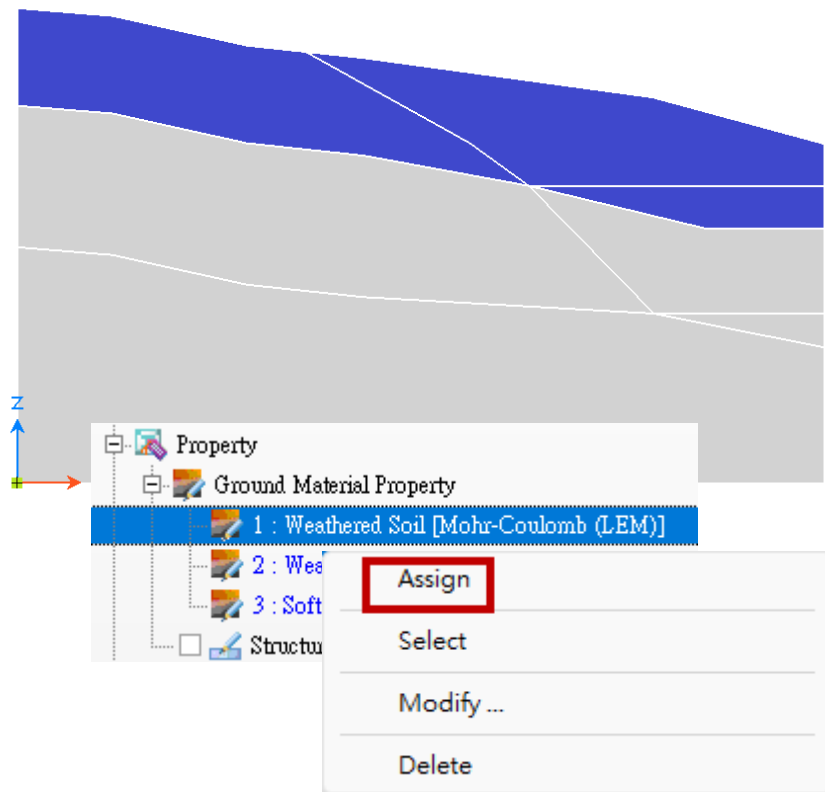

框選 Weathered Rock 分布區域特徵

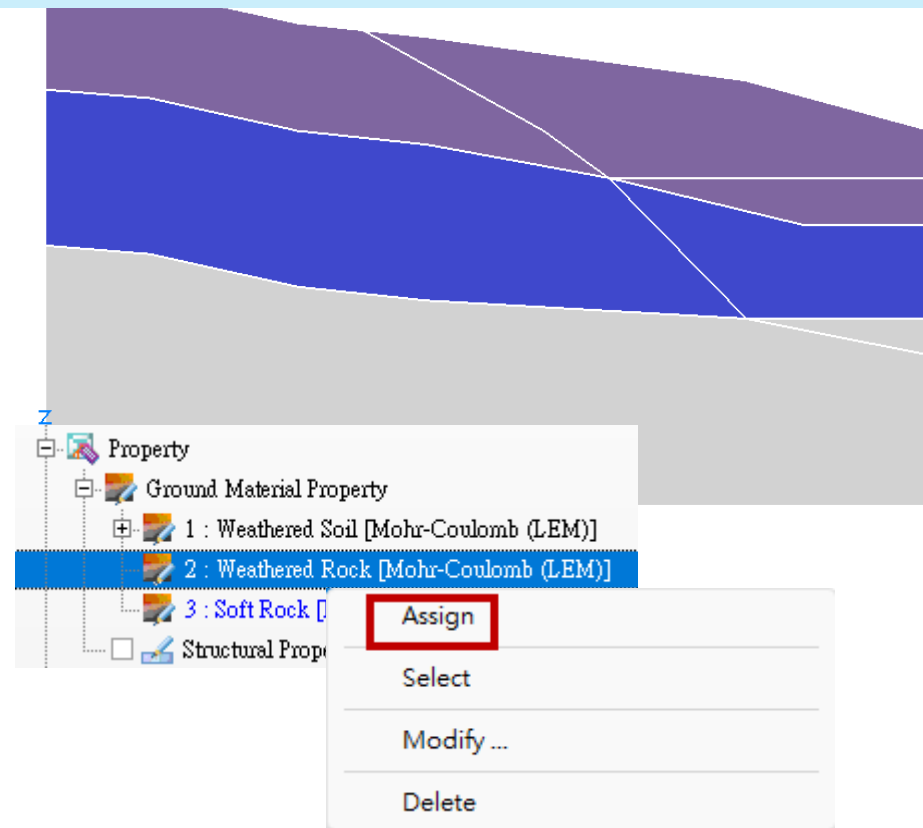

土壤材料屬性指定

Select Filter 切換到 Surface

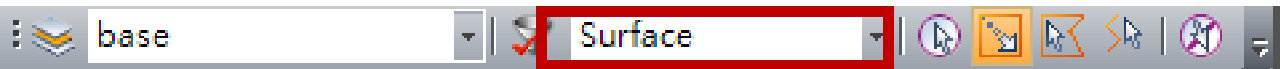

框選 Soft Rock 分布區域特徵

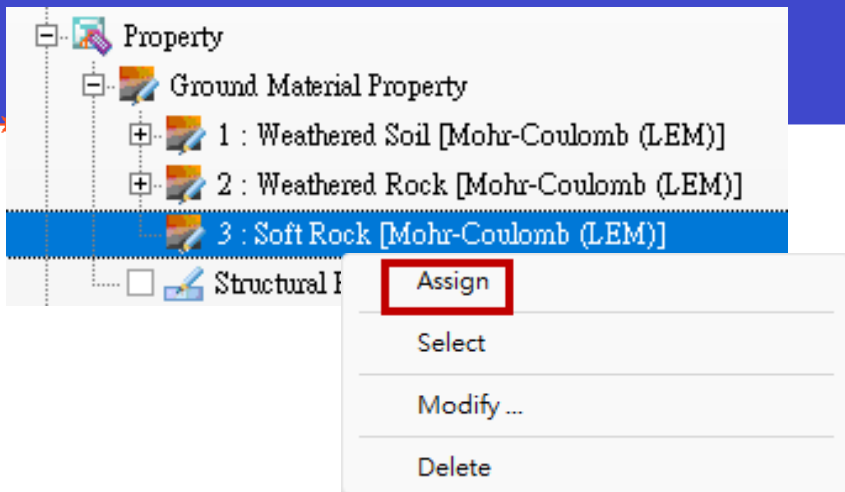
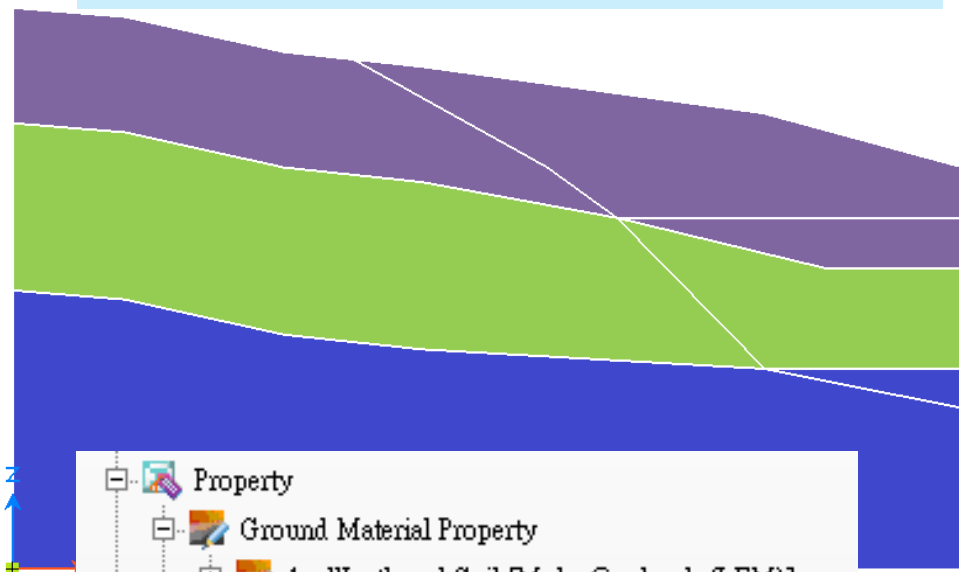

Ground Material Property 模型樹顯示指定特徵數量

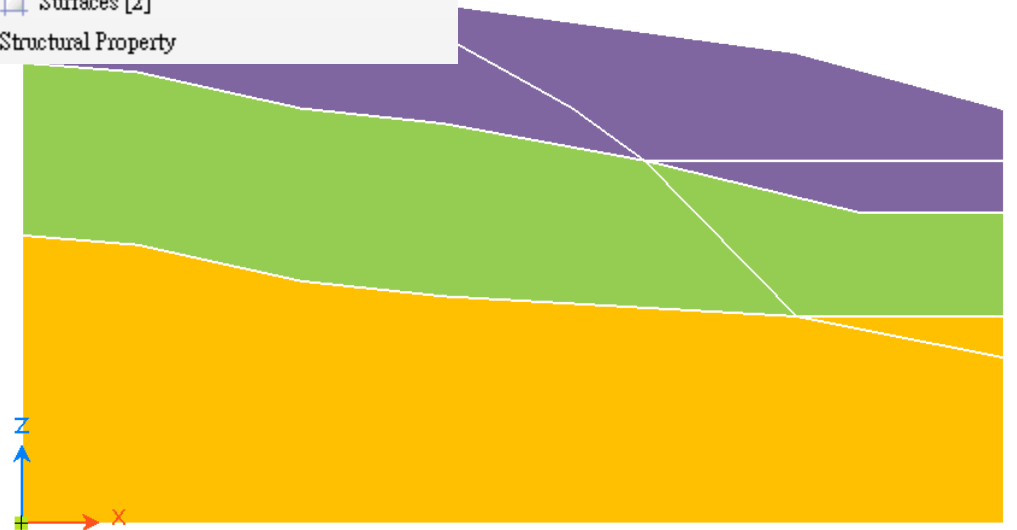
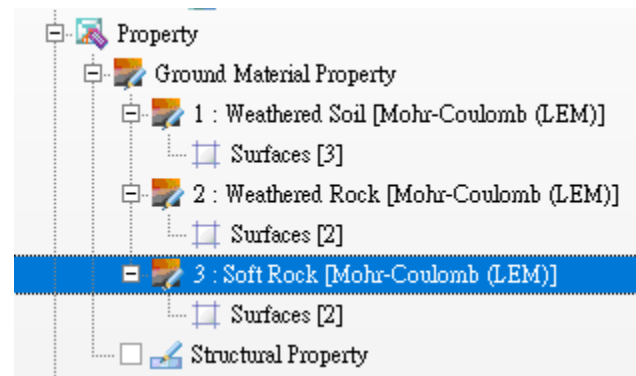

水位線

Limit Equilibrium Method

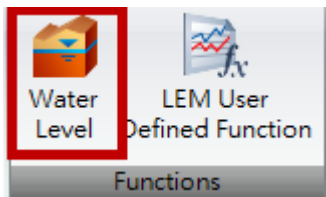

Water Level

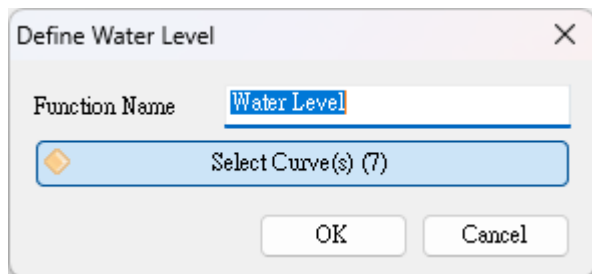

Select Filter 切換到 Curve

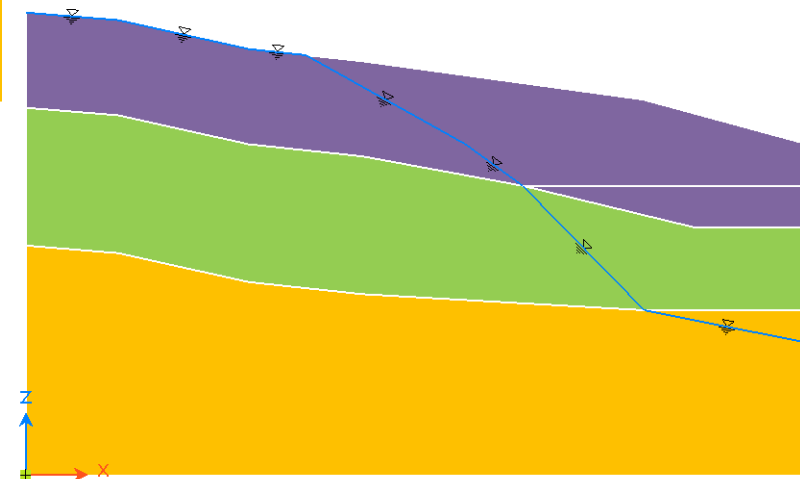
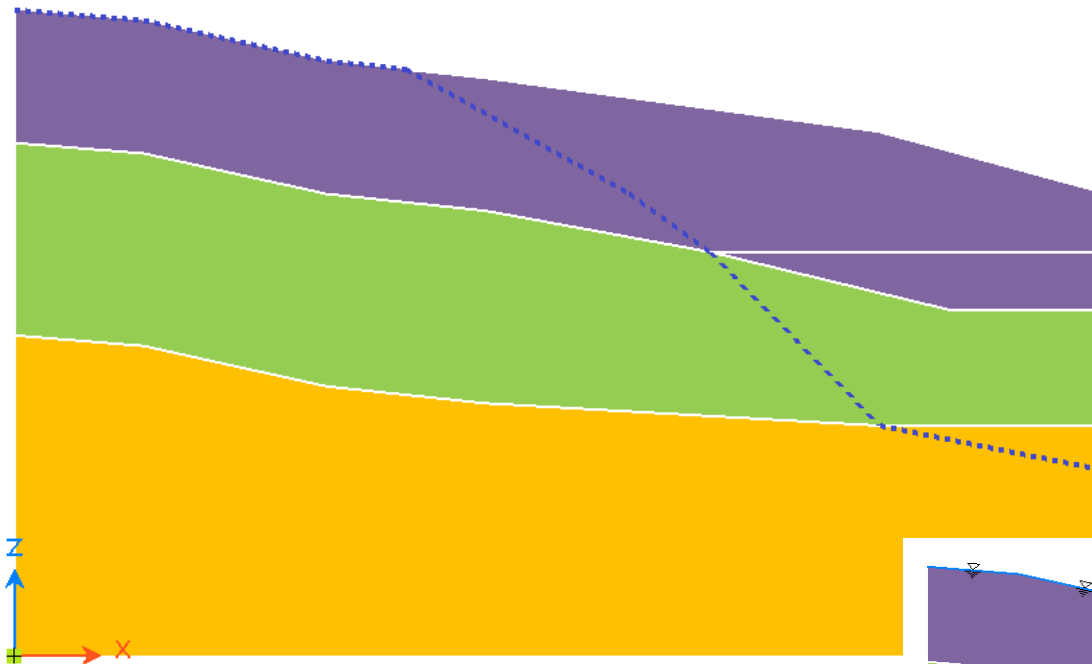
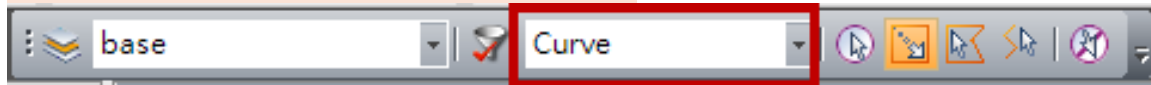

破壞面說明-1

(Failure Surface)

定位原則

網格中心盡量靠近預期的
「最小安全係數」圓心。

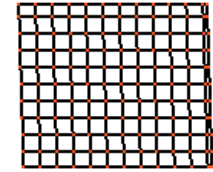
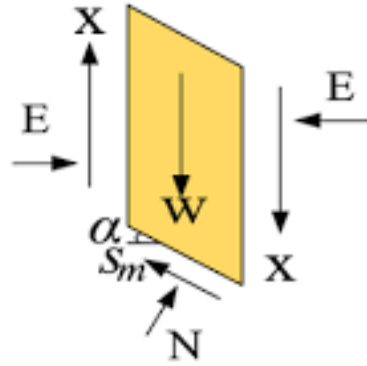
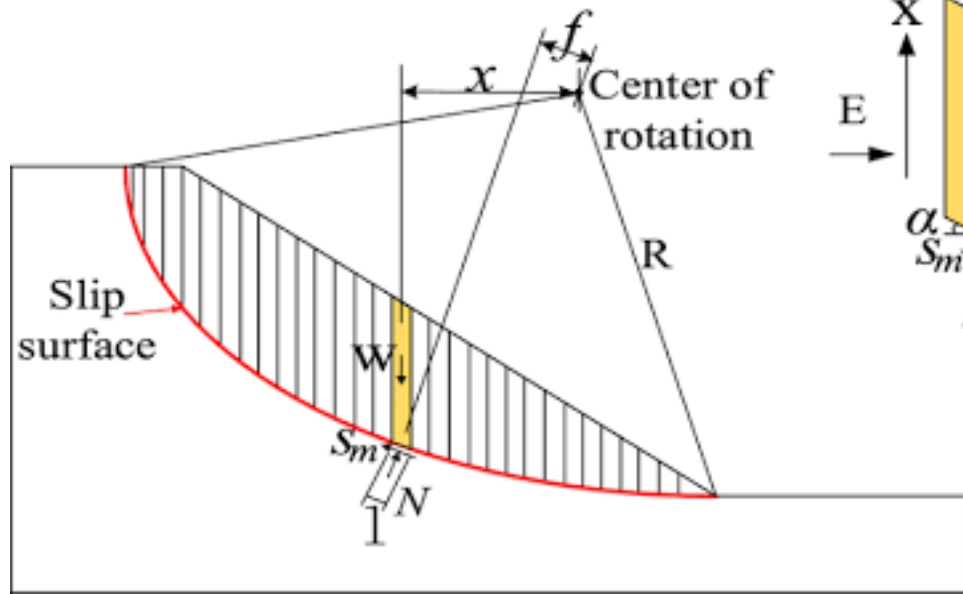

Grid Data

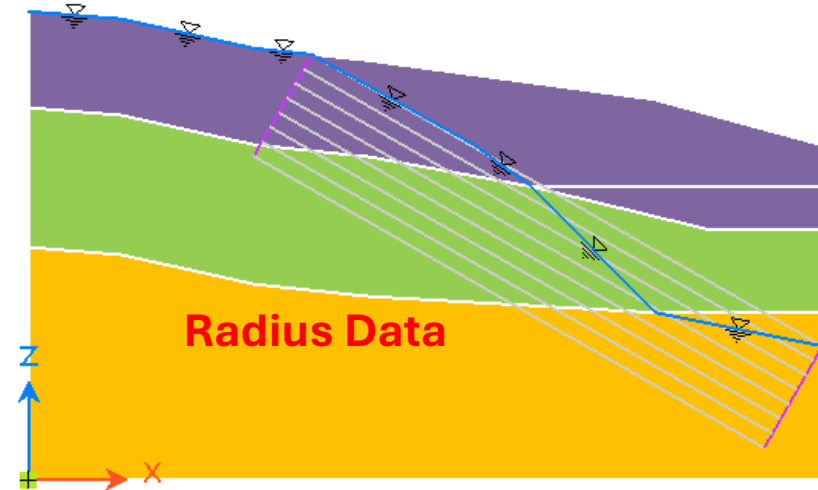

定義範圍

潛在破壞面的搜尋範圍，程式將以網格點為圓心，建立一系列圓弧破壞面並計算安全係數。



Reference

LEM 切片法受力與破壞面. 資料來源：ResearchGate

破壞面說明-2

(Failure Surface)

結果檢核

分析完成後請務必檢查！若發現產生最小安全係數的圓心落在網格邊界或外側，代表目前的範圍可能未涵蓋到真正的臨界滑動面。

重新調整

若發生上述邊界狀況，請重新指定網格資料，擴大或平移搜尋範圍後再次分析。

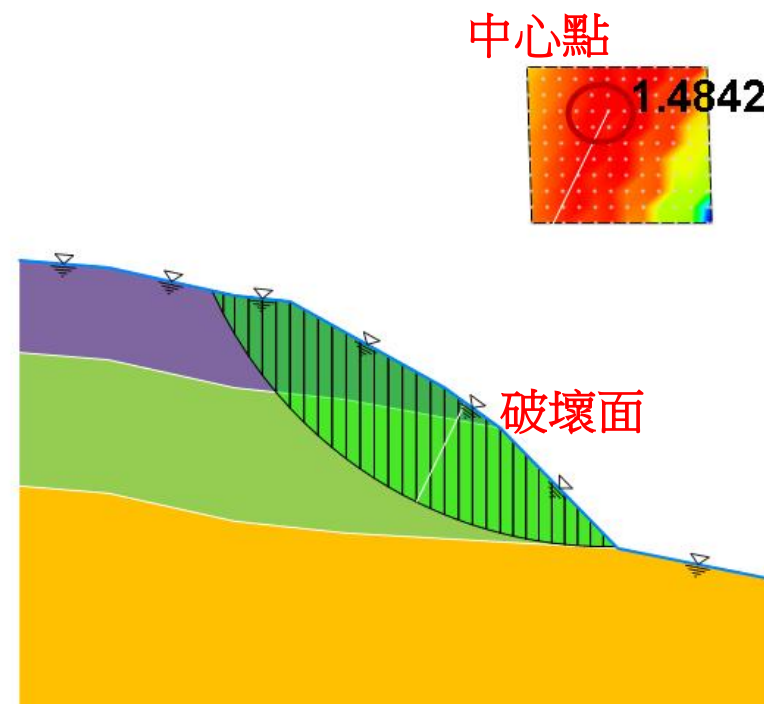
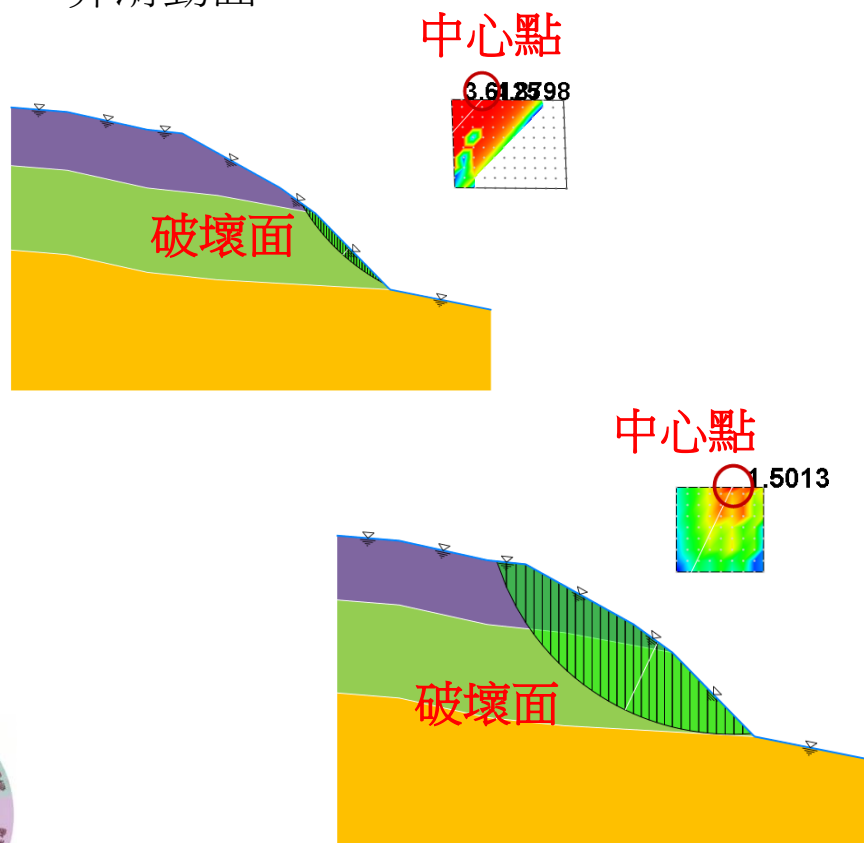

Limit Equilibrium Method

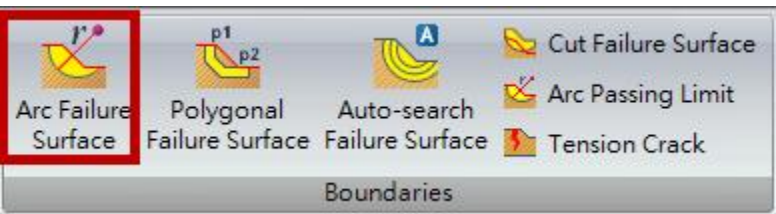

開挖1-破壞面-1 (Arc Failure Surface-Grid Data)

自訂Boundary Set名稱:LEM開挖1

圓弧中心區域定義

Grid Data

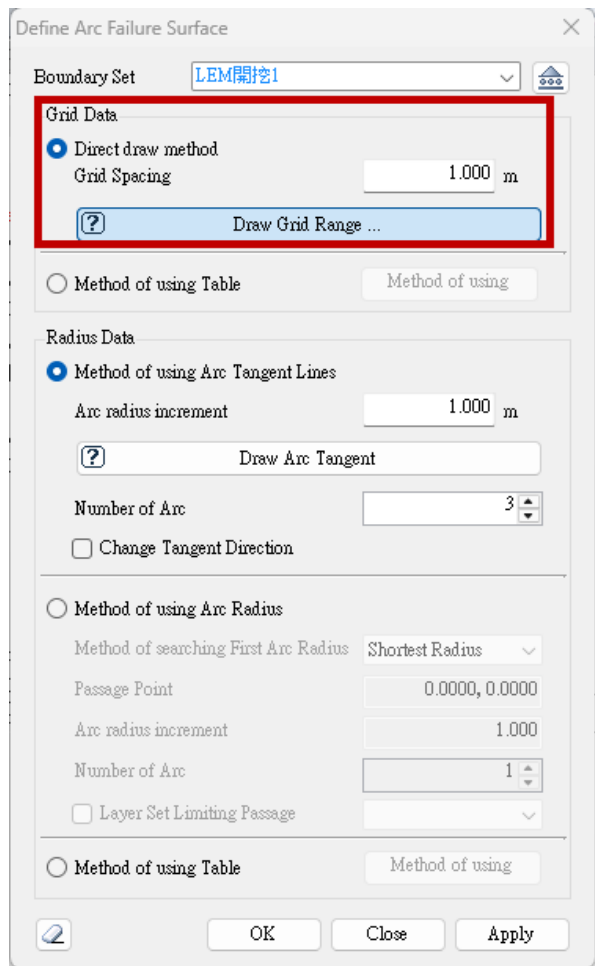

Poin1

Poin2

Poin3

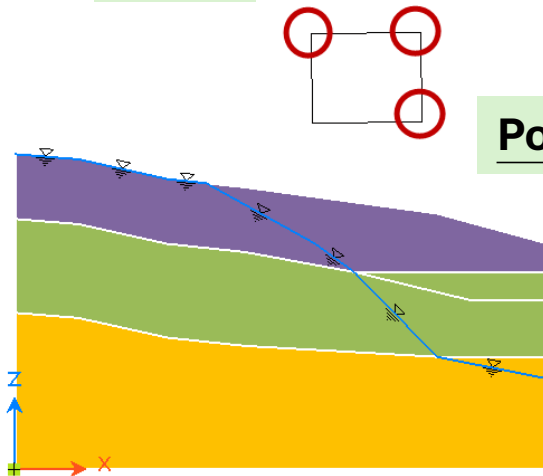

預設節點間隔 (1m)

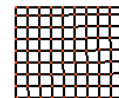

Draw Grid Range
依照順序空間點選Point1~Point3

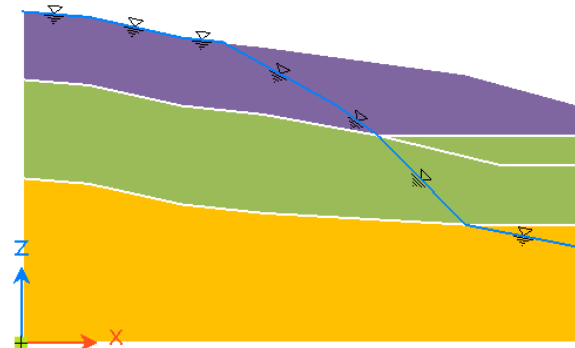

開挖1-破壞面-2

(Arc Failure Surface-Radius Data)

破壞面區域定義

預設採Arc Tangent Method

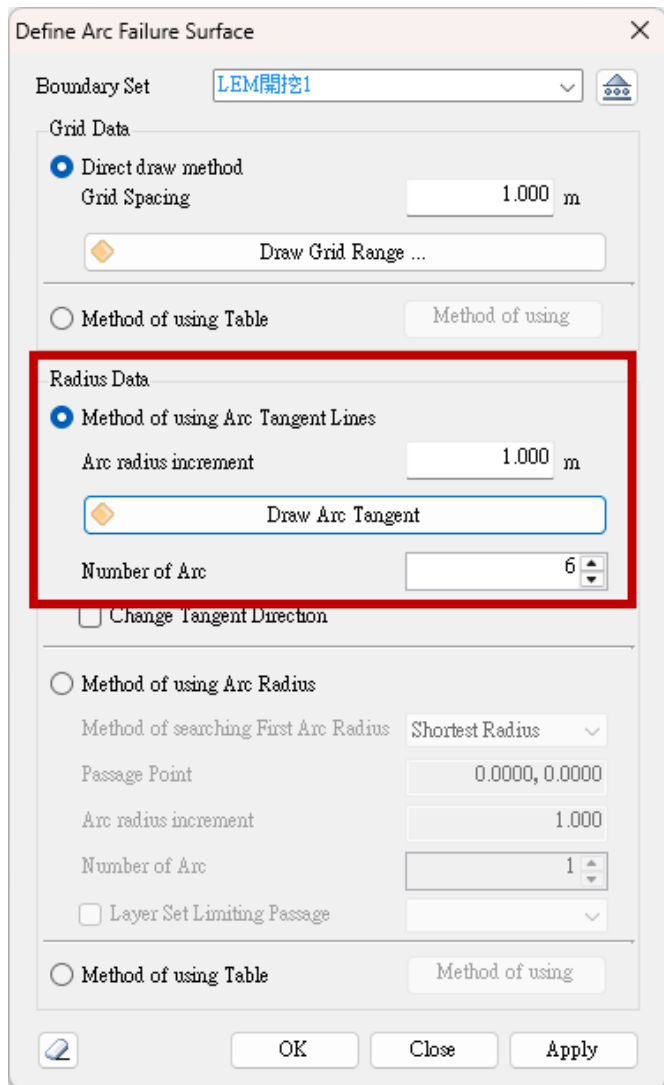
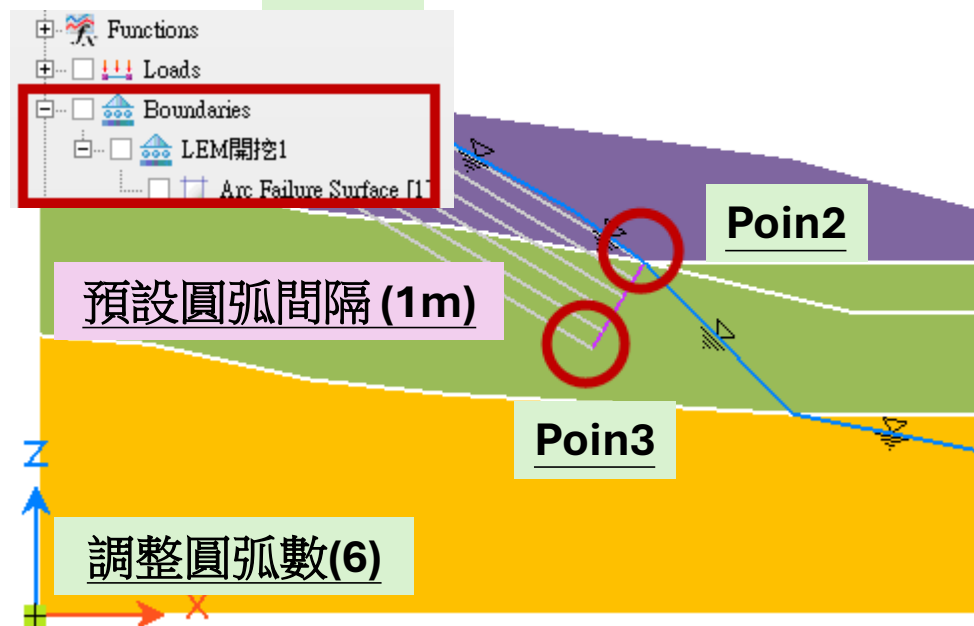
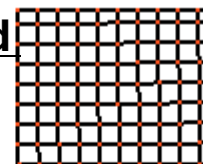

Radius Data



Limit Equilibrium Method

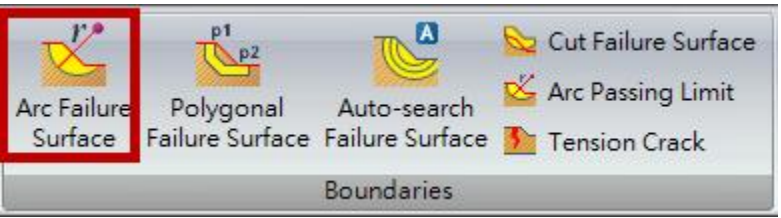

開挖2-破壞面-1 (Arc Failure Surface-Grid Data)

自訂Boundary Set名稱:LEM開挖2

隱藏LEM開挖1

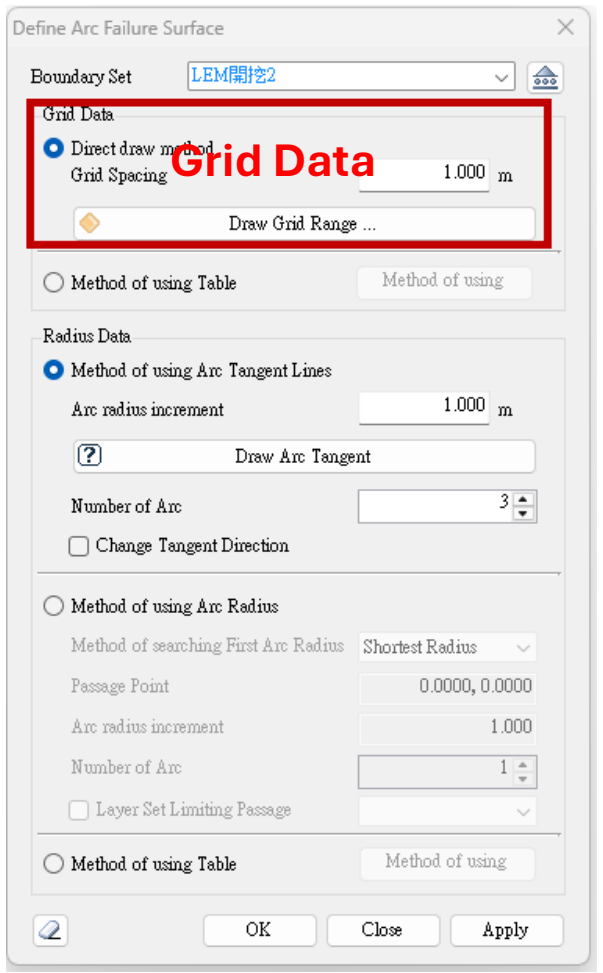

圓弧中心區域定義

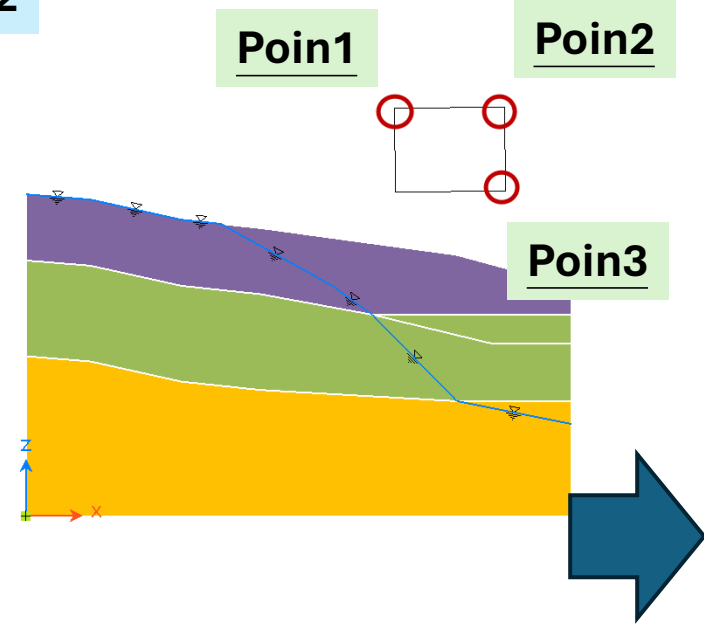

Draw Grid Range
依照順序空間點選Point1~Point3

預設節點間隔 (1m)

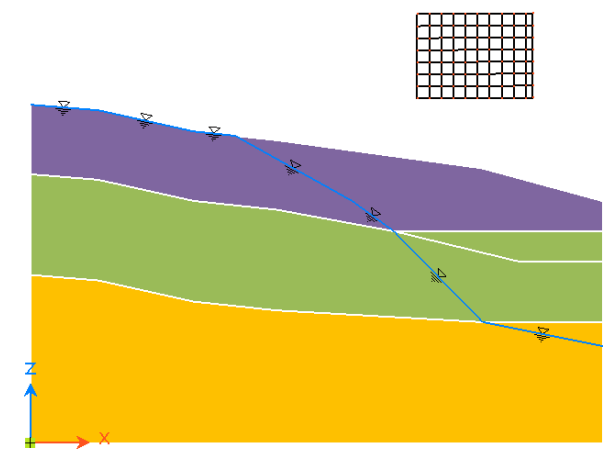

開挖2-破壞面-2

(Arc Failure Surface-Radius Data)

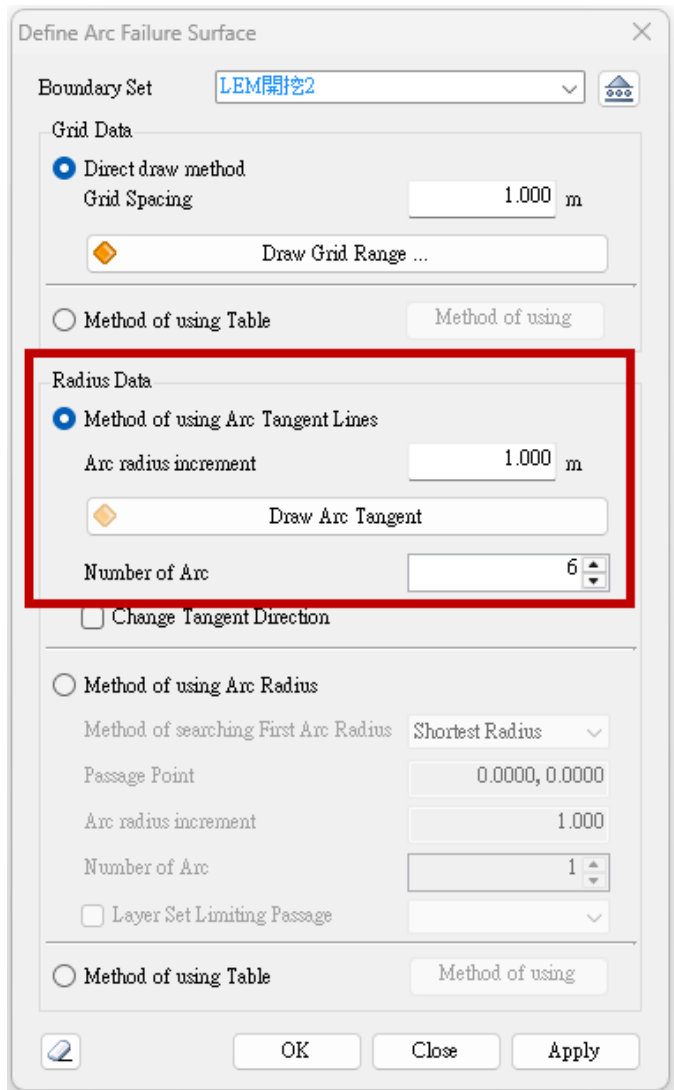

破壞面區域定義

預設採Arc Tangent Method

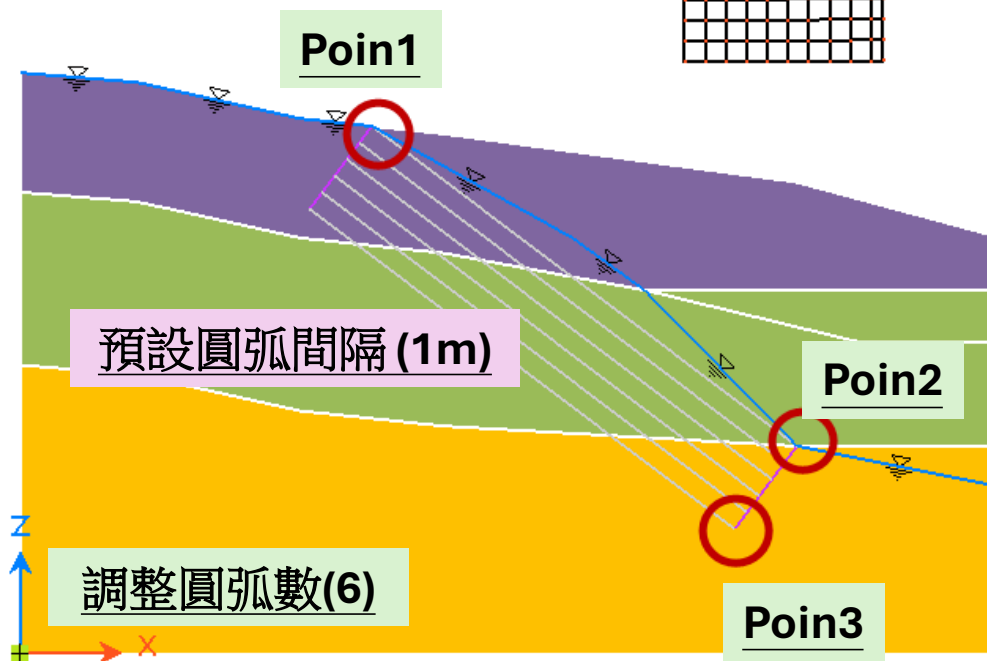

Radius Data



Limit Equilibrium Method

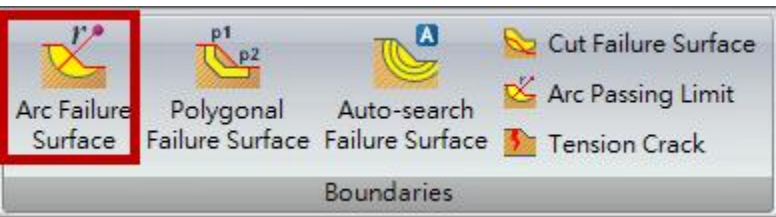

開挖3-破壞面-1 (Arc Failure Surface-Grid Data)

自訂Boundary Set名稱: LEM開挖3

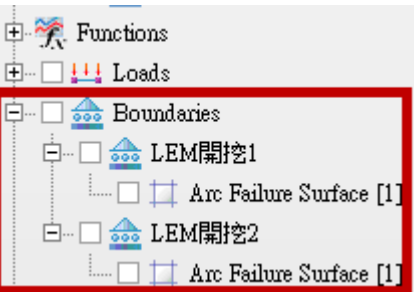

隱藏LEM開挖1&2

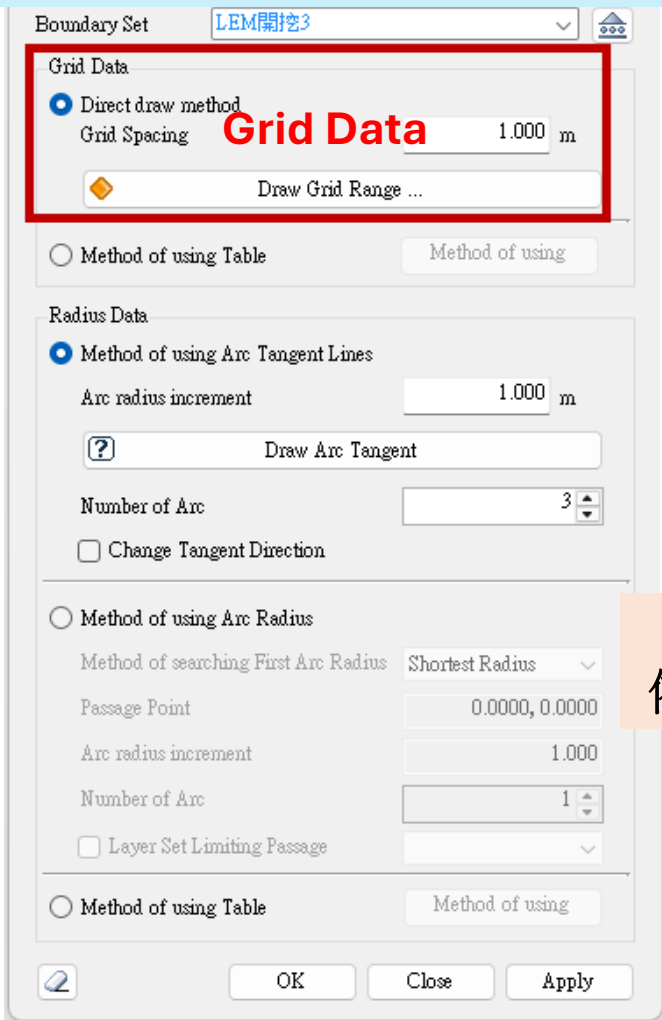

圓弧中心區域定義

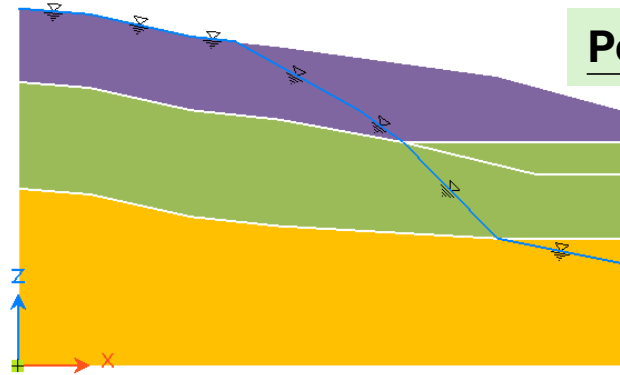
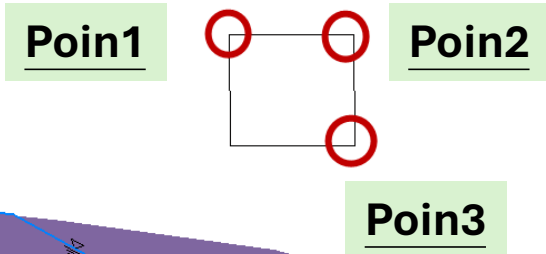

Draw Grid Range
依照順序空間點選Point1~Point3

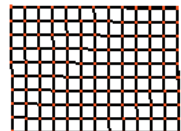

預設節點間隔 (1m)

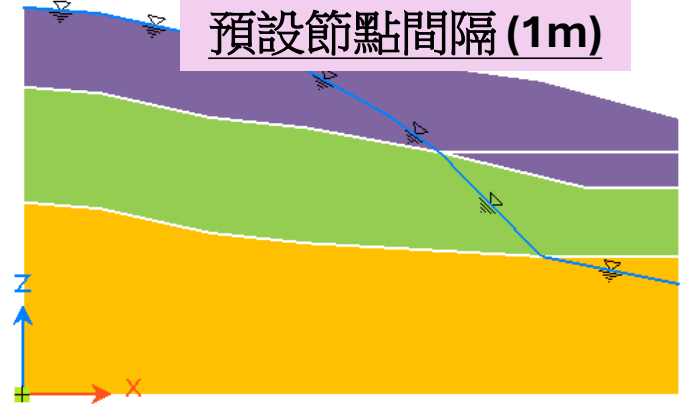

開挖3-破壞面-2

(Arc Failure Surface-Radius Data)

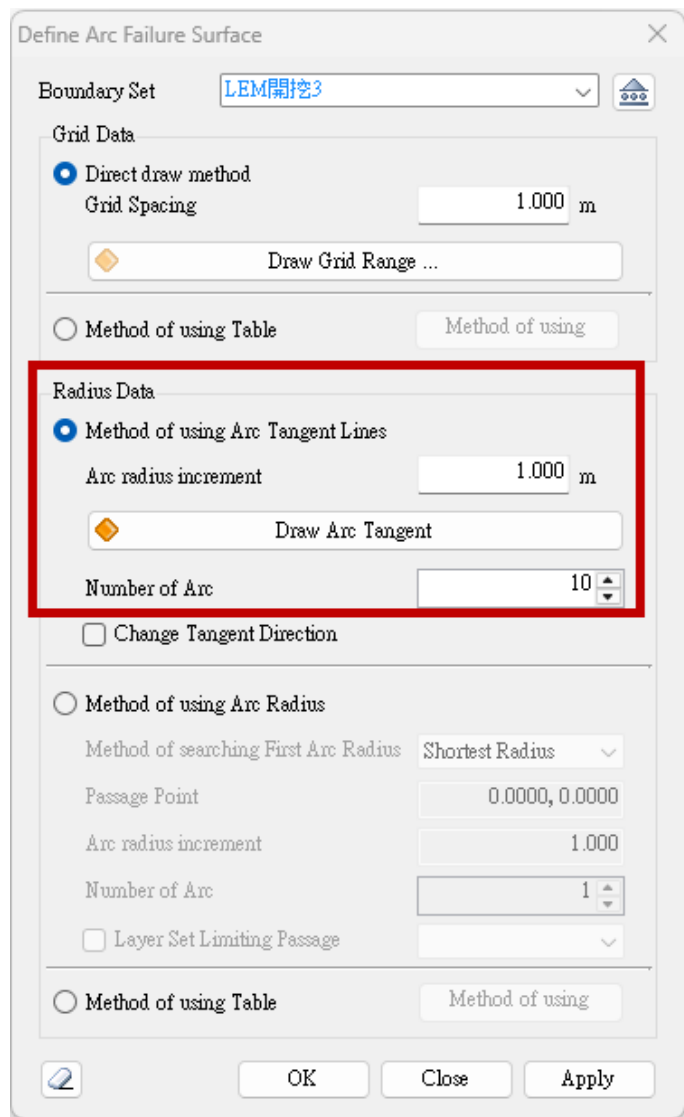

破壞面區域定義

預設採Arc Tangent Method

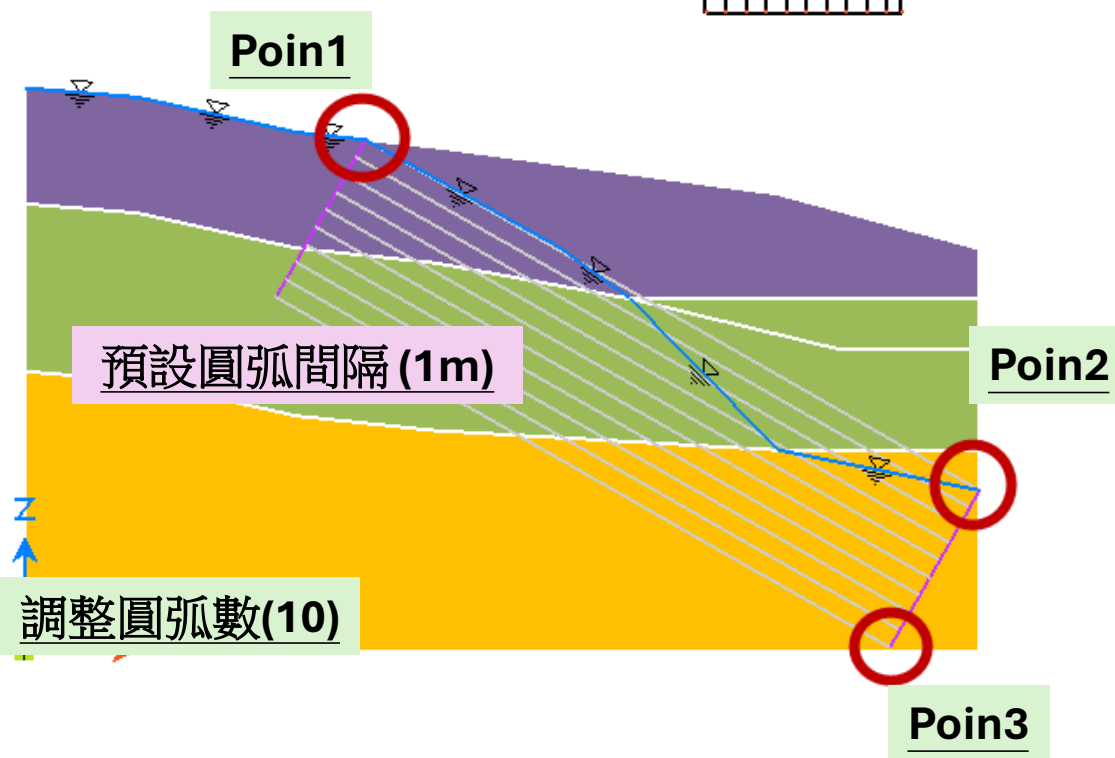
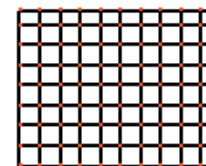

Radius Data



LEM邊坡開挖-施工流程

Stage1.Excavation 1

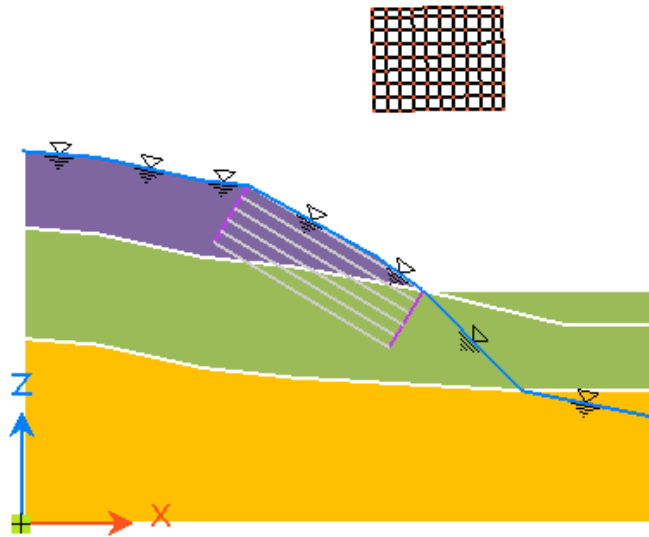

Stage2.Excavation 2

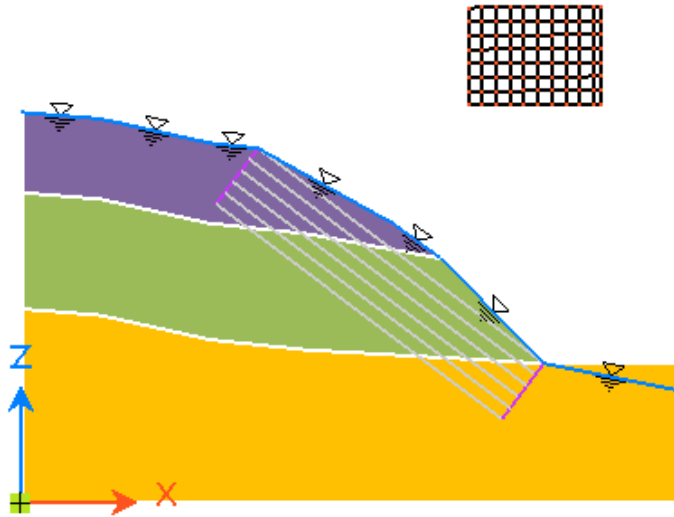

Stage3.Excavation 3

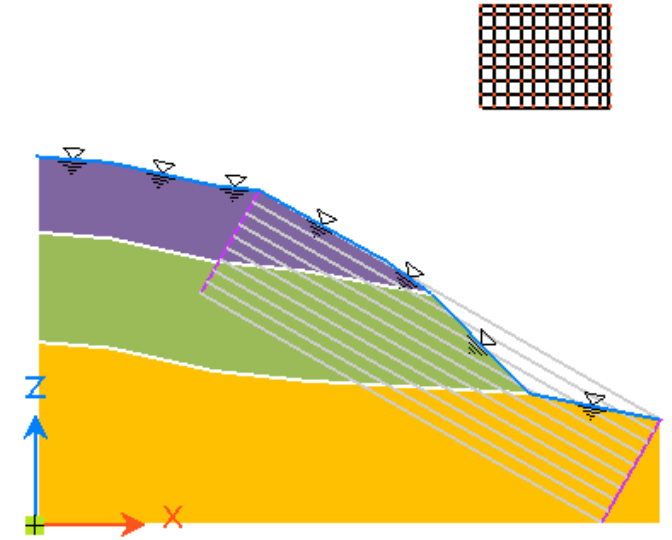



LEM 施工階段新增

(Stage1. Excavation1 ~ Stage3. Excavation3)

Stage1. Excavation1

Analysis Type : LEM

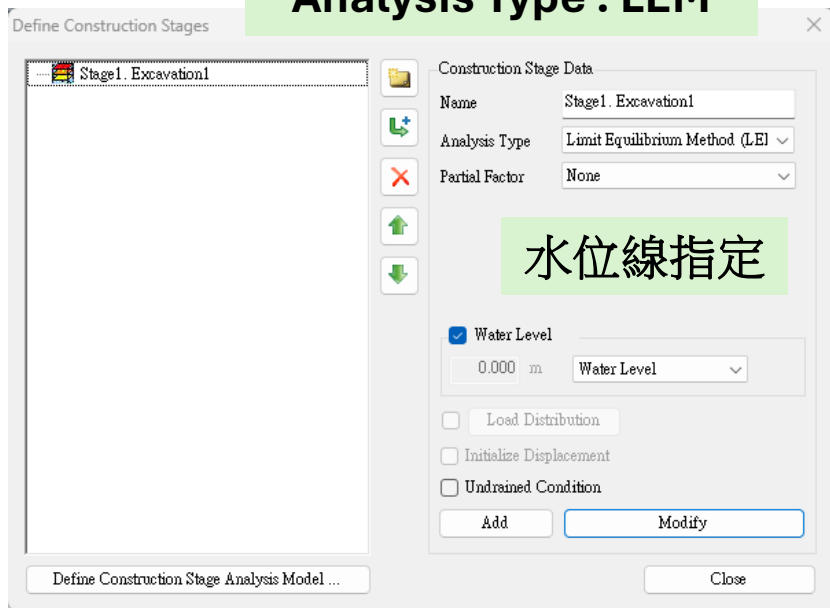

Add 新增施工階段

Stage2. Excavation2

Analysis Type : LEM

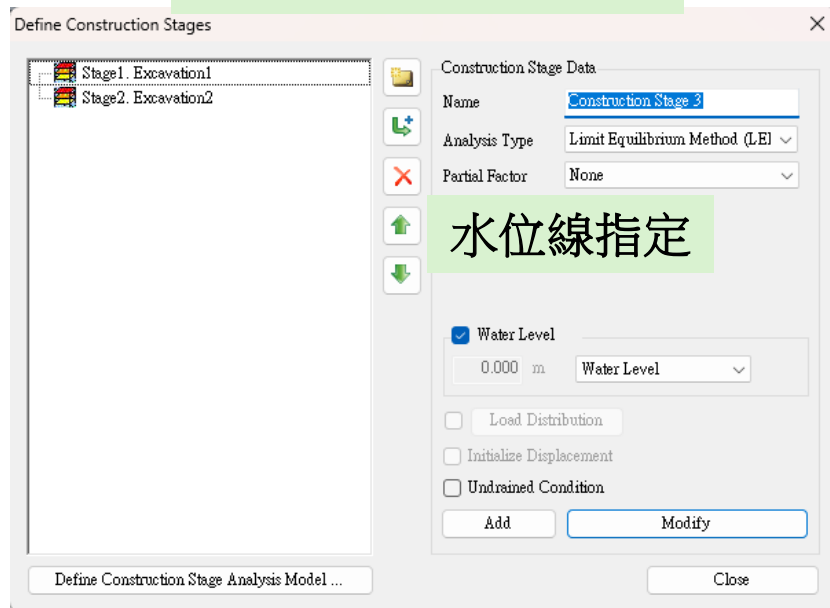

Add 新增施工階段

Stage3. Excavation3

Analysis Type : LEM

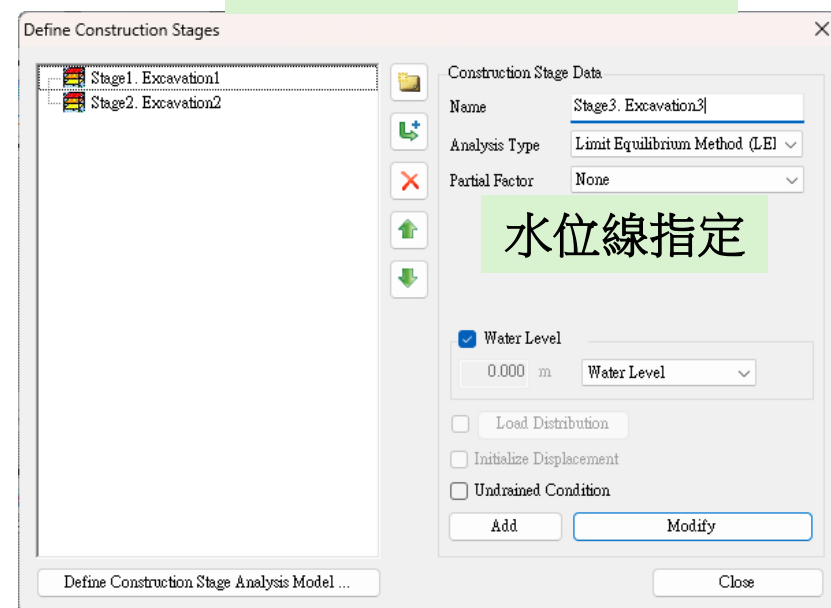

Add 新增施工階段





LEM施工階段編輯-1

(Stage1.Excavation 1)

開啟施工階段檢視

Construction Stage Analysis Model

Input Type: Tree Style Table Style Simulate Each Stage

Step: Stage1. Excavation1 **Apply** (with red arrow pointing to it)

All Input Data	Activated Data at Current Stage	Deactivated Data at Current Stage
<ul style="list-style-type: none"> Layer Set <ul style="list-style-type: none"> 0 base Smart Surface 1 Smart Surface 3 Smart Surface 6 開挖1 開挖2a 開挖2b 開挖3 Boundary Set <ul style="list-style-type: none"> LEM開挖1 LEM開挖2 LEM開挖3 Load Set Self Weight 	<ul style="list-style-type: none"> Layer Set <ul style="list-style-type: none"> 0 base Smart Surface 1 Smart Surface 3 Smart Surface 6 開挖1 開挖2a 開挖2b 開挖3 Boundary Set <ul style="list-style-type: none"> LEM開挖1 Load Set Self Weight 	<ul style="list-style-type: none"> Layer Set Boundary Set Load Set

Define Construction Stages: **Close**

完成後點Apply

拖曳全部土壤(不含開挖區域1)幾何集
 LEM開挖1邊界集
 Self Weight載荷集

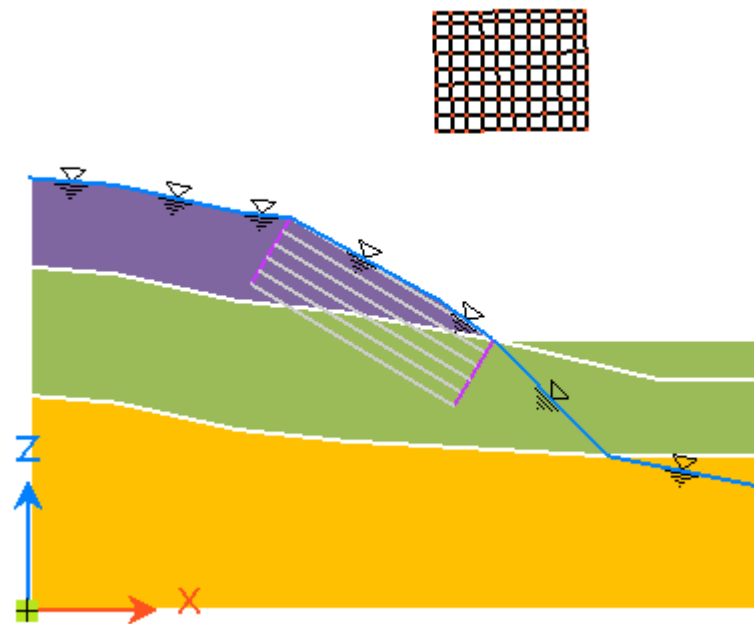



LEM施工階段編輯-2

Stage1. Excavation1 to Stage3. Excavation3)

Stage2. Excavation 2

Activated
LEM開挖2邊界集

Deactivated
拖曳幾何集開挖2a&2b
LEM開挖1邊界集

Stage3. Excavation 3

Activated
LEM開挖3邊界集

Deactivated
拖曳幾何集開挖3
LEM開挖3邊界集

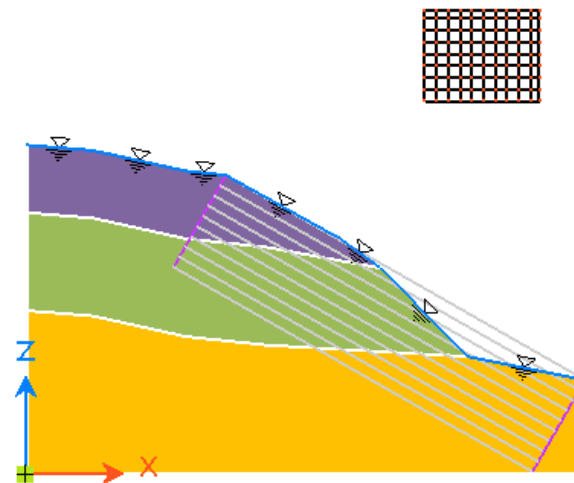
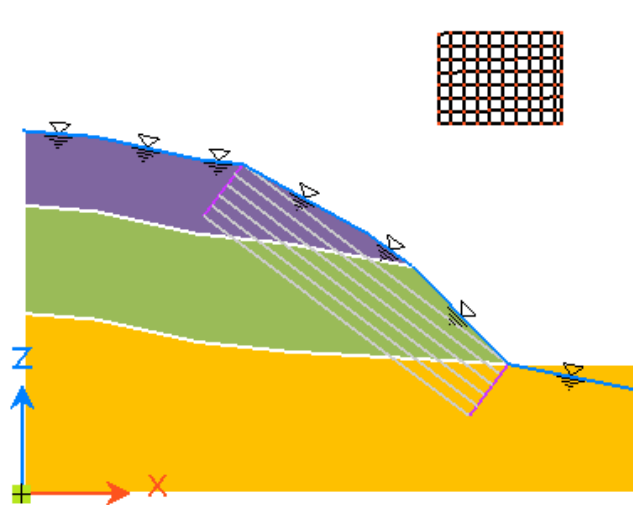

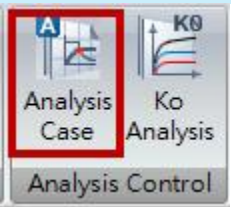

分析定義 (LEM邊坡穩定性分析)

分析名稱: LEM邊坡穩定性分析/分析類型: Construction Stage

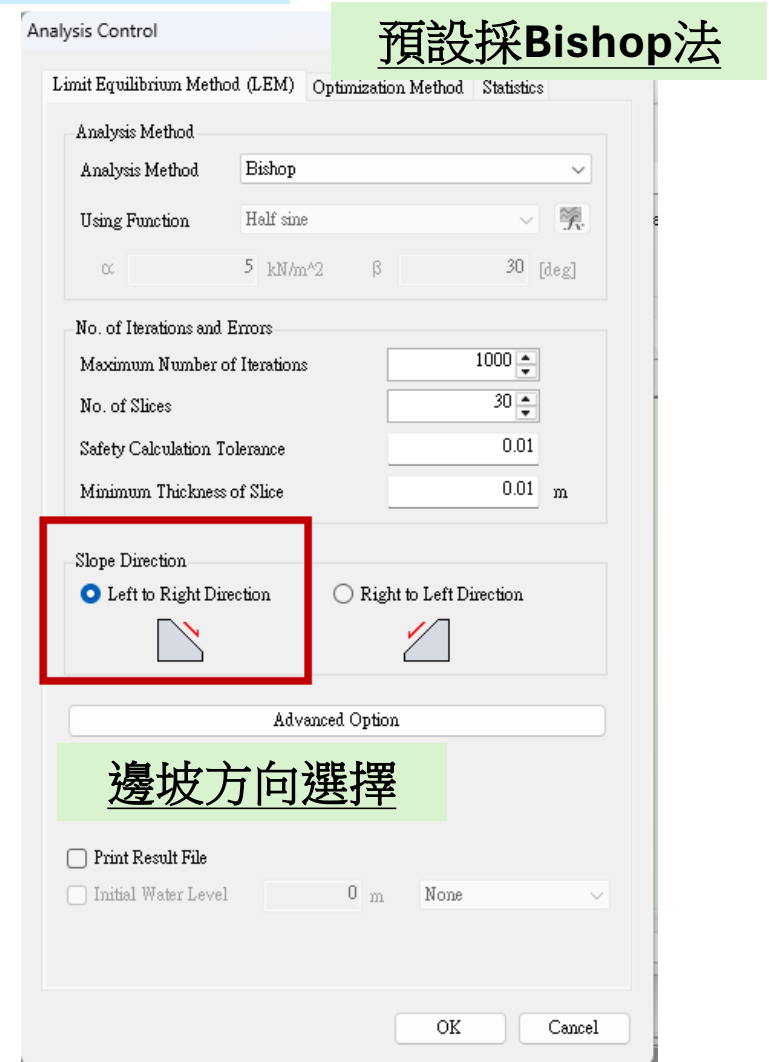
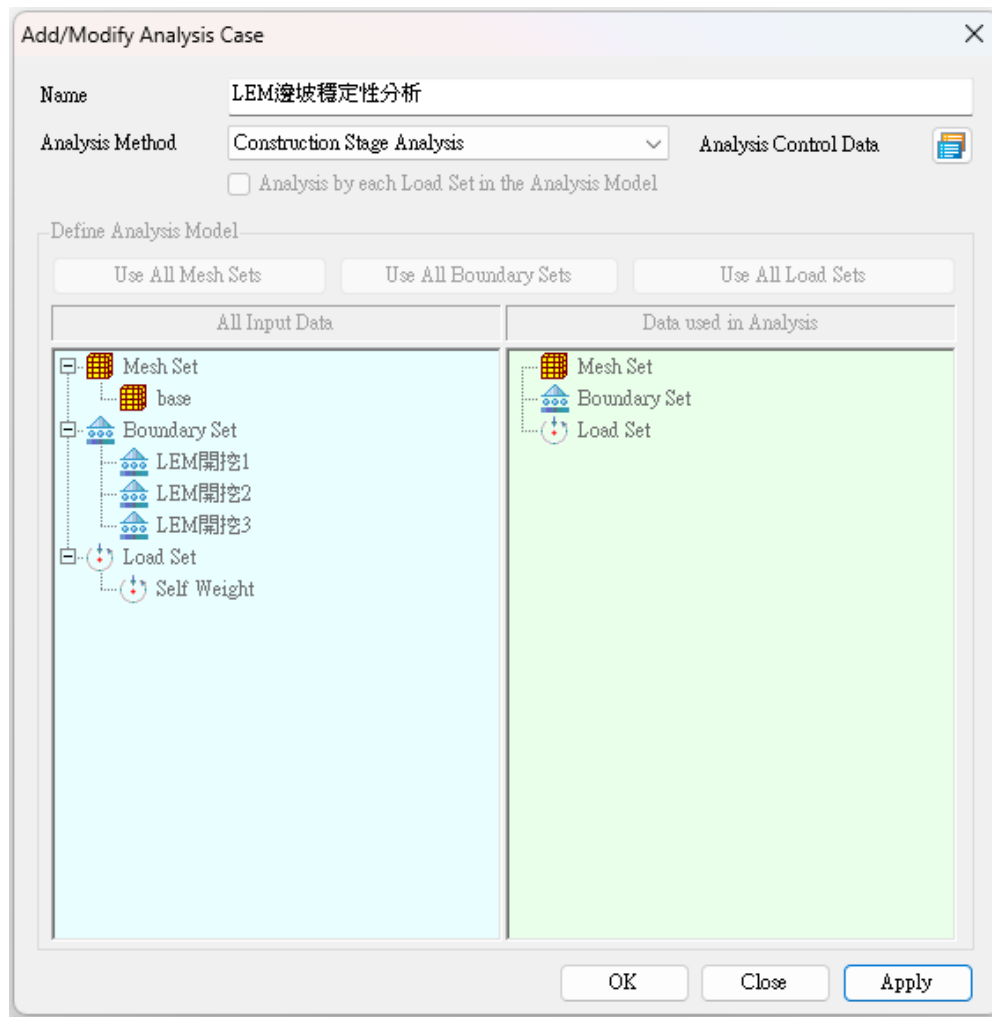
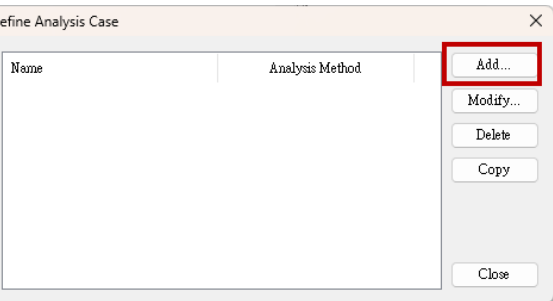

計算

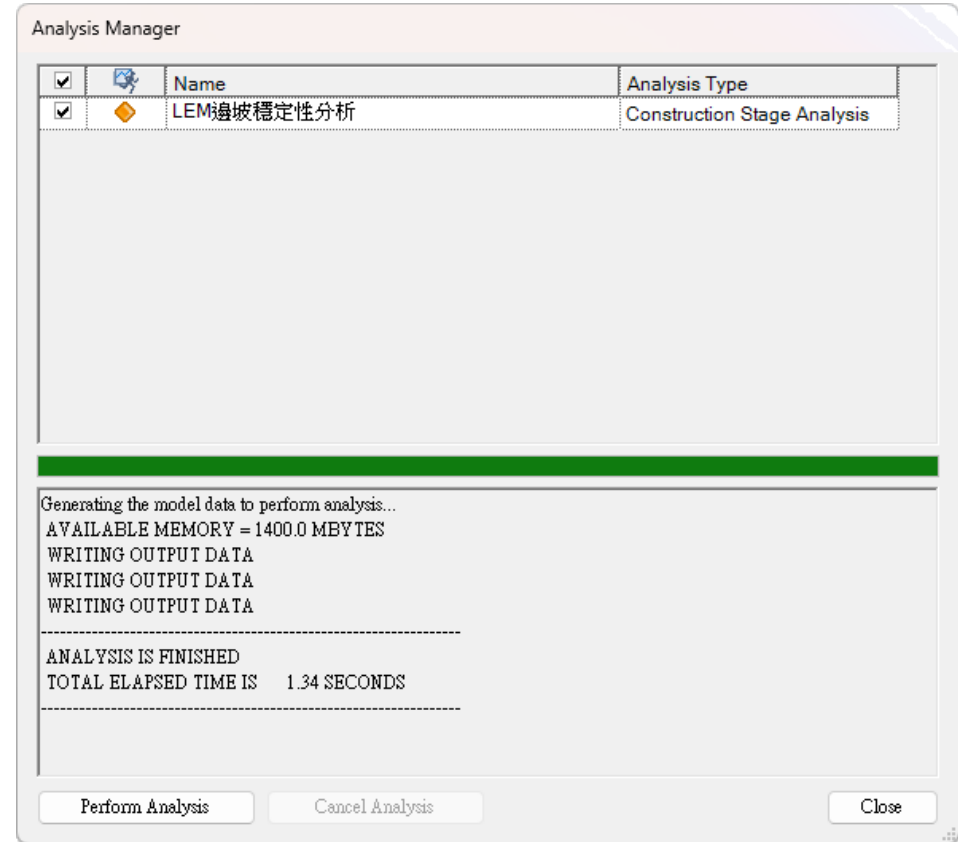
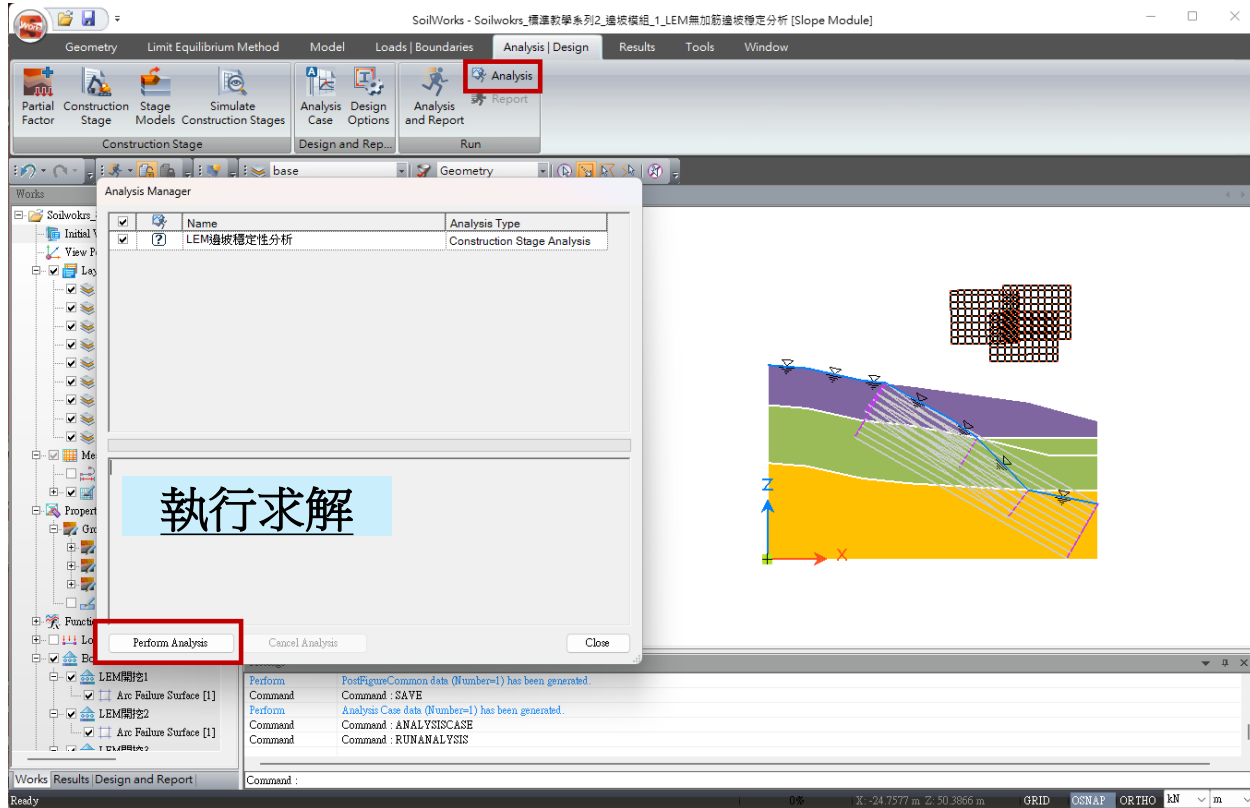

依照施工階段定義順序 輸出結果

LEM分析結果

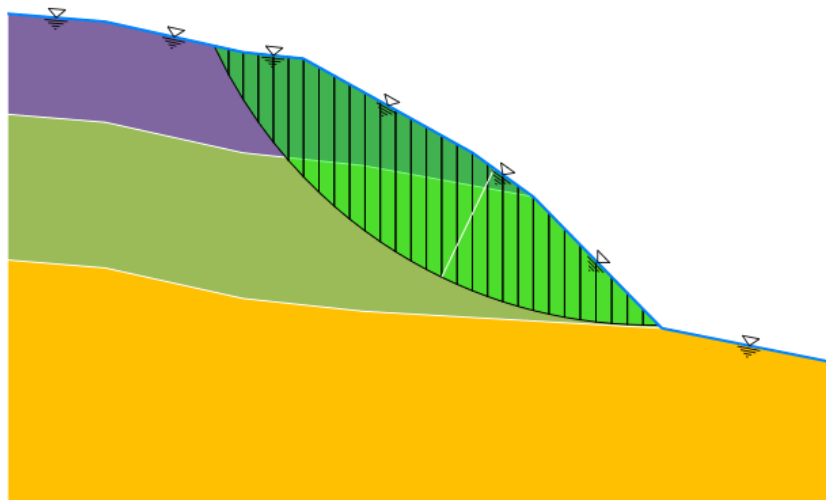
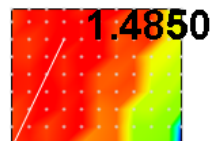
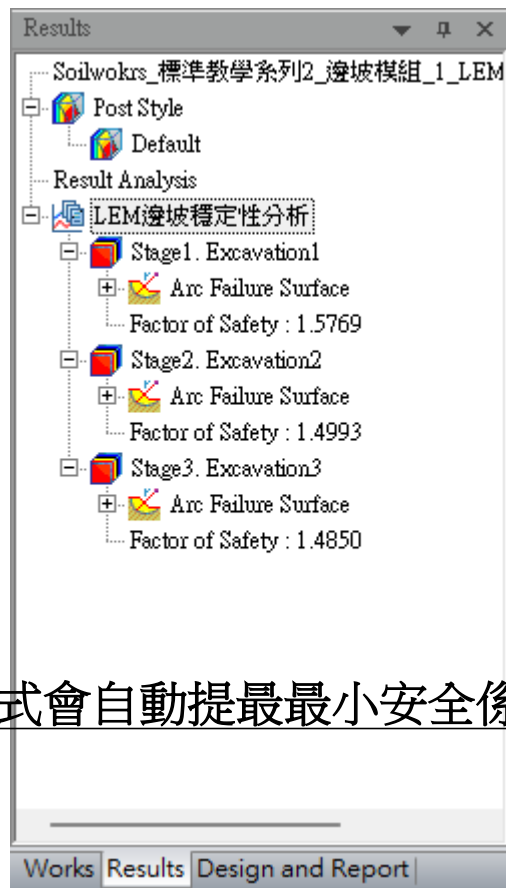

SoilWorks®

Safety Factor

0.6%	+2.68673e+000
1.1%	+2.61163e+000
1.1%	+2.53652e+000
1.1%	+2.46141e+000
1.1%	+2.38631e+000
1.1%	+2.31120e+000
1.1%	+2.23609e+000
1.1%	+2.16098e+000
1.1%	+2.08588e+000
1.1%	+2.01077e+000
1.7%	+1.93566e+000
10.3%	+1.86056e+000
9.2%	+1.78545e+000
5.7%	+1.71034e+000
9.8%	+1.63524e+000
26.2%	+1.56013e+000
25.3%	+1.48502e+000

程式會自動提最最小安全係數



Part2.SRM無加筋邊坡穩定分析

(Strength Reduction Method (SRM)-強度折減法)



SRM邊坡開挖-施工流程

Stage0. Initial

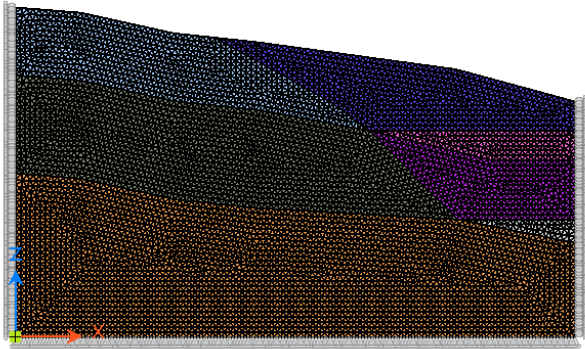

Stage1. Excavation 1

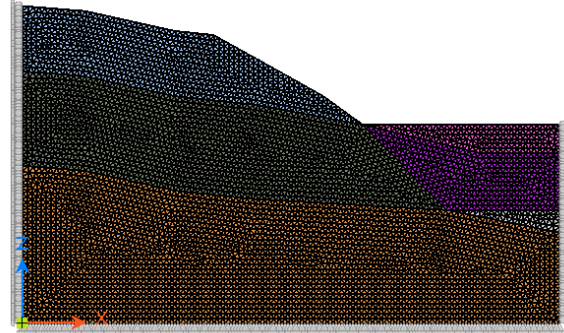

Stage2. Excavation 2

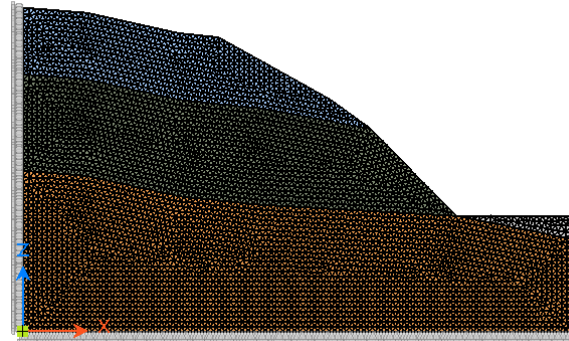

Stage3. Excavation 3

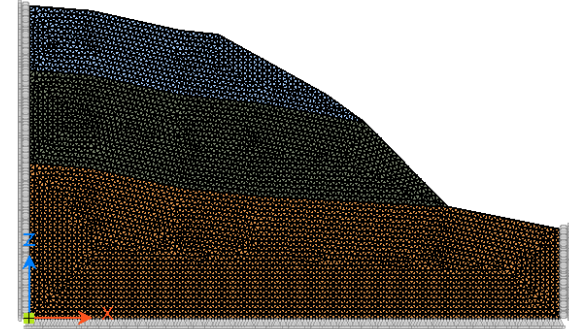

2側自由度
拘束Tx

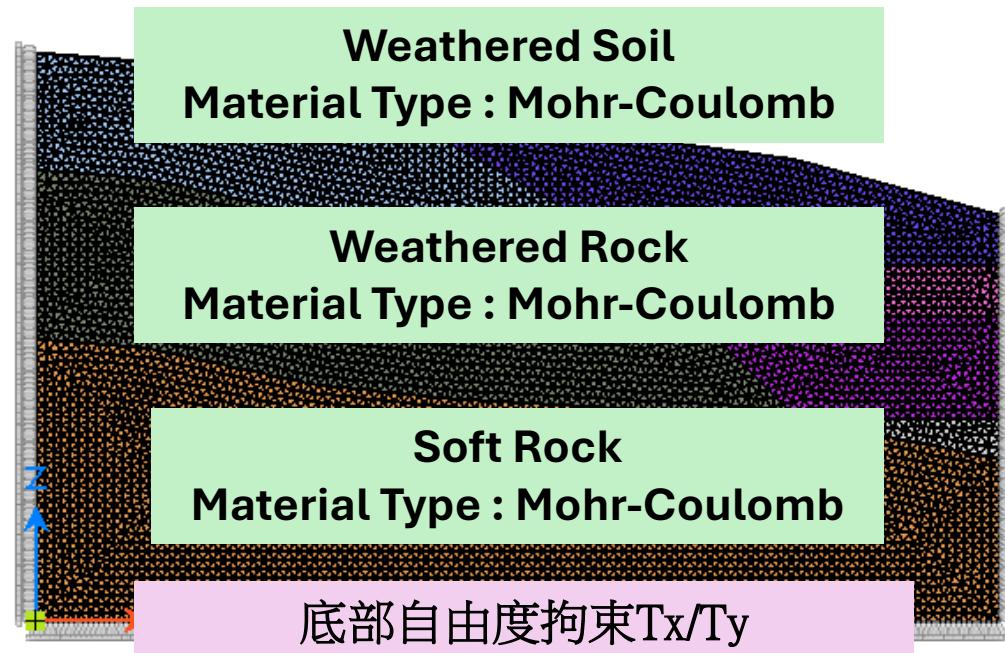

2側自由度
拘束Tx

Strength Reduction Method (SRM)

(強度折減法)

有限元素法分析邊坡穩定性的方法有兩類：

- (1)直接法:強度折減法
- (2)間接法:應力分析法(結合極限平衡法進行安全係數計算)

強度折減法(SRM)

將邊坡地基材料的抗剪強度 (c, ϕ) 逐漸減小，直到計算中的發散點，此時假定發生了斜坡破壞，該點的最大強度折減率被認為是最小安全係數。

強度折減法需要迭代非線性分析，消耗大量分析時間，

- (1) 當土體的抗剪強度小於土體自重所引起的剪應力時，就會發生破壞，所以不需假設失效面。
- (2) 不需使用切片的概念直接進行計算，同時滿足平衡狀態直致失效。
- (3) 計算得到現地邊應力和變形。

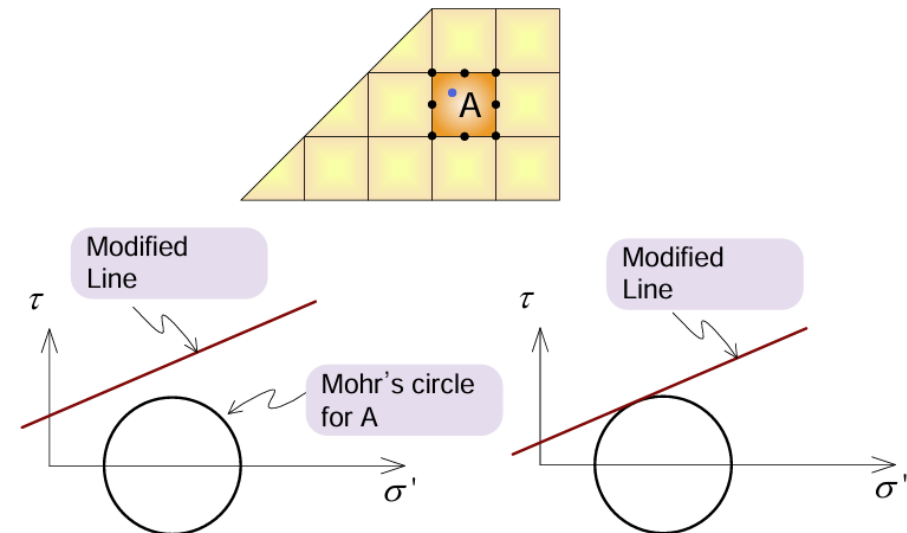

Reference

GTS NX/FEA NX/Soilworks Manual



邊坡(Slope)模組



選擇邊坡(Slope)模組

Limit Equilibrium Method(LEM)-極限平衡法

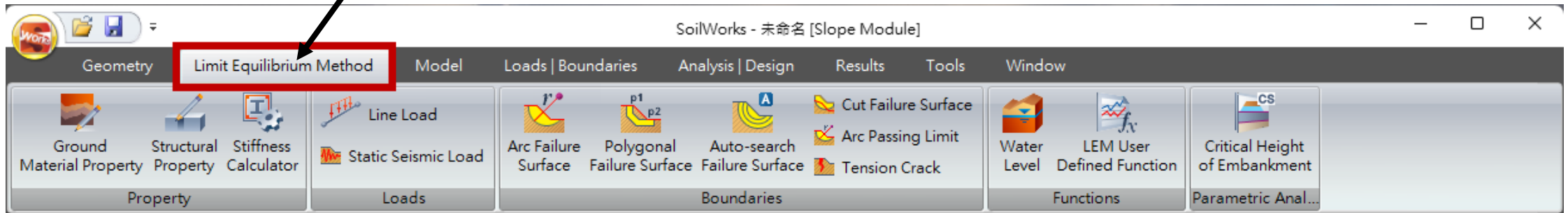

單位切換

The screenshot displays the MIDAS Gen software interface. The main window shows a project tree on the left and a central workspace. Two dialog boxes are open:

- Define Initial Parameters:** A dialog box with a title bar "Define Initial Parameters". It has tabs for "Unit System", "Force", "Length", "m", and "Time", "sec". Under "Unit System", "SI", "CGS", "FPS", and "User Defined ..." are listed. The "Initial Parameters" section includes:
 - Gravitational Acceleration: 9.807 m/sec²
 - Unit Weight of Water: 9.807 kN/m³
 - Initial Temperature: 0.000 [T]Buttons for "Project Information..." and "OK" are at the bottom.
- Unit settings:** A dialog box titled "Unit settings" with a close button (X). It has three columns:
 - Force Unit [F]:** Radio buttons for kgf, tonf, N, **kN** (selected), lbf, kips.
 - Length Unit [L]:** Radio buttons for **m** (selected), cm, mm, ft, inch.
 - Time Unit [T]:** Radio buttons for **sec** (selected), min, hour, day.Buttons for "Reset", "OK", and "Cancel" are at the bottom.

A 3D coordinate system with X, Y, and Z axes is visible in the workspace.



DWG模型匯入

Import>CAD File

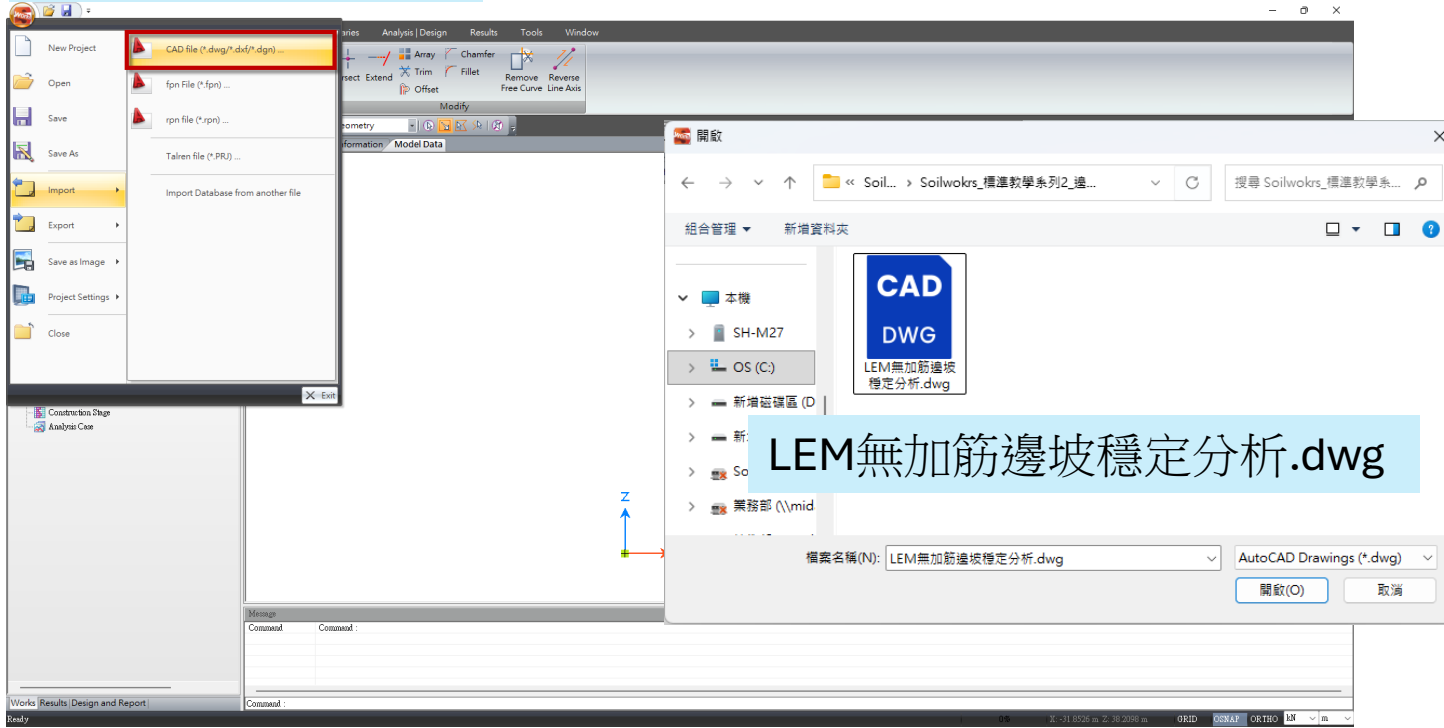

匯入後線特徵模型

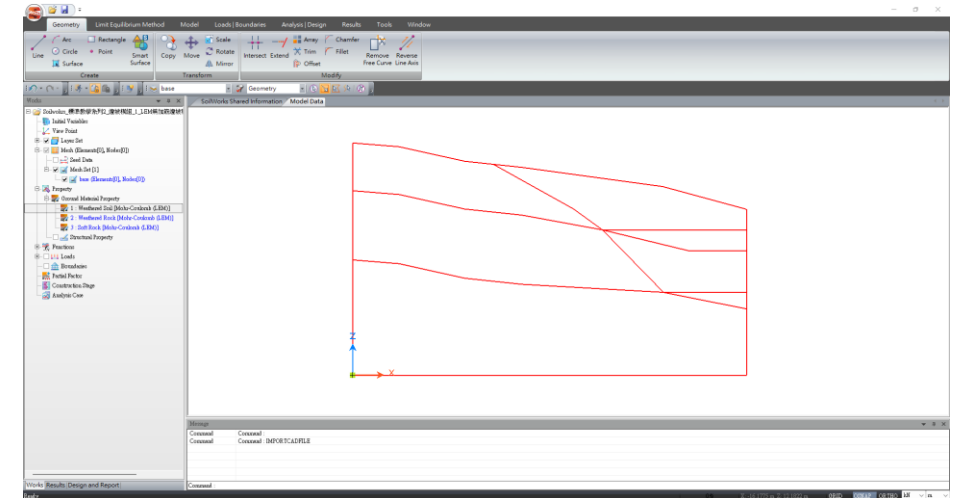
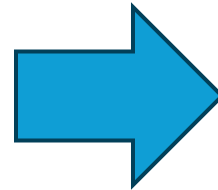

DWG模型匯入

Import>CAD File

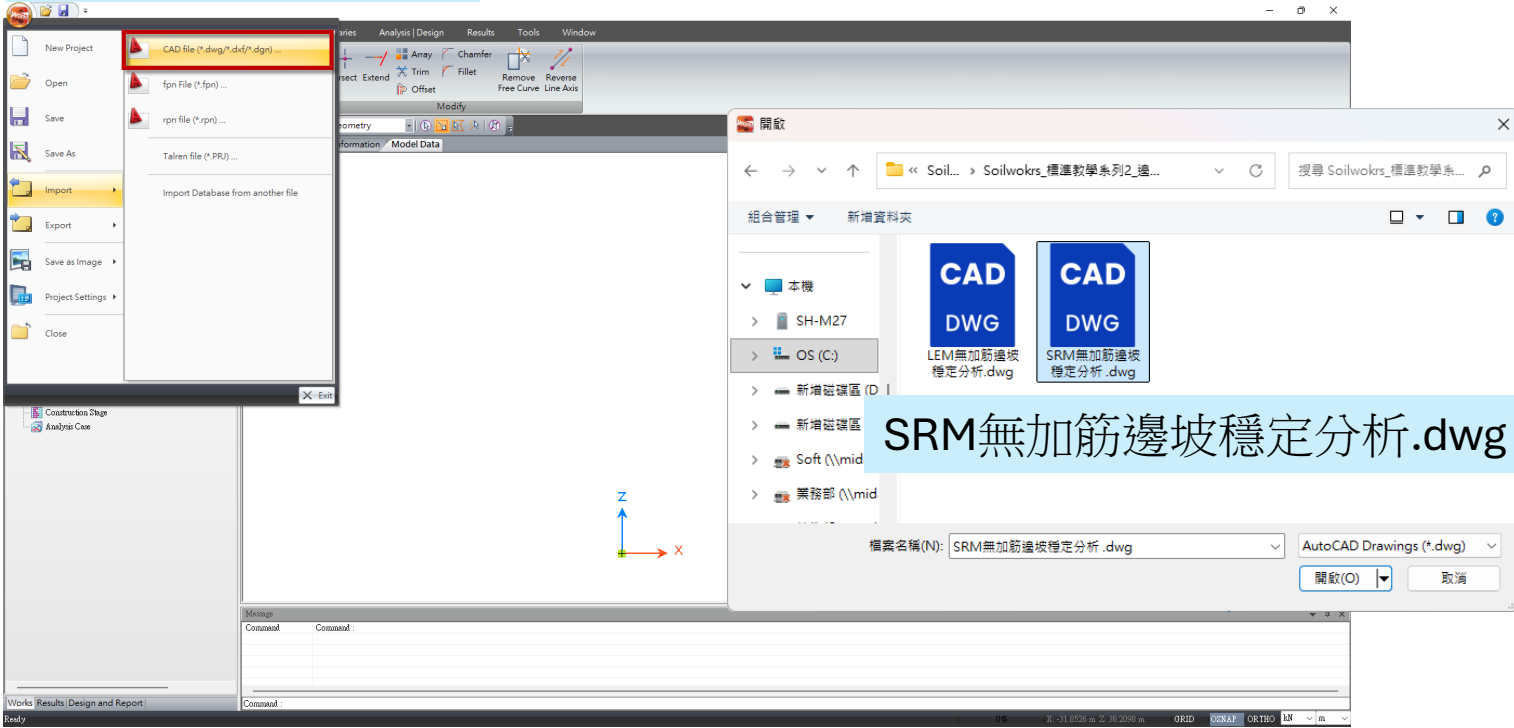

匯入後線特徵模型

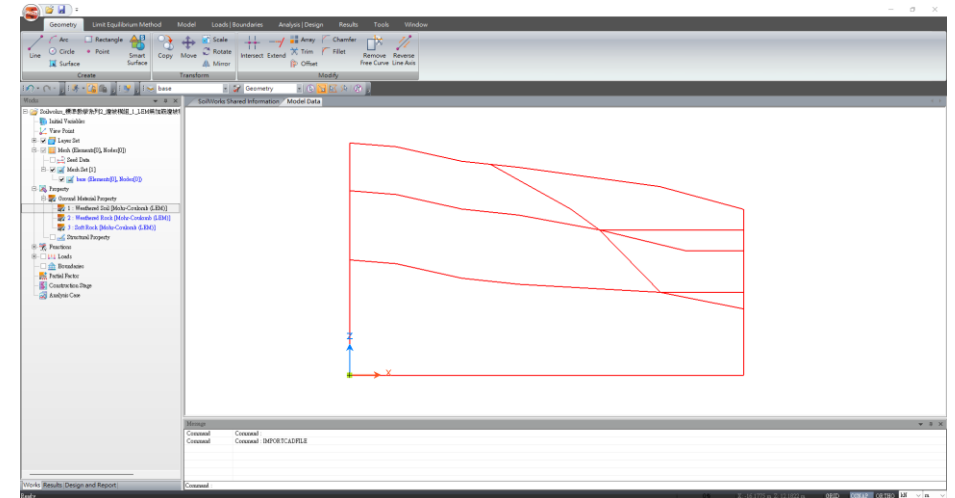
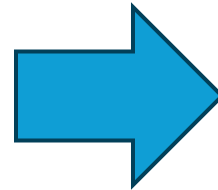

土壤材料屬性(Soilworks材料庫)

Model

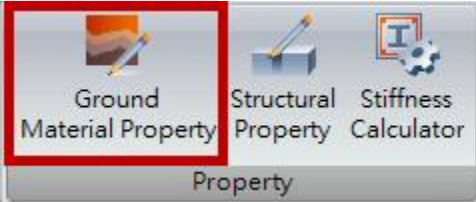

選取 1.1schist#1 類別

Ground Material Database

Database: 1.1 Schist#1

No.	Soil Type	Modulus of Elasticity (kN/m ²)	Unit Weight (kN/m ³)	Saturated Unit Weight (kN/m ³)	Poisson's Ratio	Cohesion (kN/m ²)	Internal Friction Angle	Select
1	Landfill Layer	13000	18	19	0.33	0	27	<input type="checkbox"/>
2	Alluvial Layer	8000	17	18	0.35	15	20	<input type="checkbox"/>
3	Weathered Soil	36500	18.5	19.5	0.33	17.5	31	<input checked="" type="checkbox"/>
4	Weathered Ro	150000	21	22	0.3	50	33	<input checked="" type="checkbox"/>
5	Soft Rock	1850000	24	25	0.28	180	35.5	<input checked="" type="checkbox"/>
6	Hard Rock	17500000	26	27	0.23	1750	40.5	<input type="checkbox"/>

選取 No3~No5

Assign新增材料

Define Ground Material Property

Data: ID 1, Name [redacted]

General: Model Type: Mohr-Coulomb

General Parameters:

Modulus of Elasticity (E)	20000000	kN/m ²
Poisson's Ratio (u)	0.3	
Temperature Coeff. (α)	1E-06	
Unit Weight (γt)	20	kN/m ³
Saturated Unit Weight	21	kN/m ³
Cohesion (c)	30	kN/m ²
Internal Friction Angle (Φ)	36	[deg]
Earth Pressure Coeff. (K0)	1	
Draining Condition	Drained	

Additional Parameters:

Variation in Modulus of Elasticity	0	kN/m ²
Variation in Cohesion	0	kN/m ²
Reference Height	0	m
<input type="checkbox"/> Dilatancy Angle (ψ)	36	[deg]
<input type="checkbox"/> Tensile Strength	2000	kN/m ²

Database ... Material Statistic Add Modify Delete Close

Soilworks材料庫

完成Mohr-Coulomb土壤材料新增



Geometry 選單>Smart Surface

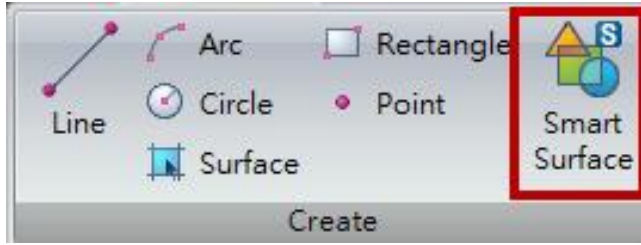

自動生成面特徵

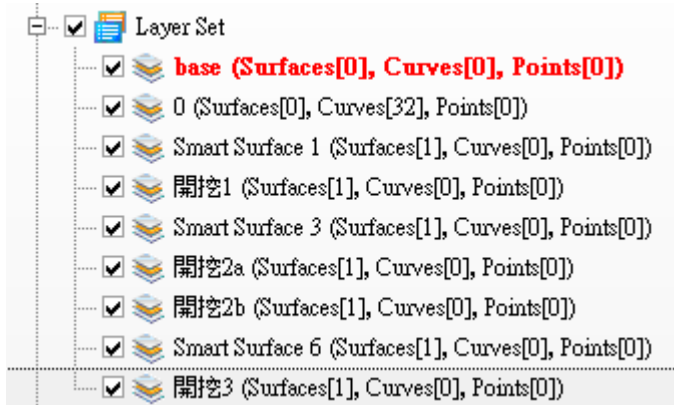

面特徵建立

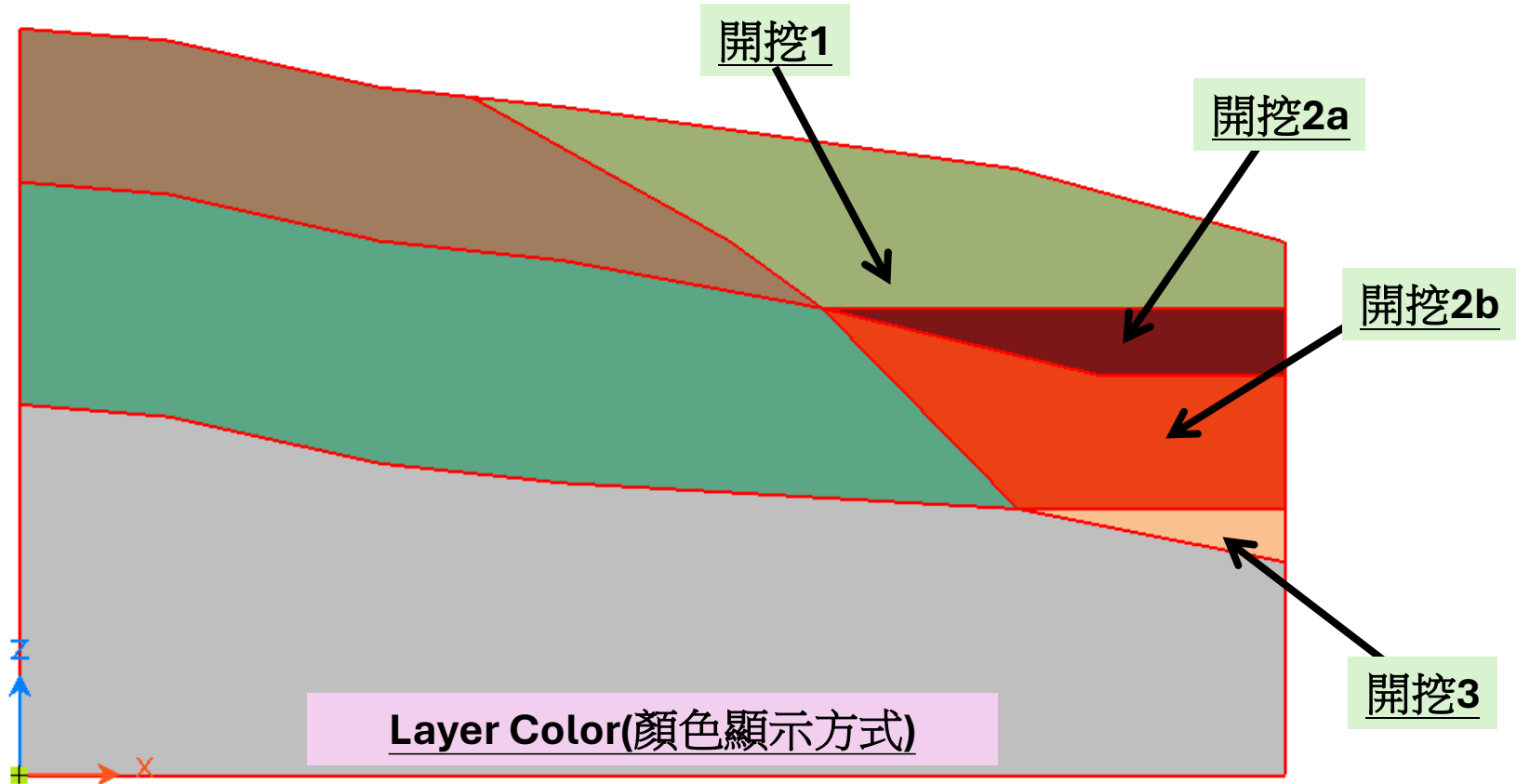

顏色顯示(補充)

自訂屬性顏色

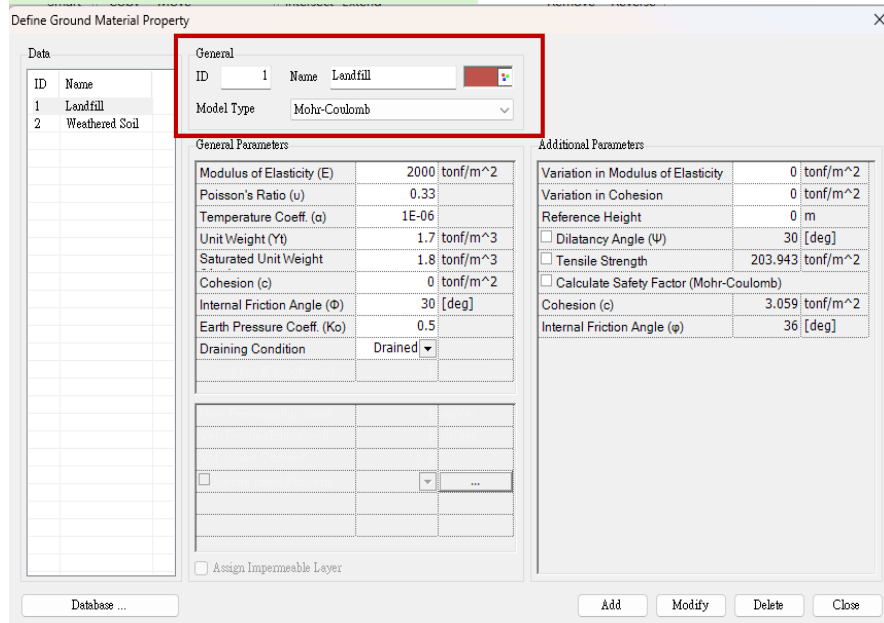

Display Setting顯示設定

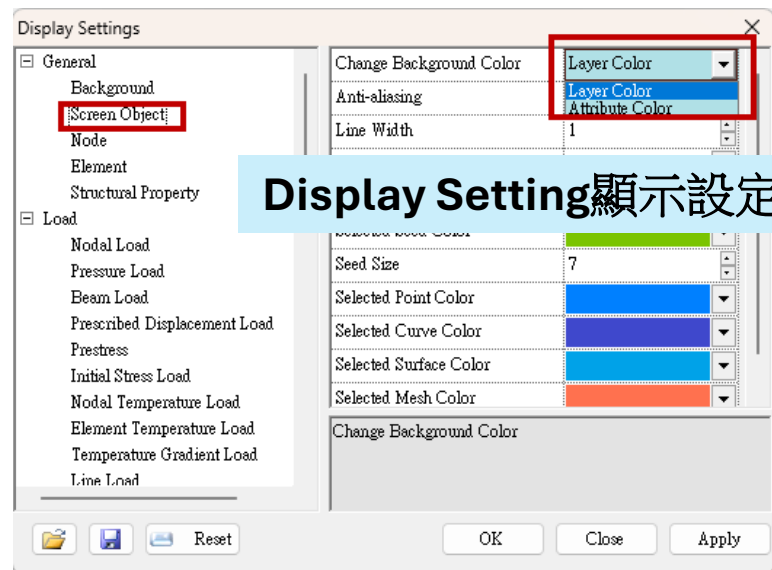

Display Setting顯示設定



Attribute Color (顏色顯示方式)
(Property Color)

土壤材料屬性指定

Select Filter 切換到 Surface

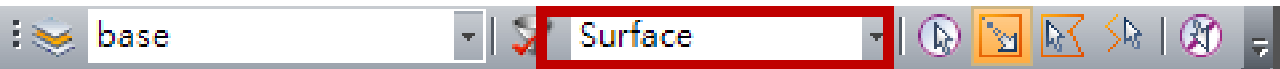

框選 Weathered Soil 分布區域特徵

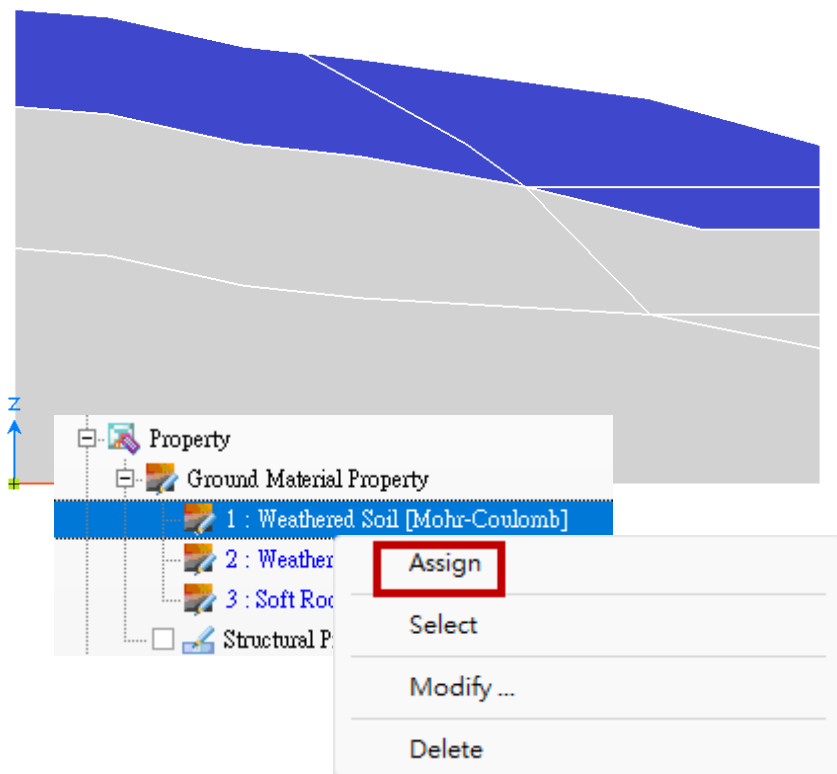

框選 Weathered Rock 分布區域特徵

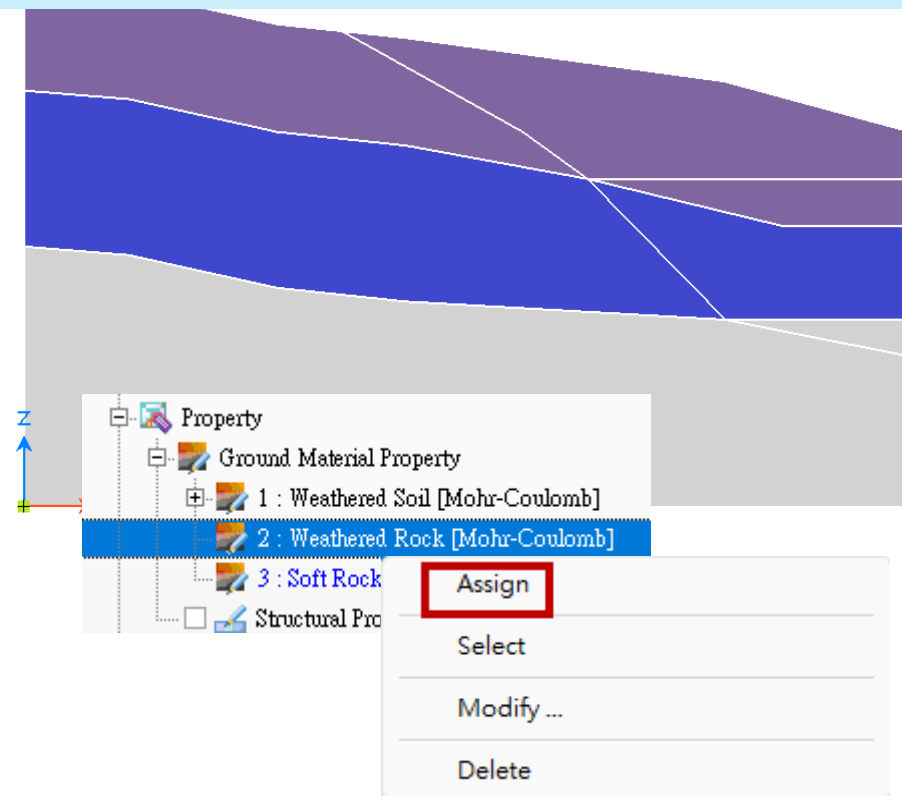

土壤材料屬性指定

Select Filter 切換到 Surface

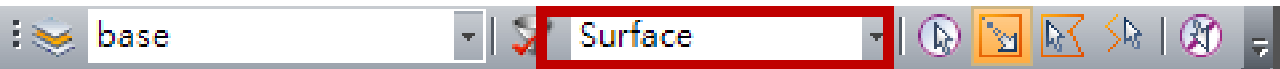

框選 Soft Rock 分布區域特徵

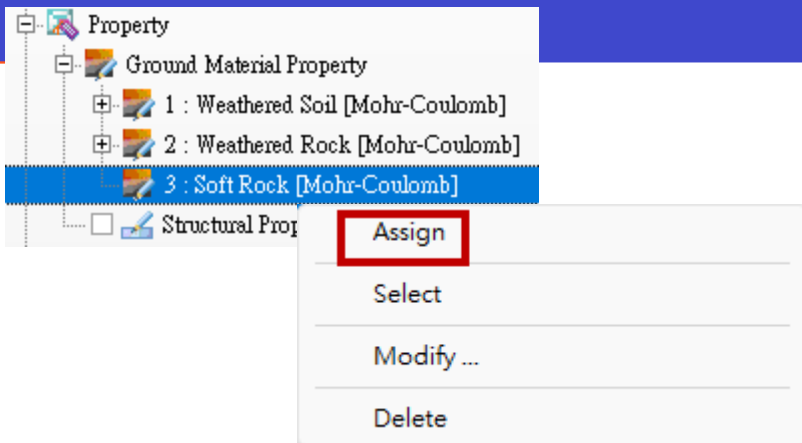
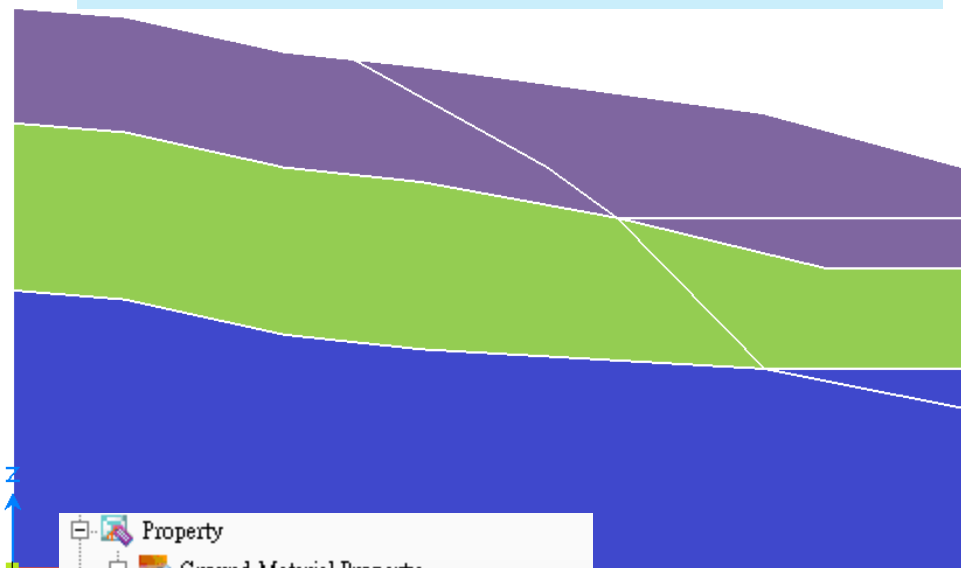

Ground Material Property 模型樹顯示指定特徵數量

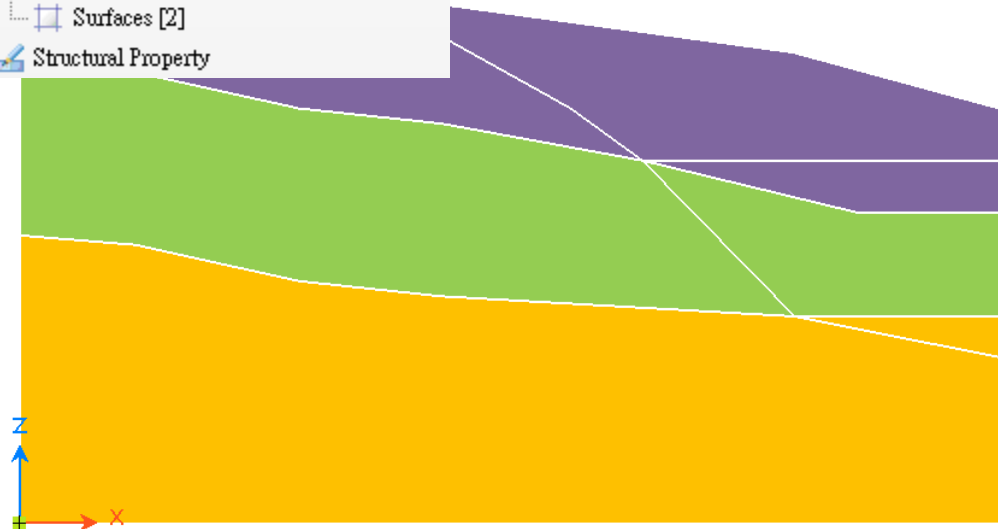
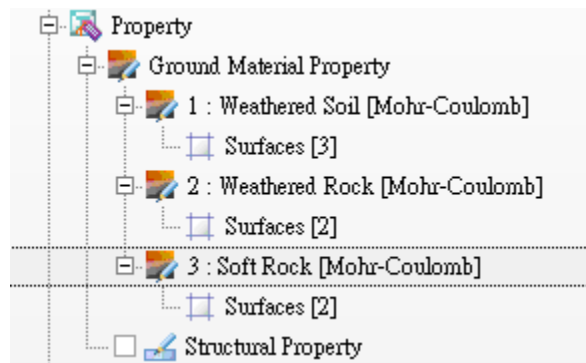

Model選單> Mesh

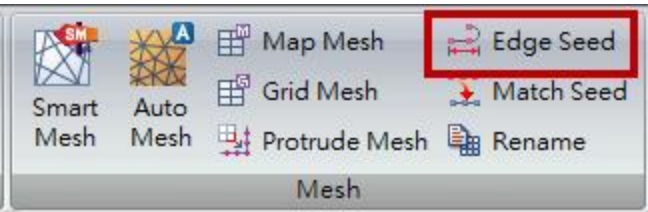

指定網格尺寸

Select Filter 切換到 Curve

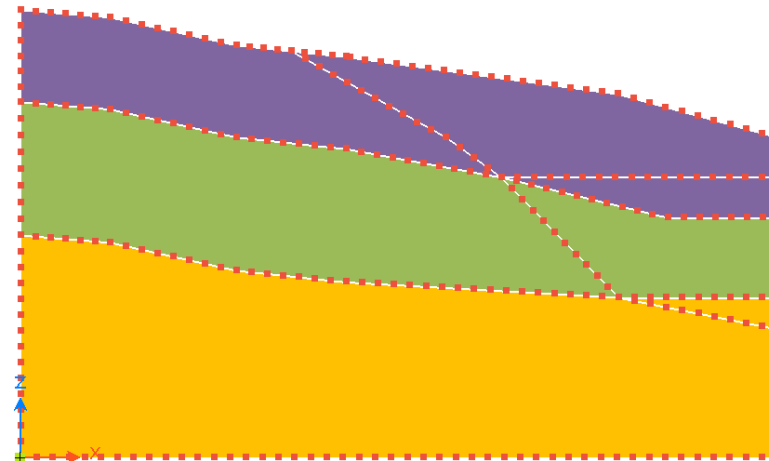
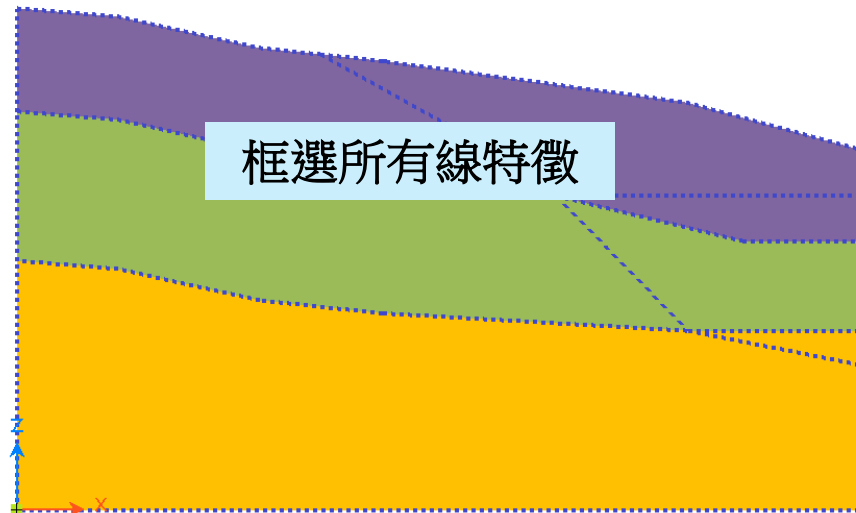
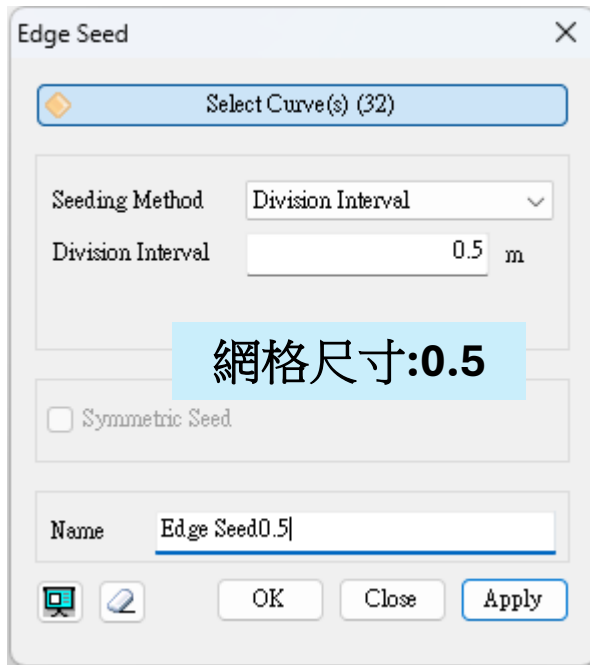
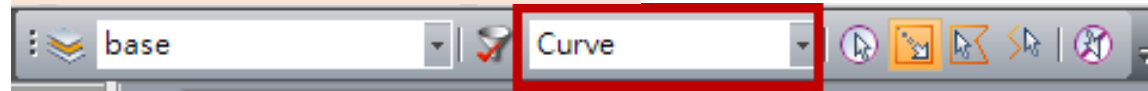

2D網格生成

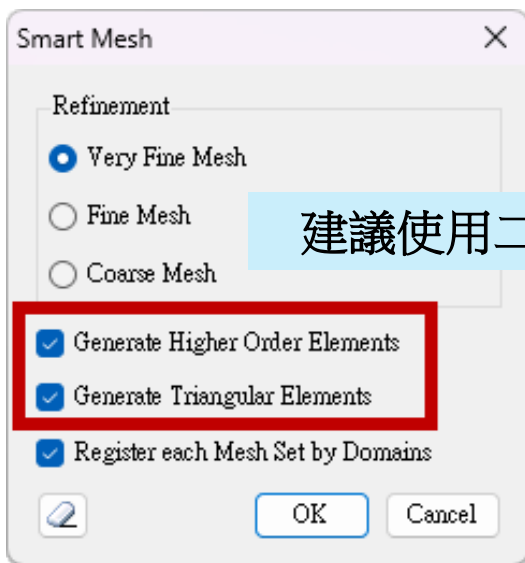

建議使用二階&三角形元素

每個面特徵各別生成網格集

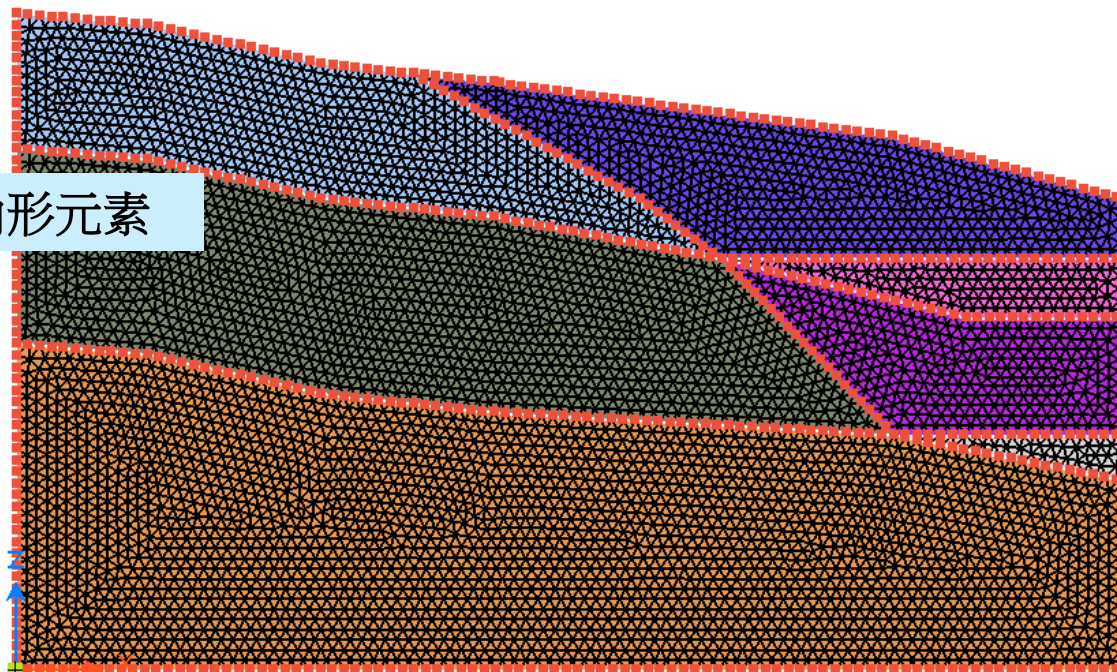

水位線

Loads | Boundaries



Water Level

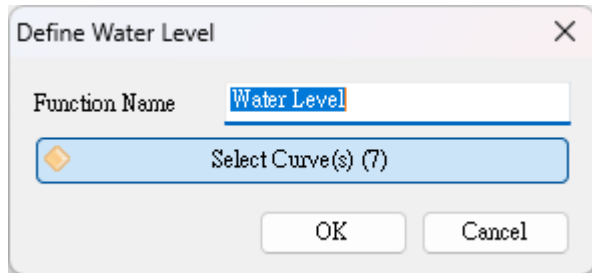

Select Filter 切換到 Curve

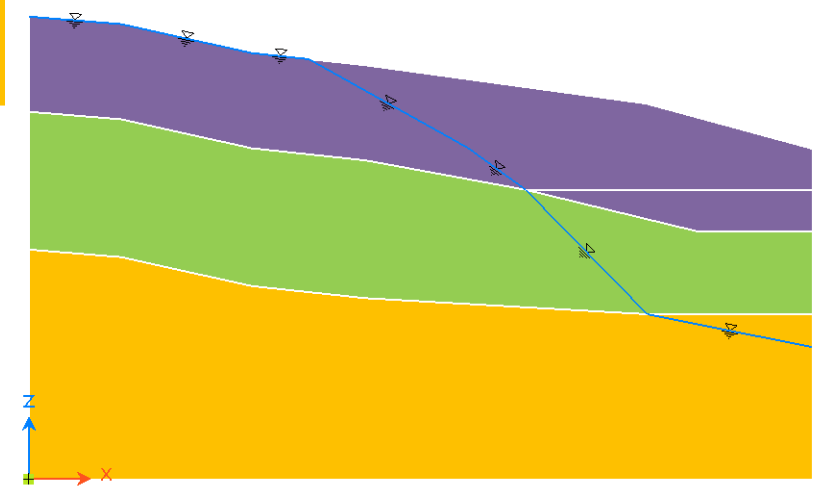
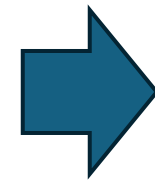
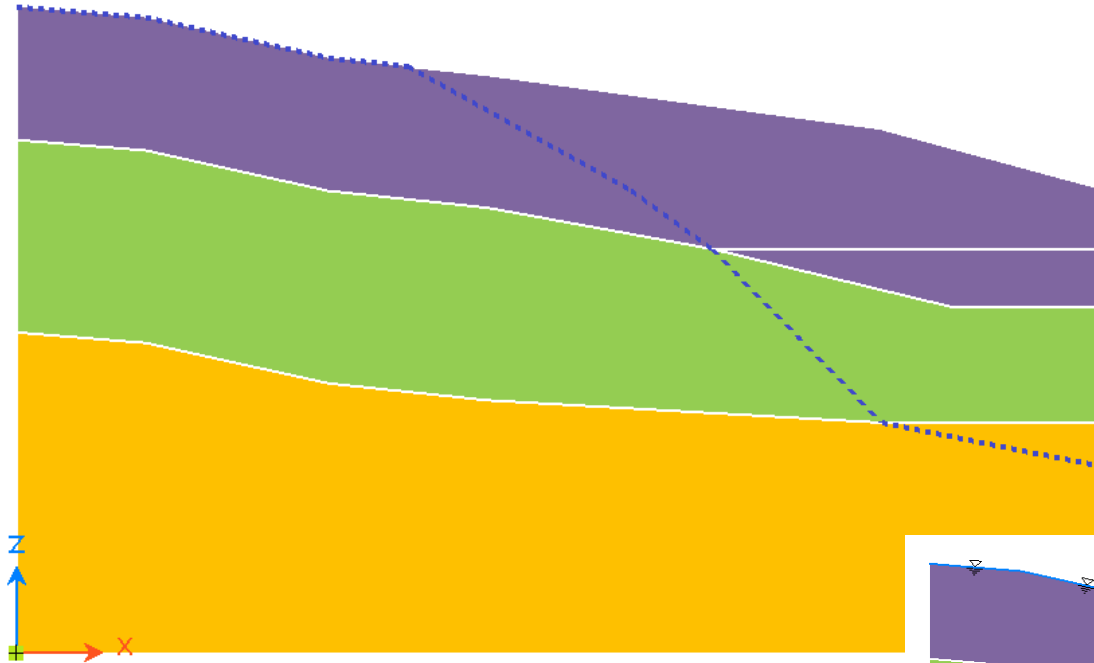
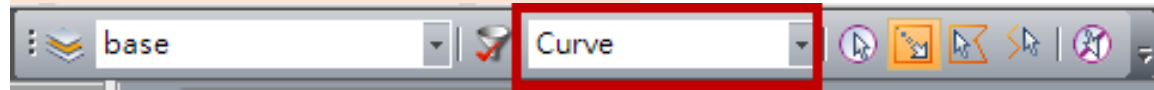

網格集名稱編輯

Select Filter 切換到 Mesh



點選網格集,按F2可以編輯名稱

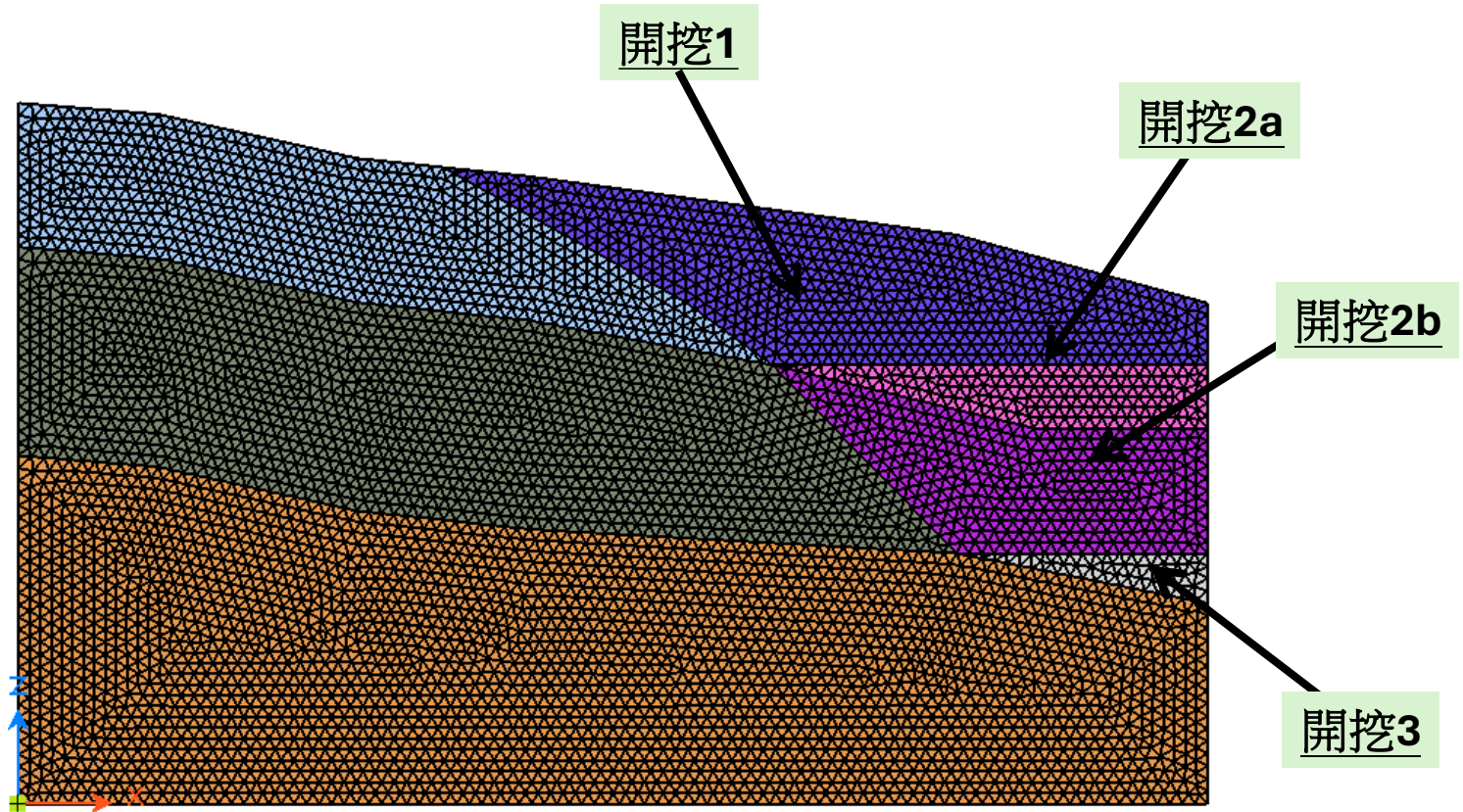
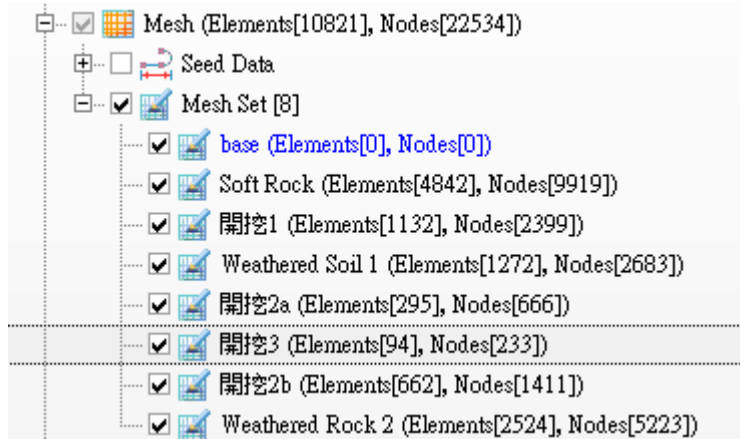

拘束條件

(自動判斷)

Loads | Boundaries 選單

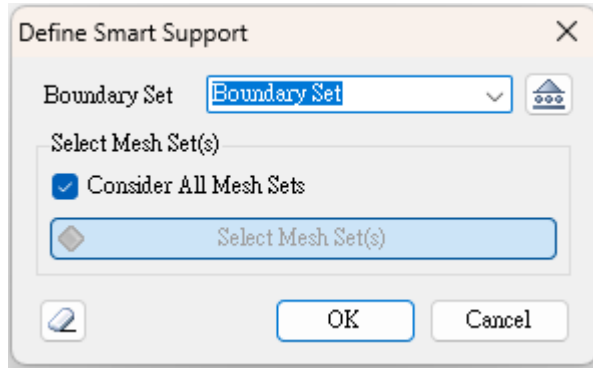

自動施加拘束條件

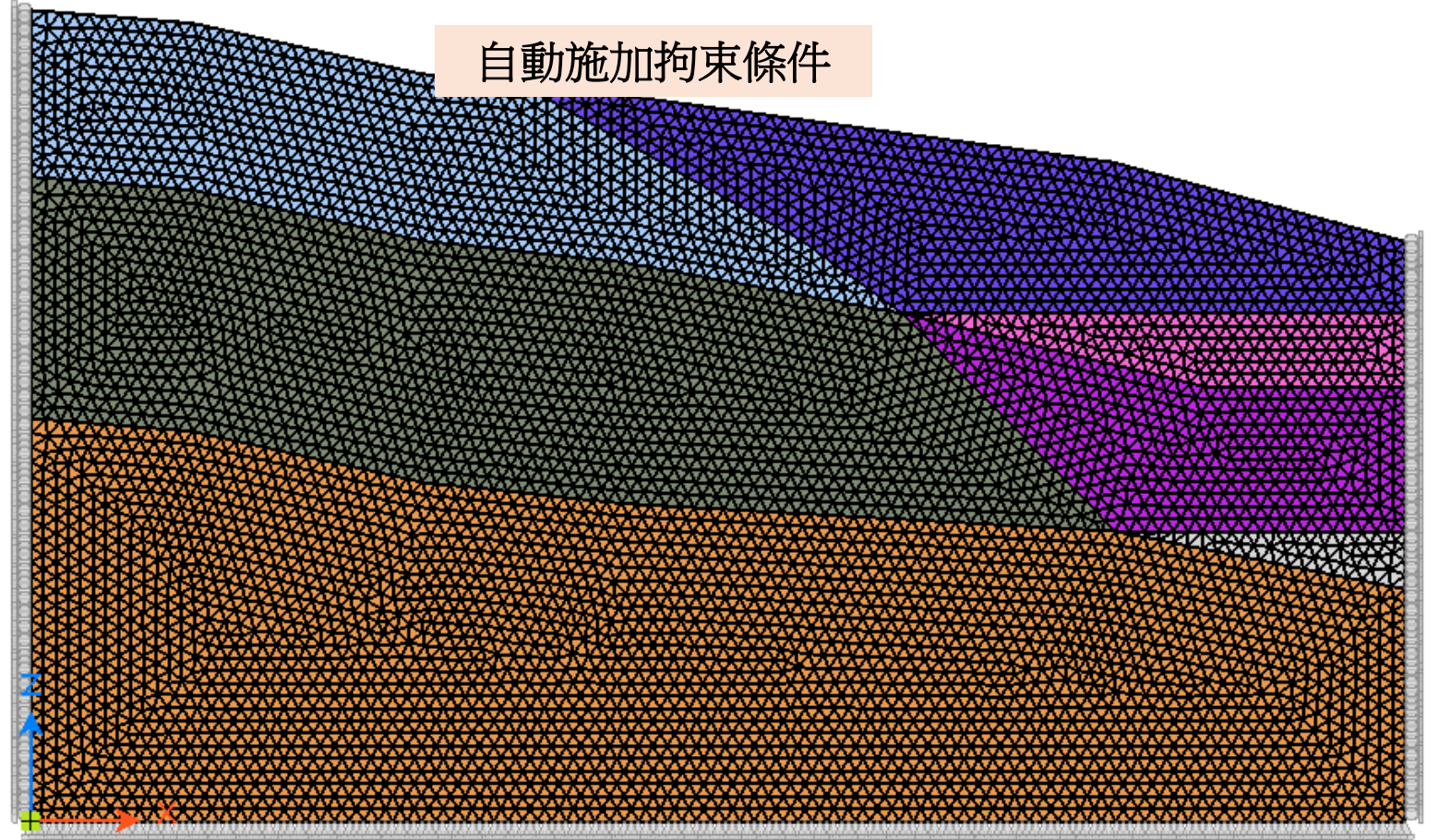



施工階段新增-1

(Stage0. Initial ~ Stage1. Excavation1)

Stage0. Initial

Define Construction Stages

Stage0. Initial

Construction Stage Data

Name: Stage0. Initial

Analysis Type: Strength Reduction Method (SF)

Partial Factor: None

Analysis Type : SRM

Water Level

0.000 m Water Level

Load Distr **水位線指定**

Initialize Displ

Undrained Condition

Add Modify

Define Construction Stage Analysis Model ... Close

Add新增施工階段

Stage1. Excavation1

Define Construction Stages

Stage1. Excavation1

Construction Stage Data

Name: Stage1. Excavation1

Analysis Type: Strength Reduction Method (SF)

Partial Factor: None

Analysis Type : SRM

Water Level

0.000 m Water Level

Load Distr **水位線指定**

Initial

Undrained Condition

Add Modify

Define Construction Stage Analysis Model ... Close

Add新增施工階段



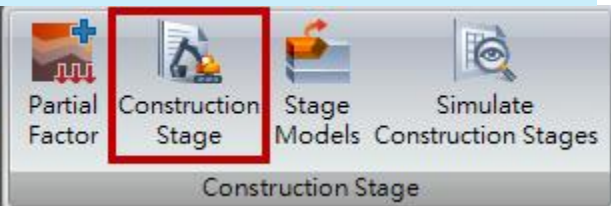

施工階段新增-1

(Stage2. Excavation2~ Stage3. Excavation3)

Stage2. Excavation2

Define Construction Stages

Stage2. Excavation2

Construction Stage Data

Name: Stage2. Excavation2

Analysis Type: Strength Reduction Method (SRM)

Partial Factor: None

Analysis Type : SRM

Water Level

0.000 m Water Level

Load Distribution

Initialize Displacement

Undrained Condition

水水位線指定

Add Modify

Define Construction Stage Analysis Model ... Close

Add新增施工階段

Stage3. Excavation3

Define Construction Stages

Stage3. Excavation3

Construction Stage Data

Name: Stage3. Excavation3

Analysis Type: Strength Reduction Method (SRM)

Partial Factor: None

Analysis Type : SRM

Water Level

0.000 m Water Level

Load Distribution

Initialize Displacement

Undrained Condition

水水位線指定

Add Modify

Define Construction Stage Analysis Model ... Close

Add新增施工階段





LEM 施工階段編輯-1

(Stage0. Initial)

開啟施工階段檢視

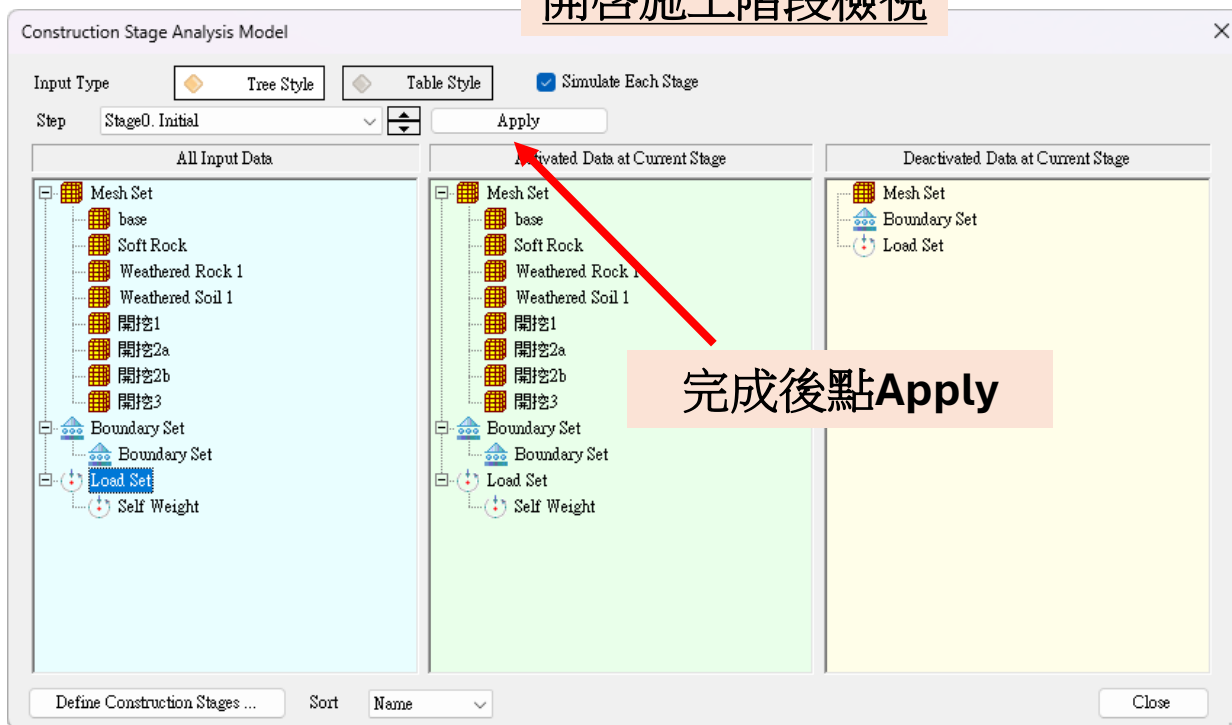

完成後點Apply

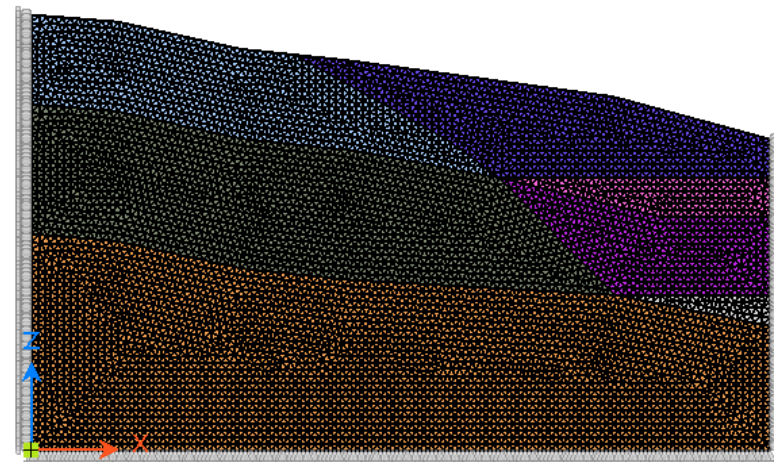

拖曳全部土壤(含開挖區域)網格集/邊界集/Self Weight 載荷集



LEM施工階段編輯-2

(Stage1. Excavation1 to Stage3. Excavation3)

Stage1. Excavation 1

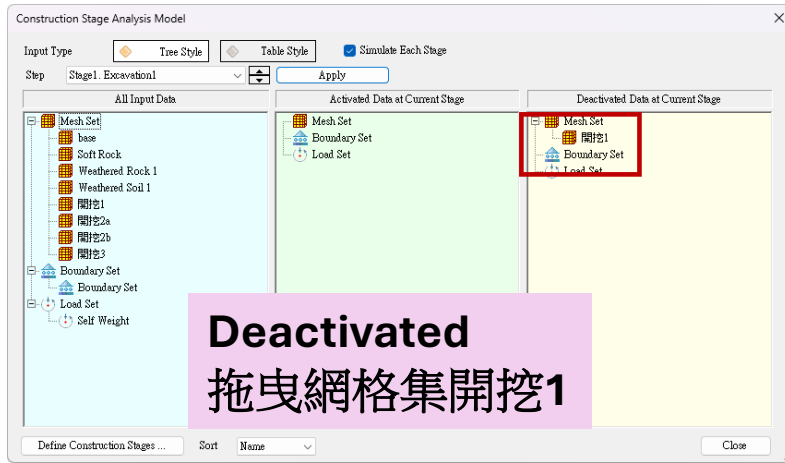

Stage2. Excavation 2

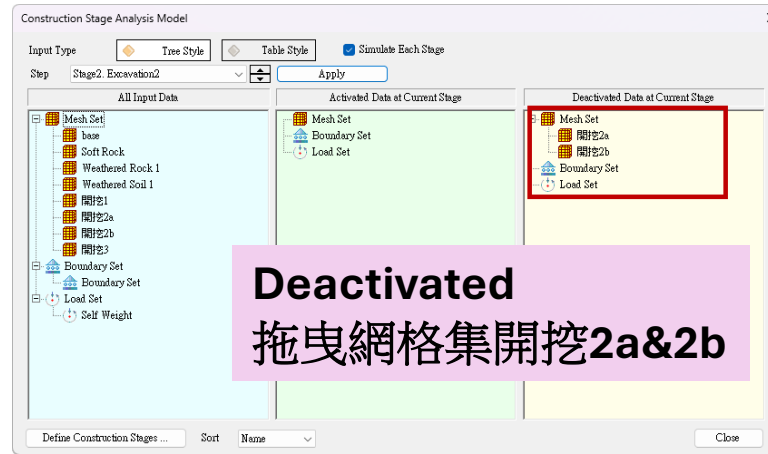

Stage3. Excavation 3

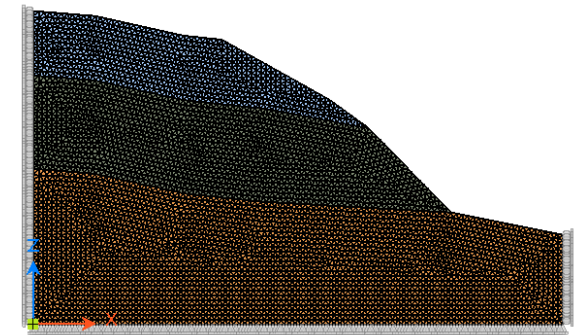
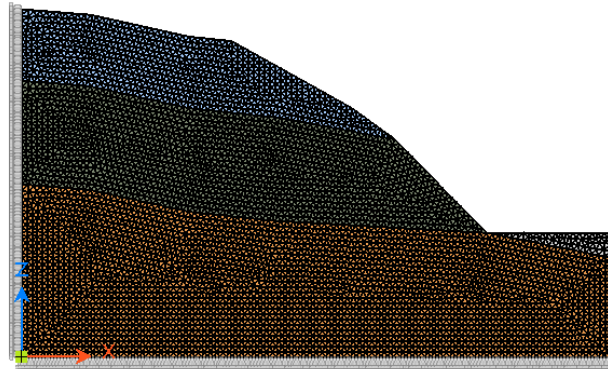
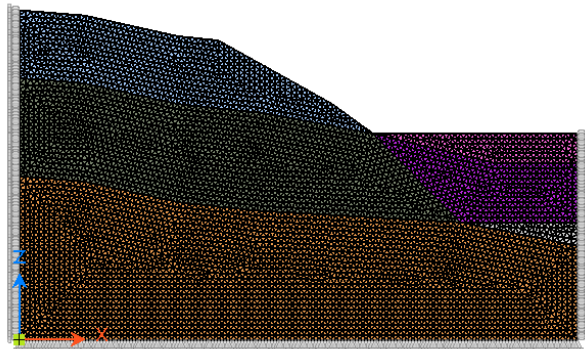
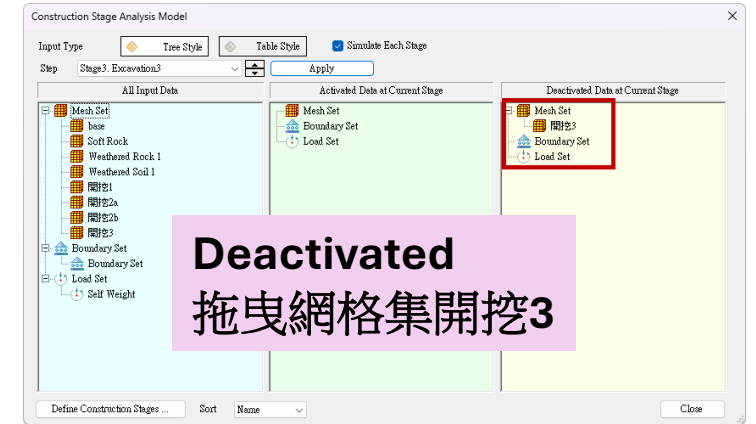

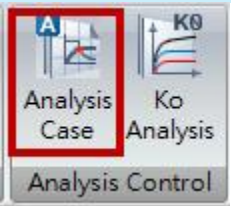

分析定義

(SRM邊坡穩定性分析)

分析名稱:SRM邊坡穩定性分析/分析類型:Construction Stage

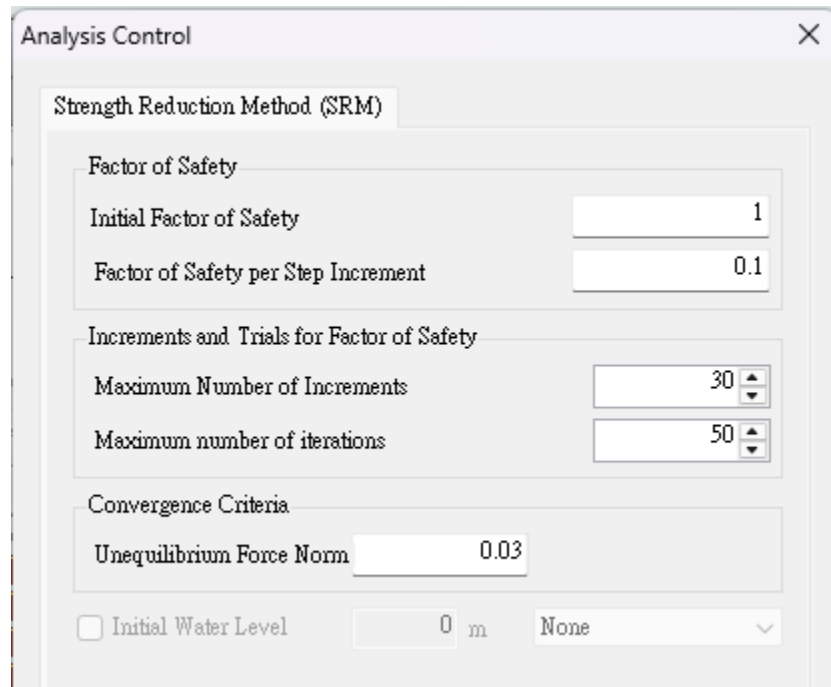
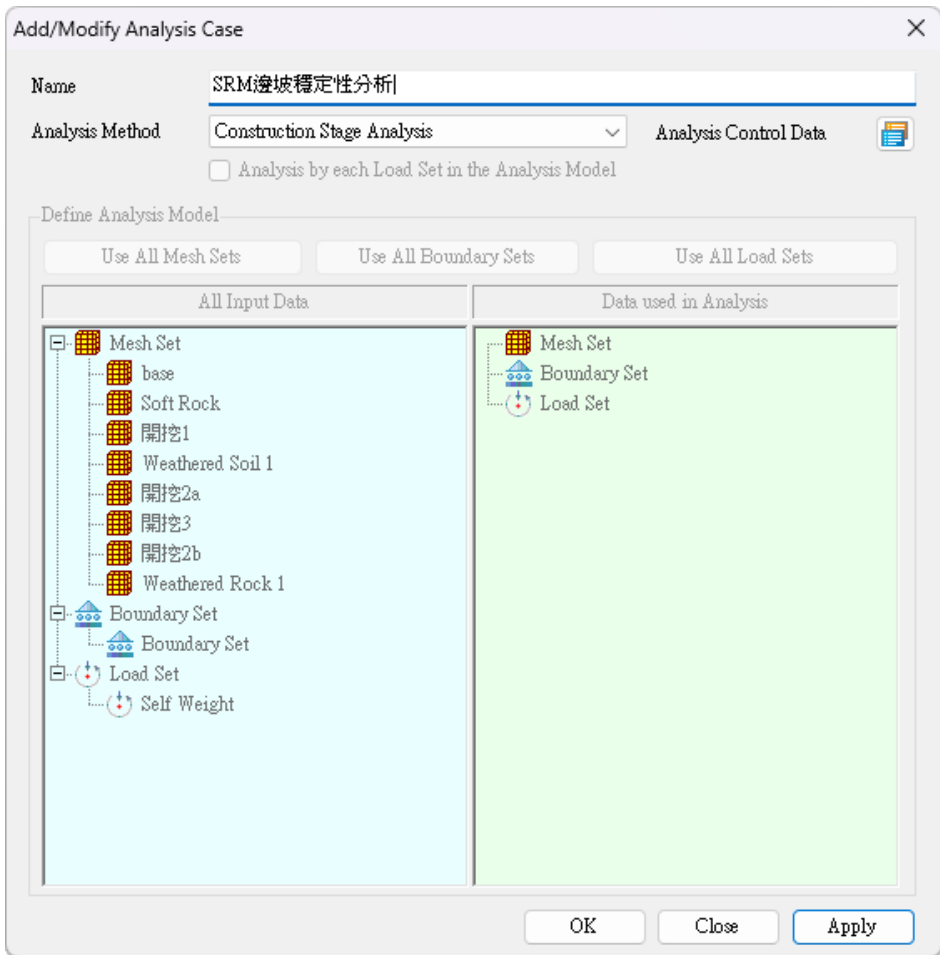
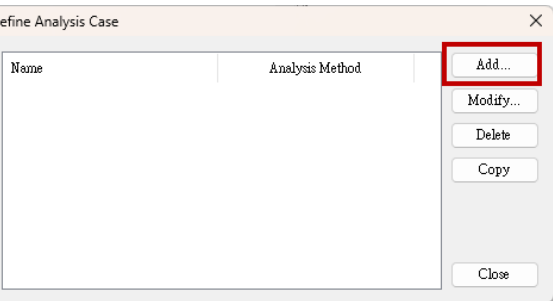

計算

The screenshot displays the SoilWorks software interface. The main window title is "SoilWorks - Soilworks_標準教學系列2_邊坡模組_1_SRM無加筋邊坡穩定分析 [Slope Module]". The menu bar includes "Geometry", "Limit Equilibrium Method", "Model", "Loads | Boundaries", "Analysis | Design", "Results", "Tools", and "Window". The toolbar contains various icons, with the "Analysis" icon highlighted by a red box. A blue callout box with the text "執行求解" (Execute Solution) points to this icon.

The "Analysis Manager" dialog box is open, showing a table of analysis cases:

<input checked="" type="checkbox"/>	<input checked="" type="checkbox"/>	Name	Analysis Type
<input checked="" type="checkbox"/>	<input checked="" type="checkbox"/>	SRM邊坡穩定性分析	Construction Stage Analysis

Below the table, a blue callout box with the text "計算迭代過程" (Calculation Iteration Process) is visible. At the bottom of the dialog box, the "Perform Analysis" button is highlighted with a red box.

The background shows a 3D model of a slope with a mesh. A coordinate system is visible at the bottom left of the model.

The "Message" window at the bottom right shows the following log:

```
Perform Construction Stage Model data (Number=1) has been generated.  
Command : STAGEMODEL  
Perform Analysis Case data (Number=1) has been generated.  
Command : ANALYSISCASE  
Command : RUNANALYSIS
```



依照施工階段定義順序
輸出結果

SRM分析結果

SRM透過水平變形和最大剪切應變判斷破壞面

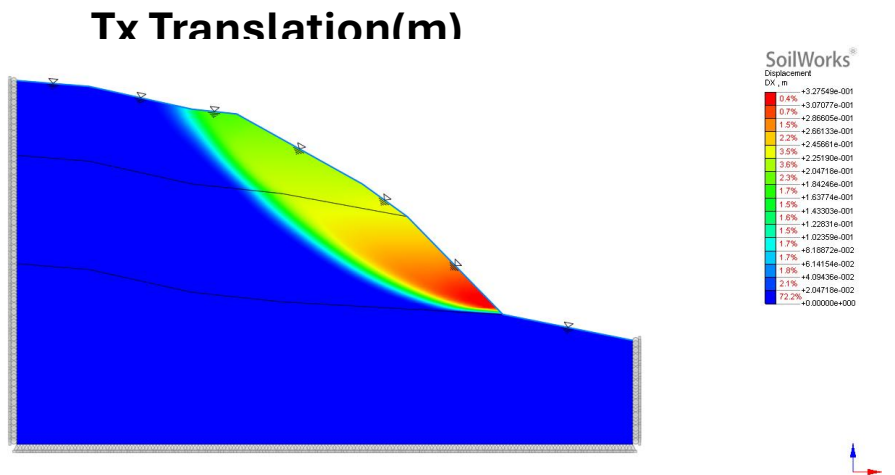
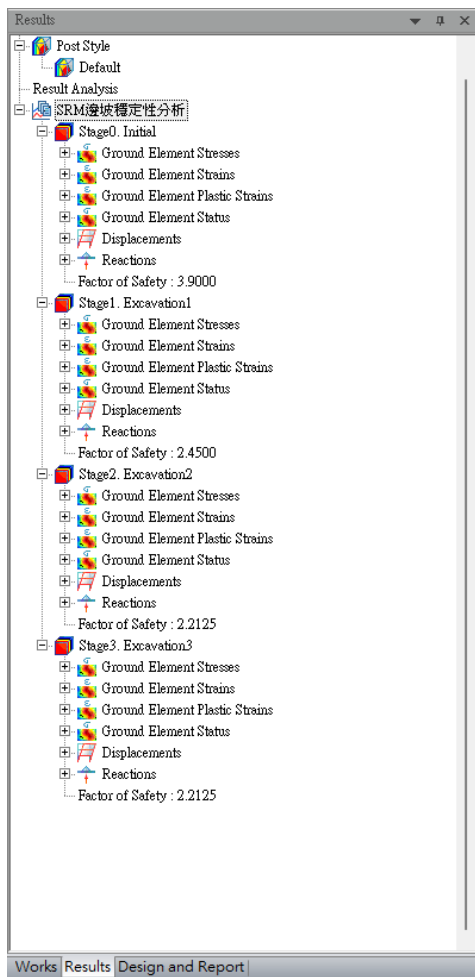

Maximum Shear Strain

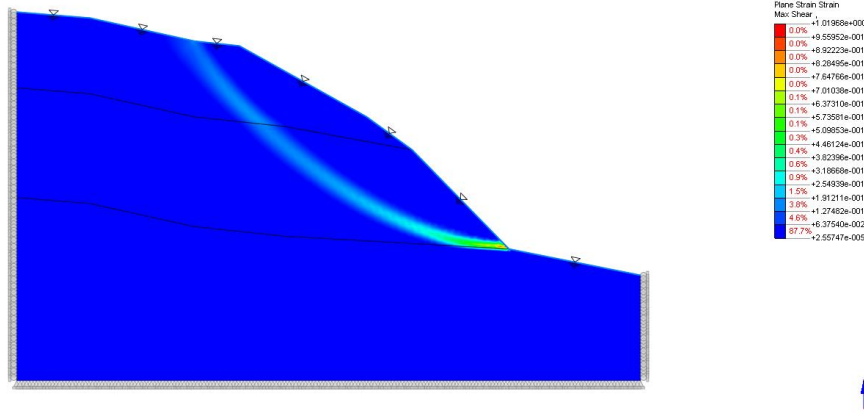

程式會自動輸出安全係數



Soilworks_標準教學系列

土釘加勁邊坡穩定分析



邊坡穩定分析

填築邊坡、開挖邊坡的穩定分析是大地工程分析中常見的分析內容，邊坡的自重、孔隙水壓、附加載重、地震作用、波動水壓力載重對邊坡的穩定影響很大。

當自重和外力作用下，邊坡內部的剪應力大於邊坡岩土所具有的剪力強度時，邊坡將發生破壞。所以通過剪應力和剪力強度的分析來計算邊坡的穩定性的分析叫做邊坡穩定分析。

- **Soilworks /GTS NX**
 - Limit Equilibrium Method(LEM)-極限平衡法 2D
 - Stress Analysis Method (SAM)-應力分析法 2D
 - Strength Reduction Method (SRM)-強度折減法 2D/3D

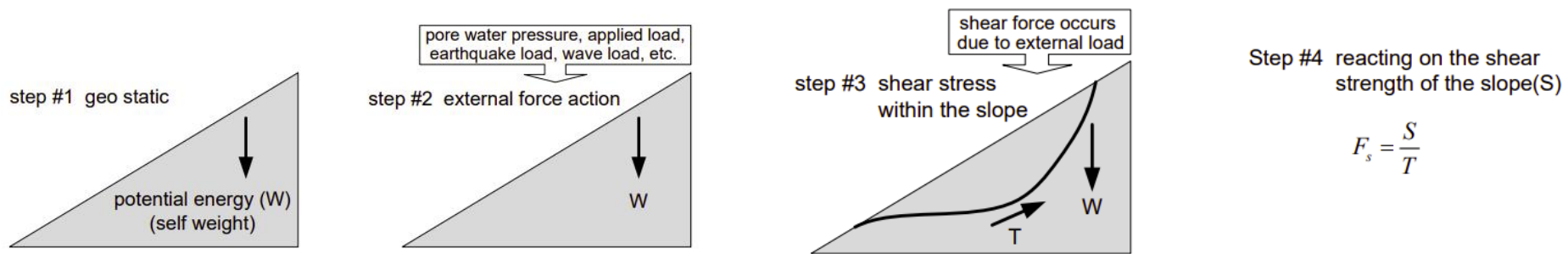

Reference

GTS NX/FEA NX/Soilworks Manual



Agenda

- **Part1.LEM**土釘加勁邊坡穩定分析
(Limit Equilibrium Method(LEM)-極限平衡法)
- **Part2.SRM**土釘加勁邊坡穩定分析
(Strength Reduction Method (SRM)-強度折減法)
- **Part3.SAM**土釘加勁邊坡穩定分析
(Stress Analysis Method (SAM)-應力分析法)



Part1. LEM土釘加勁邊坡穩定分析

(Limit Equilibrium Method(LEM)-極限平衡法)



Limit Equilibrium Method(LEM)

(極限平衡法)

極限平衡法(LEM)，計算滑動面位置相對於地表質量的力和力矩的平衡。基於此觀念，沿著假設的直線、圓弧或不規則的滑動面符合莫爾-庫侖破壞準則，計算在滑動面破壞時刻時的穩定性，透過兩個主要材料參數評估的破壞表面內聚力(c)和內摩擦角(ϕ)。

The simplified Bishop method

由於其簡單性和相對精確度，在各種切片方法中應用最為廣泛。安全係數(F)需要透過迭代過程和試誤法來計算。

$$F = \frac{1}{\sum W \sin \alpha} \sum \left[\{c' l \cos \alpha + (W - ul \cos \alpha) \tan \phi'\} \left\{ \frac{1}{m_\alpha} \right\} \right]$$

$$\text{where, } m_\alpha = \cos \alpha \left(1 + \frac{\tan \alpha \tan \phi}{F} \right)$$

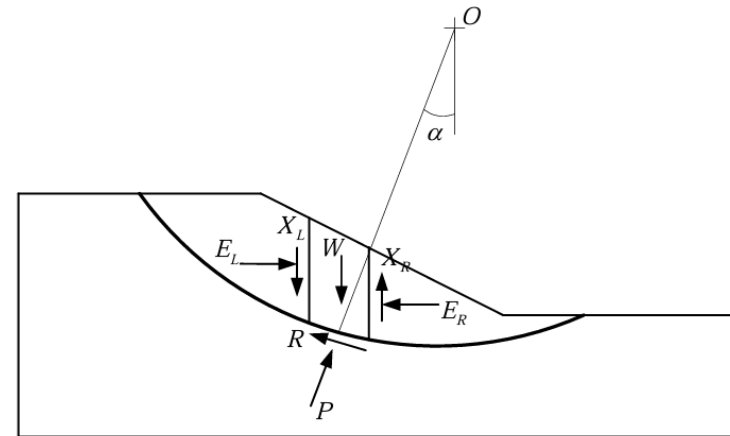
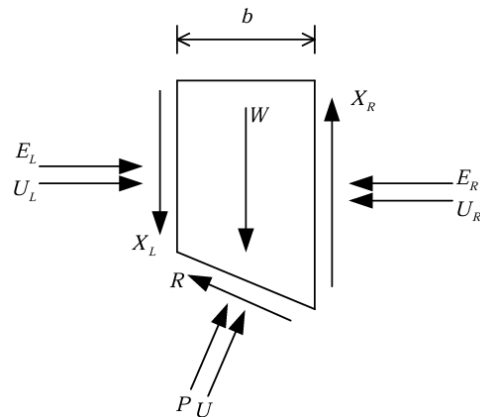

Reference

GTS NX/FEA NX/Soilworks Manual



邊坡(Slope)模組



選擇邊坡(Slope)模組

Limit Equilibrium Method(LEM)-極限平衡法

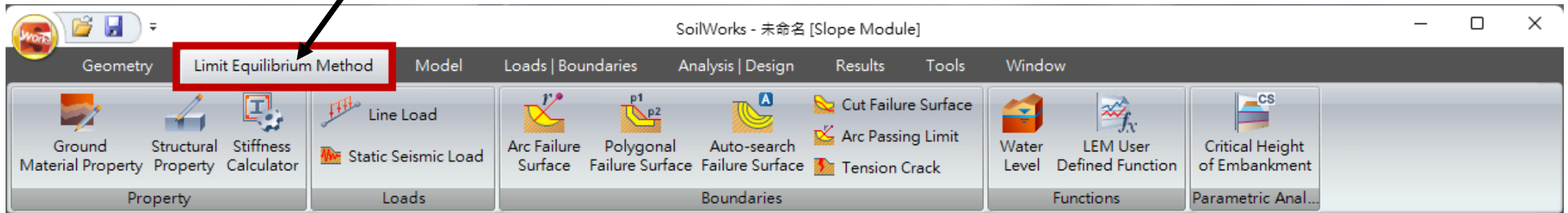

單位切換

The screenshot displays the MIDAS Gen software interface. The main window shows a project tree on the left and a central workspace. Two dialog boxes are open:

- Define Initial Parameters:** A dialog box with a title bar "Define Initial Parameters". It has tabs for "Unit System", "Force", "Length", "m", and "Time", "sec". Under "Unit System", "SI", "CGS", "FPS", and "User Defined ..." are listed. The "Initial Parameters" section includes:
 - Gravitational Acceleration: 9.807 m/sec²
 - Unit Weight of Water: 9.807 kN/m³
 - Initial Temperature: 0.000 [T]Buttons for "Project Information..." and "OK" are at the bottom.
- Unit settings:** A dialog box titled "Unit settings" with a close button (X). It has three columns:
 - Force Unit [F]:** Radio buttons for kgf, tonf, N, **kN** (selected), lbf, kips.
 - Length Unit [L]:** Radio buttons for **m** (selected), cm, mm, ft, inch.
 - Time Unit [T]:** Radio buttons for **sec** (selected), min, hour, day.Buttons for "Reset", "OK", and "Cancel" are at the bottom.

A 3D coordinate system with X, Y, and Z axes is visible in the workspace.



DWG模型匯入

Import>CAD File

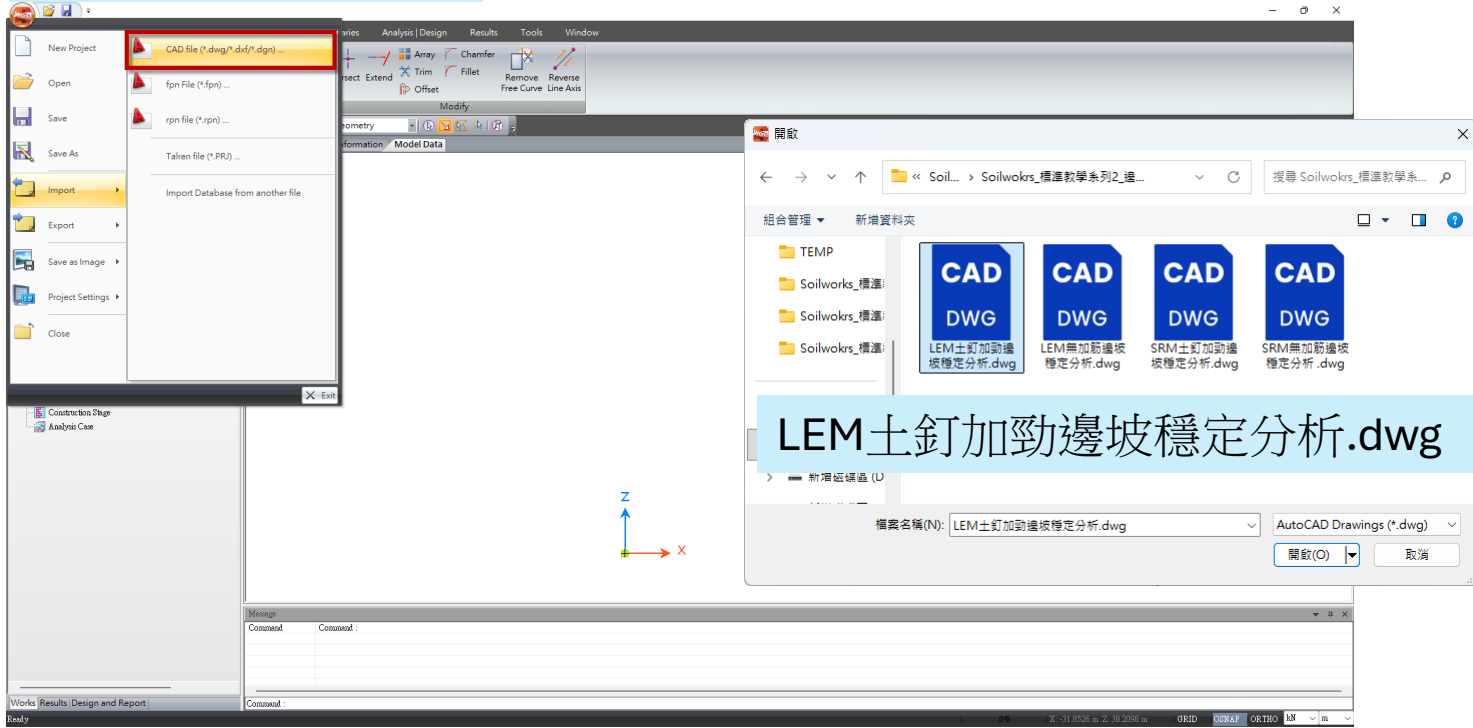

LEM土釘加勁邊坡穩定分析.dwg

匯入後線特徵模型

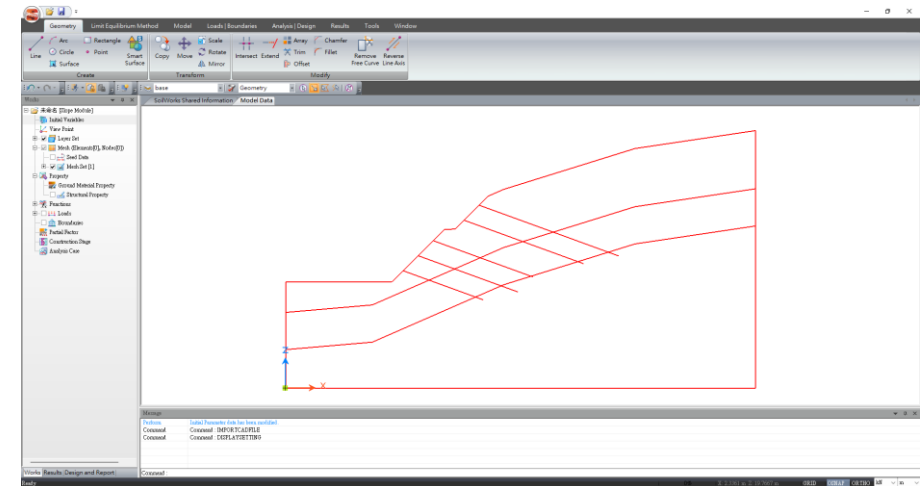
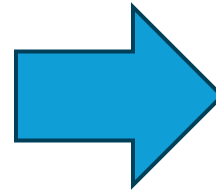

新增土釘圖層

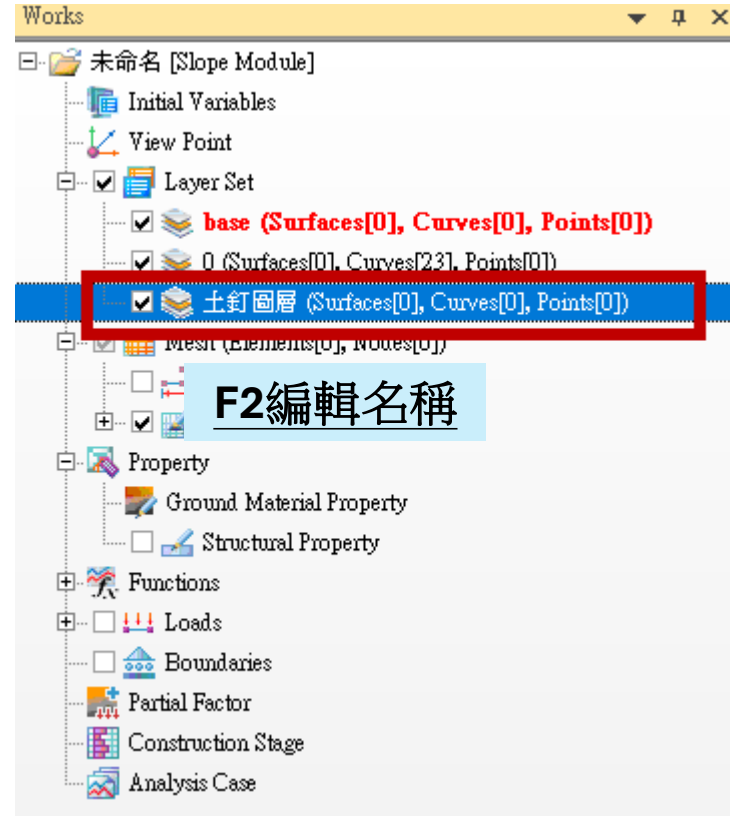
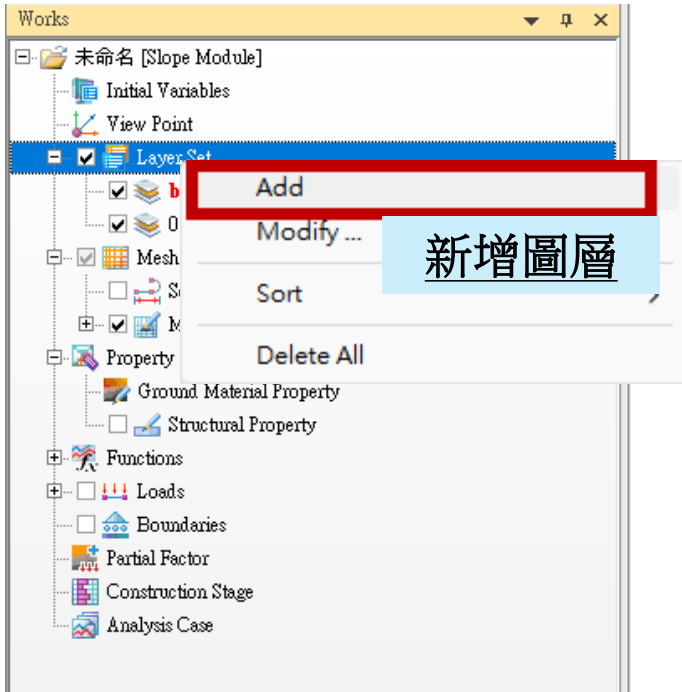

土釘圖層編輯

Select Filter 切換到 Curve

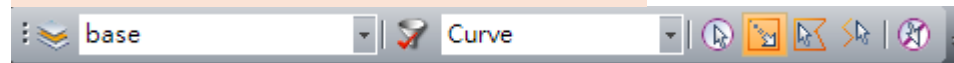

移動土釘特徵到土釘圖層

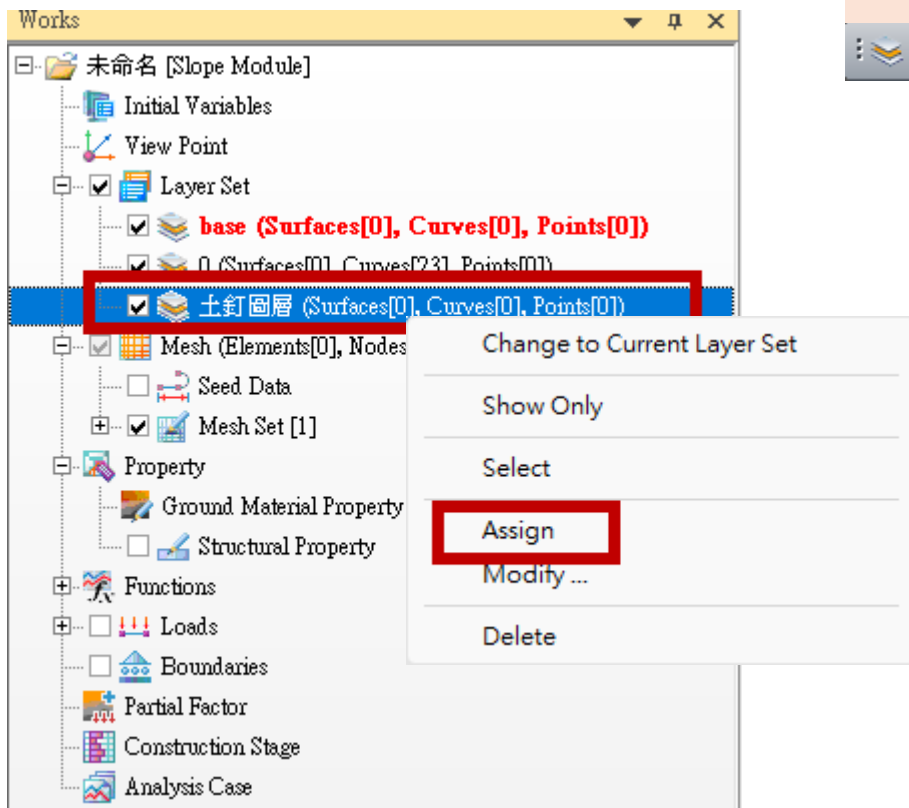
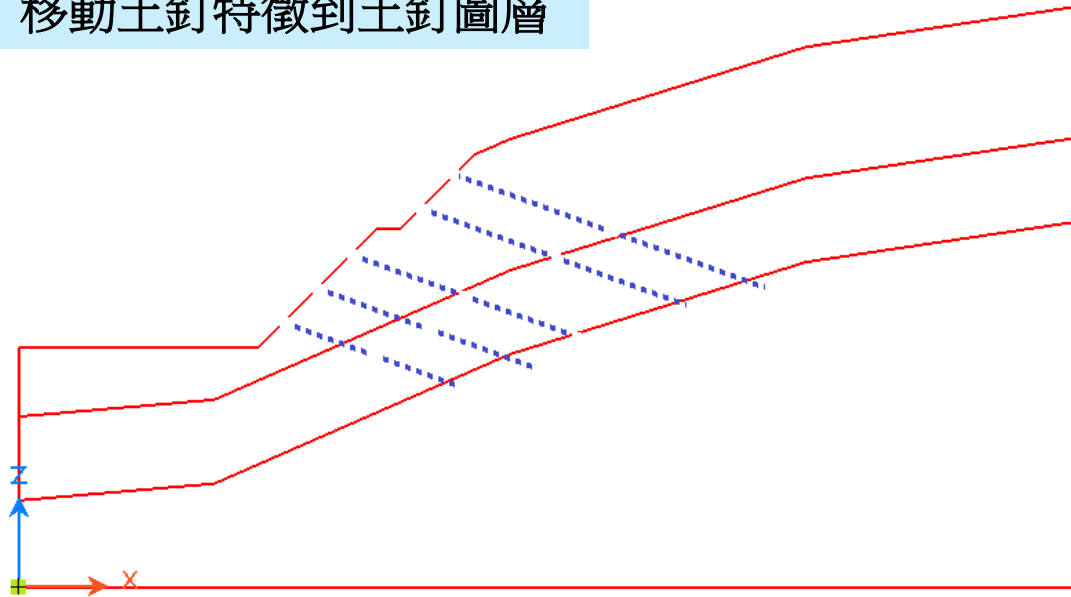

Geometry 選單>Smart Surface

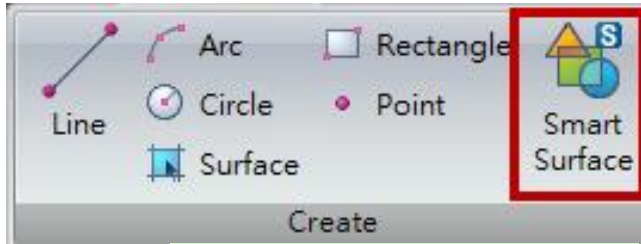

自動生成面特徵

隱藏土釘圖層

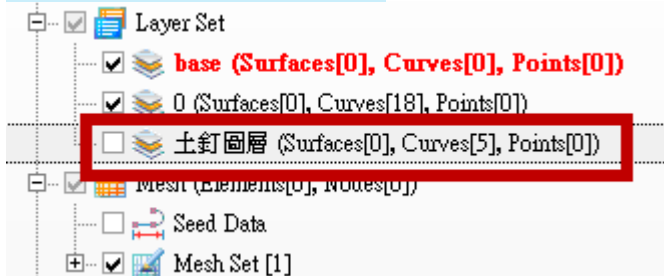

面特徵建立

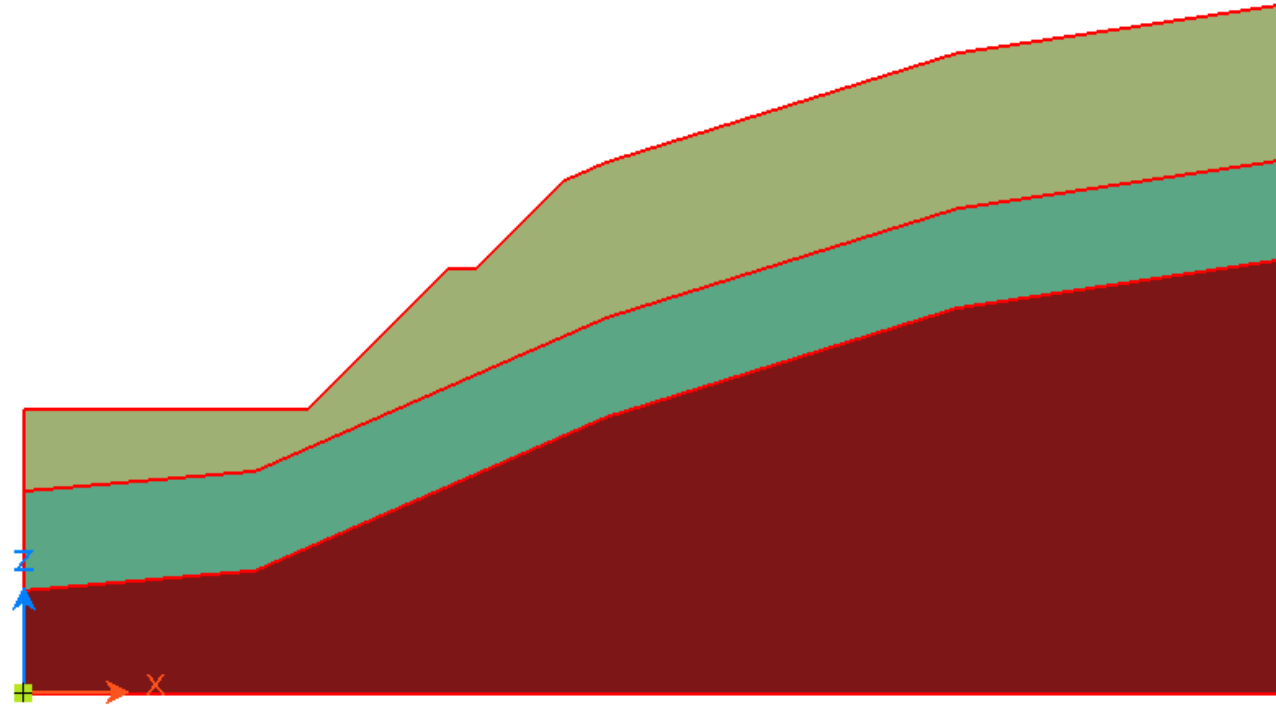

Layer Color(顏色顯示方式)

LEM土壤材料屬性(Soilworks材料庫)

Limit Equilibrium Method

選取 1.1schist#1 類別

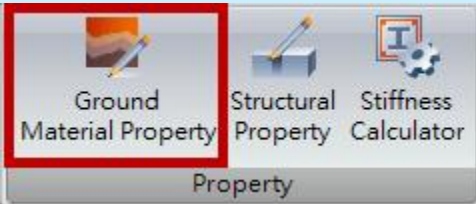

Define Ground Material Property

Data

ID	Name
1	

General

ID 1 Name

Model Type Mohr-Coulomb

General Parameters

Modulus of Elasticity (E)	20000000	kN/m ²
Poisson's Ratio (ν)	0.3	
Temperature Coeff. (α)	1E-06	
Unit Weight (γ)	20	kN/m ³
Saturated Unit Weight	21	kN/m ³
Cohesion (c)	30	kN/m ²
Internal Friction Angle (Φ)	36	[deg]
Earth Pressure Coeff. (K ₀)	1	
Draining Condition	Drained	

Additional Parameters

Variation in Modulus of Elasticity	0	kN/m ²
Variation in Cohesion	0	kN/m ²
Reference Height	0	m
<input type="checkbox"/> Dilatancy Angle (ψ)	36	[deg]
<input type="checkbox"/> Tensile Strength	2000	kN/m ²

Database ... Material Statistic Add Modify Delete Close

Ground Material Database

Database 1.1 Schist#1

Select All Unselect All

No.	Soil Type	Modulus of Elasticity (kN/m ²)	Unit Weight (kN/m ³)	Saturated Unit Weight (kN/m ³)	Poisson's Ratio	Cohesion (kN/m ²)	Internal Friction Angle	Select
1	Landfill Layer	13000	18	19	0.33	0	27	<input type="checkbox"/>
2	Alluvial Layer	8000	17	18	0.35	15	20	<input type="checkbox"/>
3	Weathered Soil	36500	18.5	19.5	0.33	17.5	31	<input checked="" type="checkbox"/>
4	Weathered Ro	150000	21	22	0.3	50	33	<input checked="" type="checkbox"/>
5	Soft Rock	1850000	24	25	0.28	180	35.5	<input checked="" type="checkbox"/>
6	Hard Rock	17500000	26	27	0.23	1750	40.5	<input type="checkbox"/>

選取 No3~No5

材料切換成Mohr-Coulomb(LEM)

Reset Save Model Type Mohr-Coulomb (LEM) Assign Close

Assign新增材料

完成LEM土壤材料新增

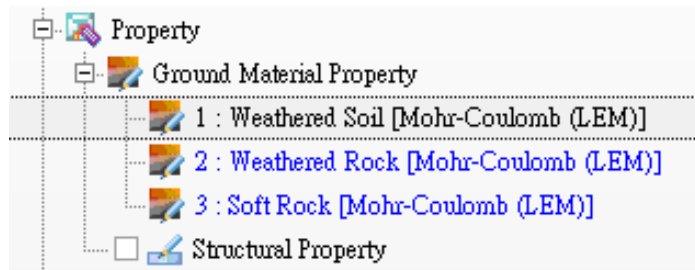

Soilworks材料庫



顏色顯示(補充)

自訂屬性顏色

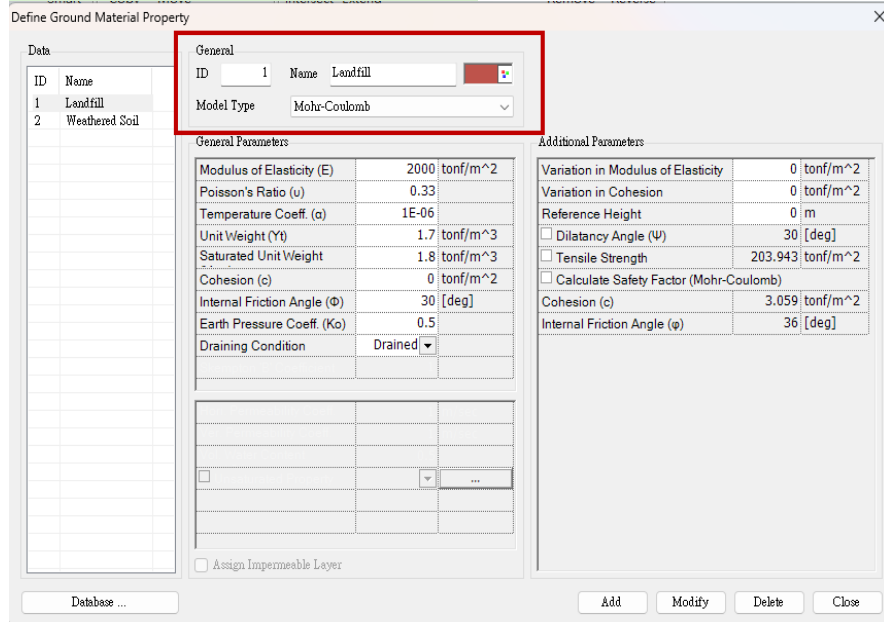

Display Setting顯示設定

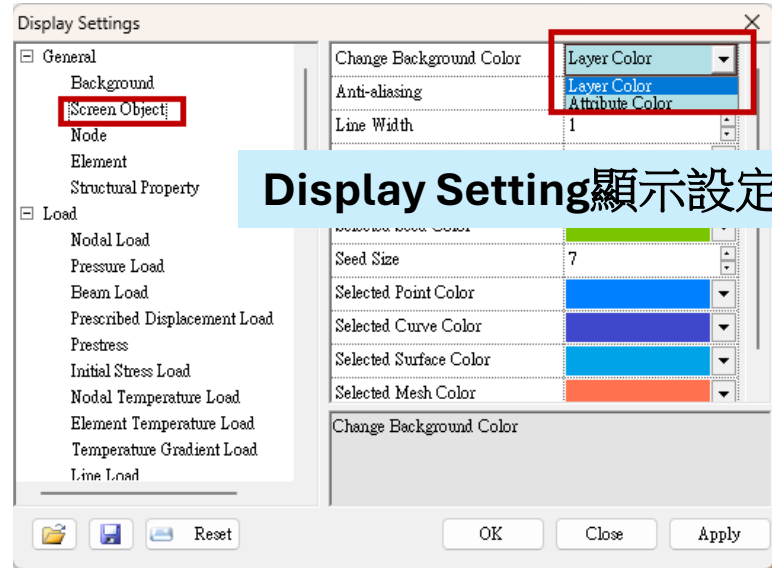

Display Setting顯示設定

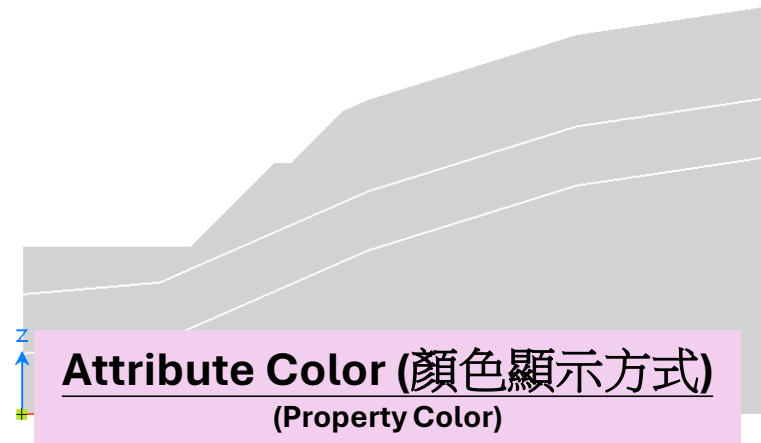

土壤材料屬性指定

Select Filter 切換到 Surface

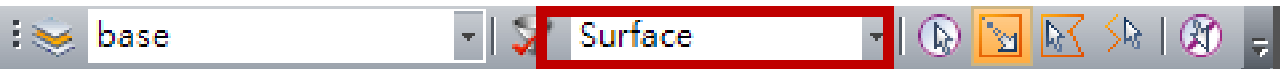

框選 Weathered Soil 分布區域特徵

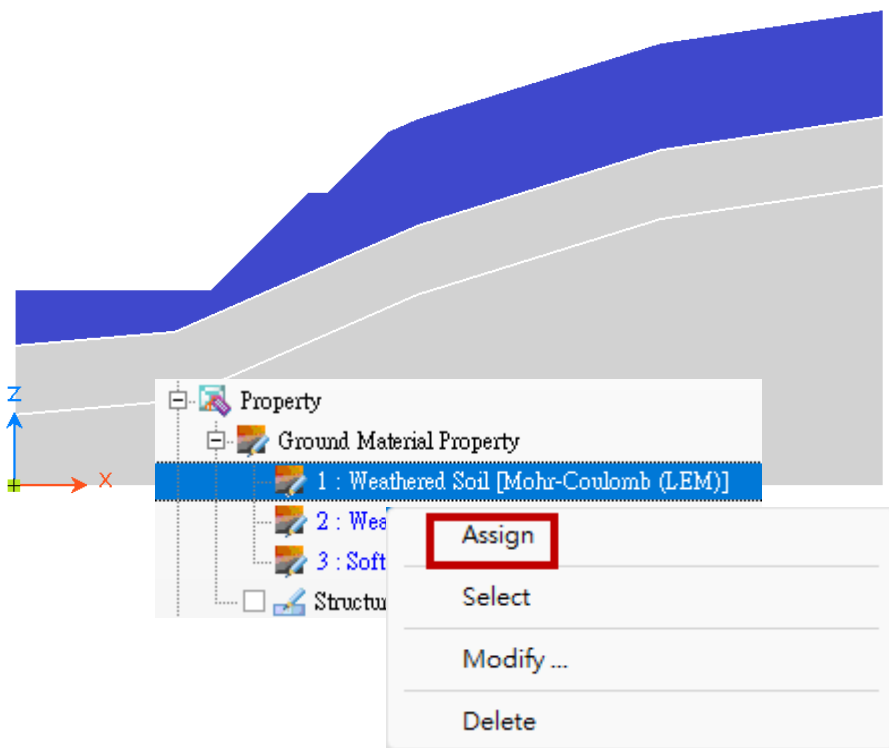

框選 Weathered Rock 分布區域特徵

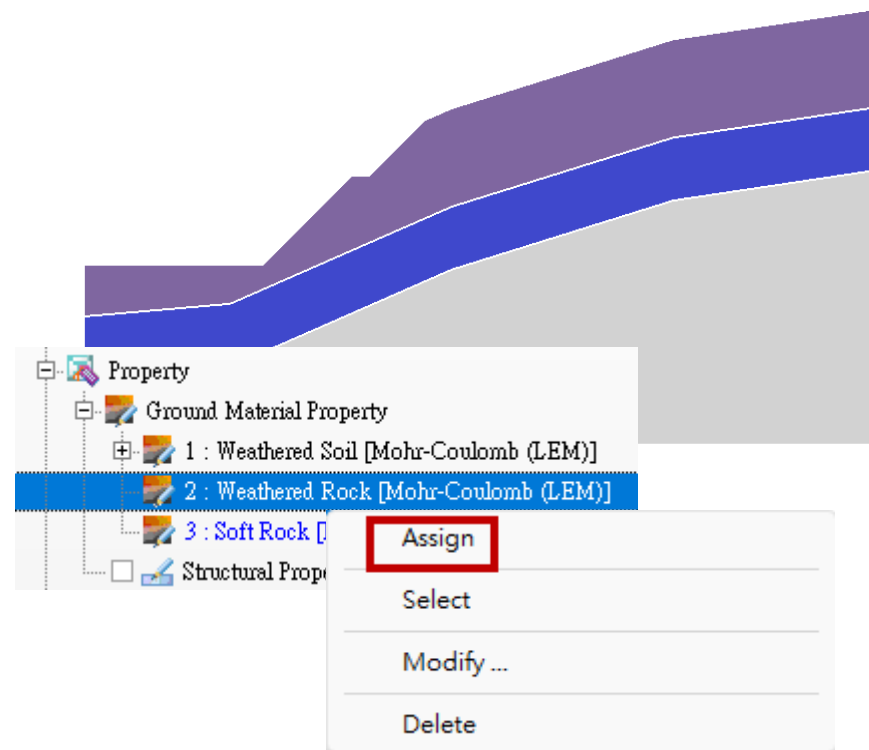

土壤材料屬性指定

Select Filter 切換到 Surface

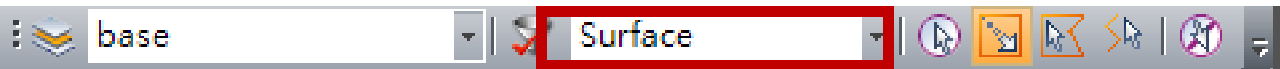

框選 Soft Rock 分布區域特徵

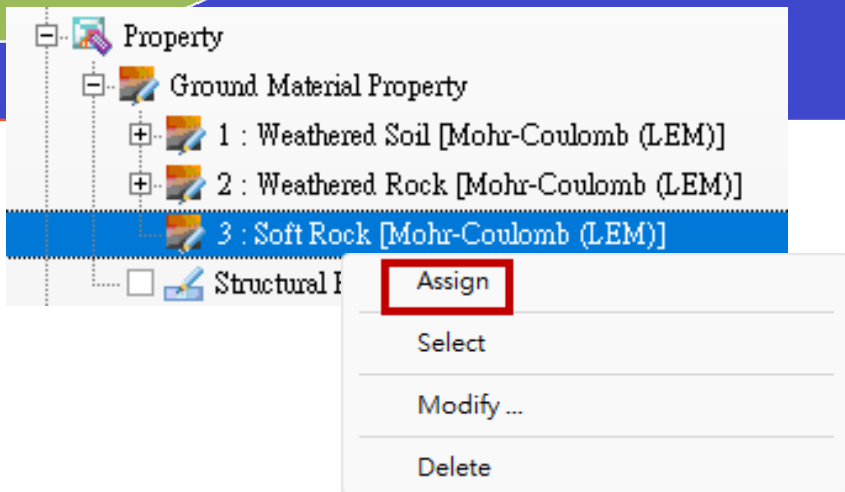
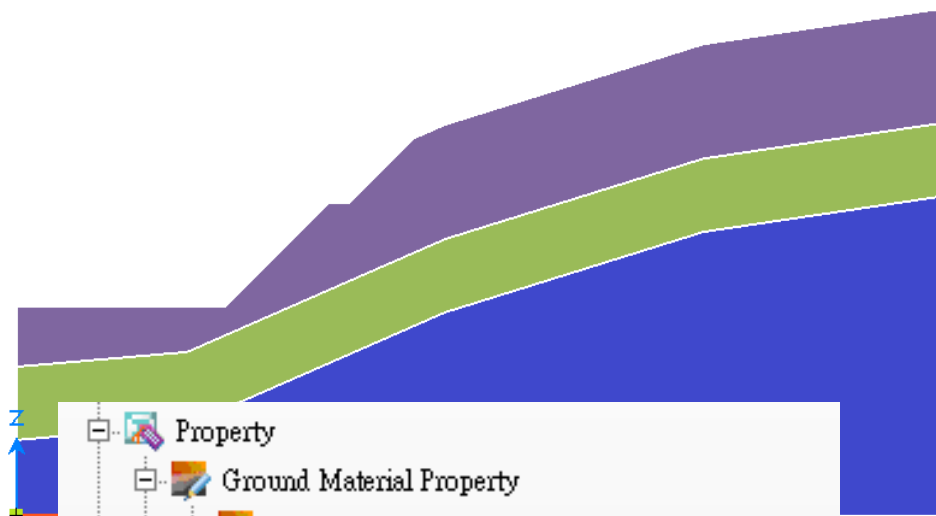

Ground Material Property 模型樹顯示指定特徵數量

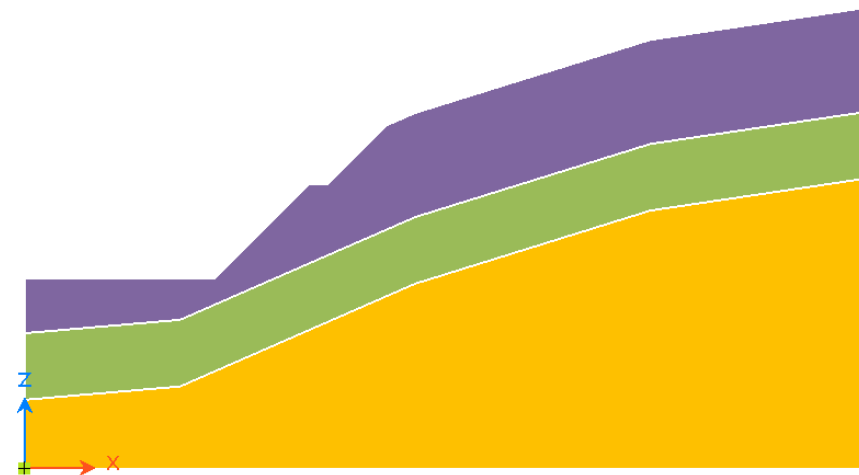
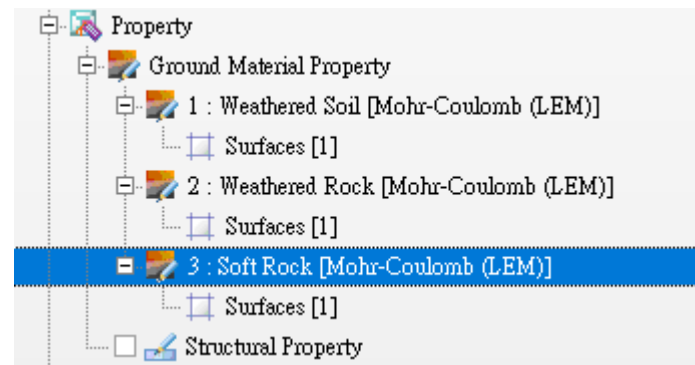

水位線

Limit Equilibrium Method

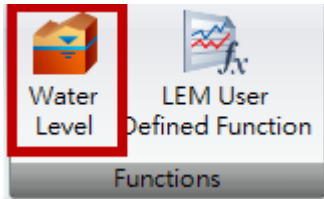

Water Level

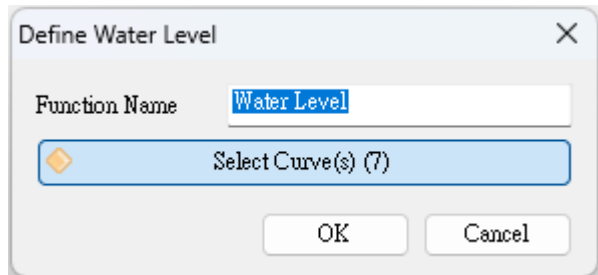

Select Filter 切换到 Curve

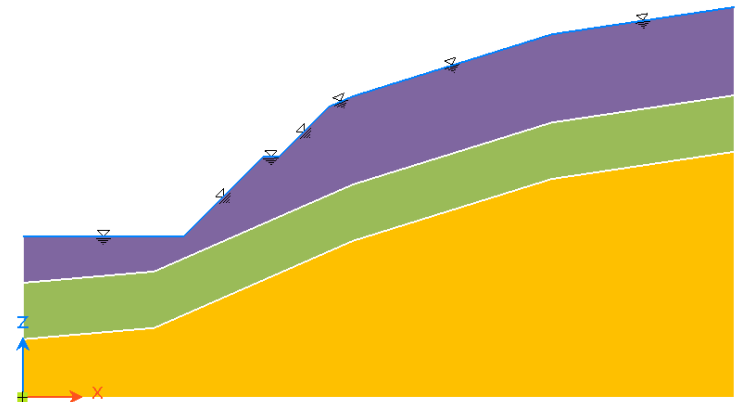
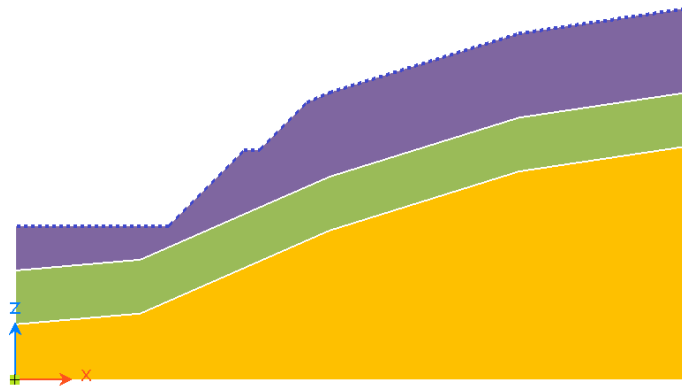
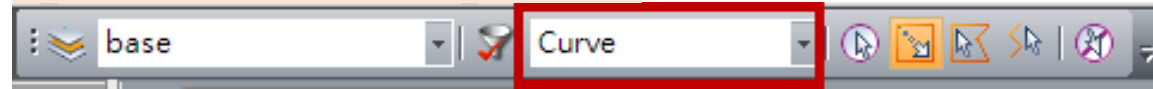

Limit Equilibrium Method

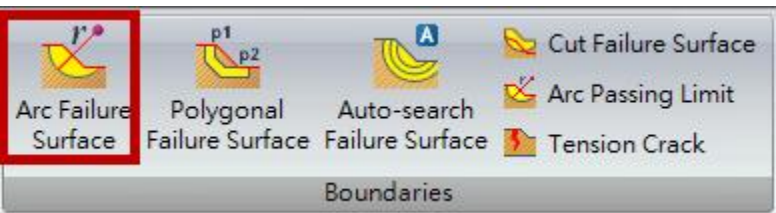

破壞面-1

(Arc Failure Surface-Grid Data)

自訂Boundary Set名稱:LEM破壞面

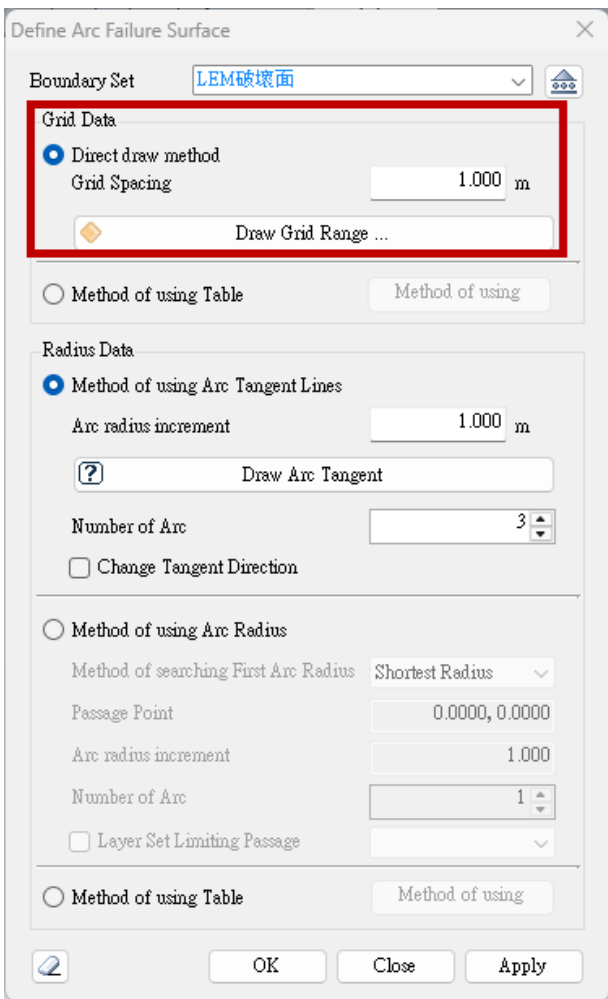

Grid Data

圓弧中心區域定義

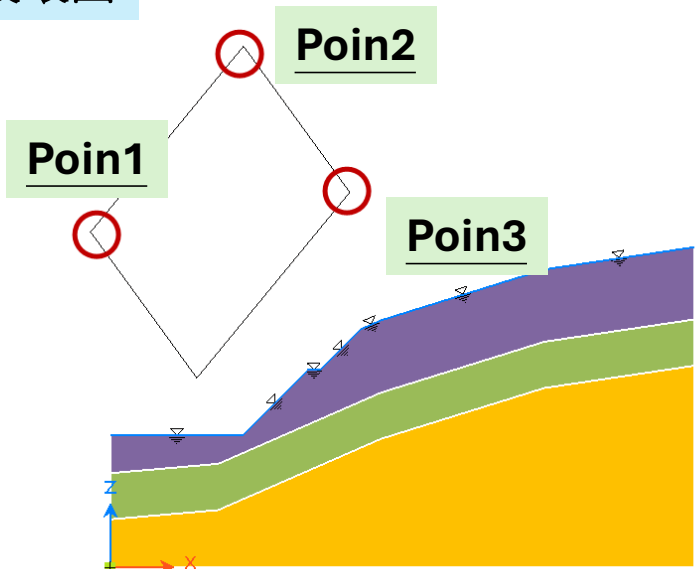

Draw Grid Range
依照順序空間點選Point1~Point3

預設節點間隔(1m)

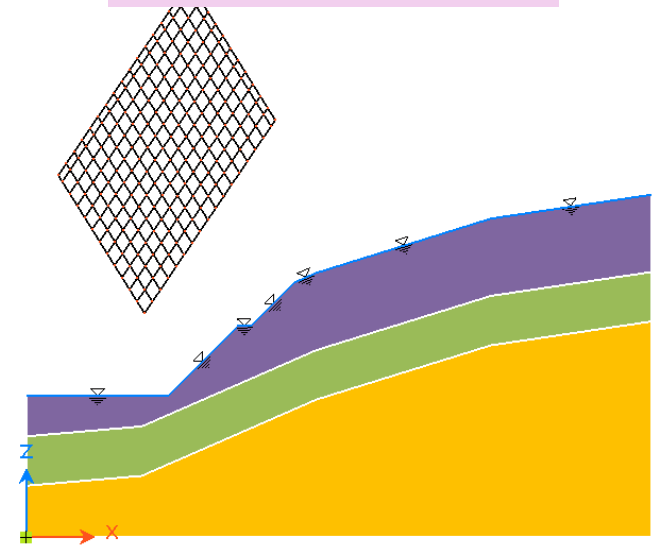

破壞面-2

(Arc Failure Surface-Radius Data)

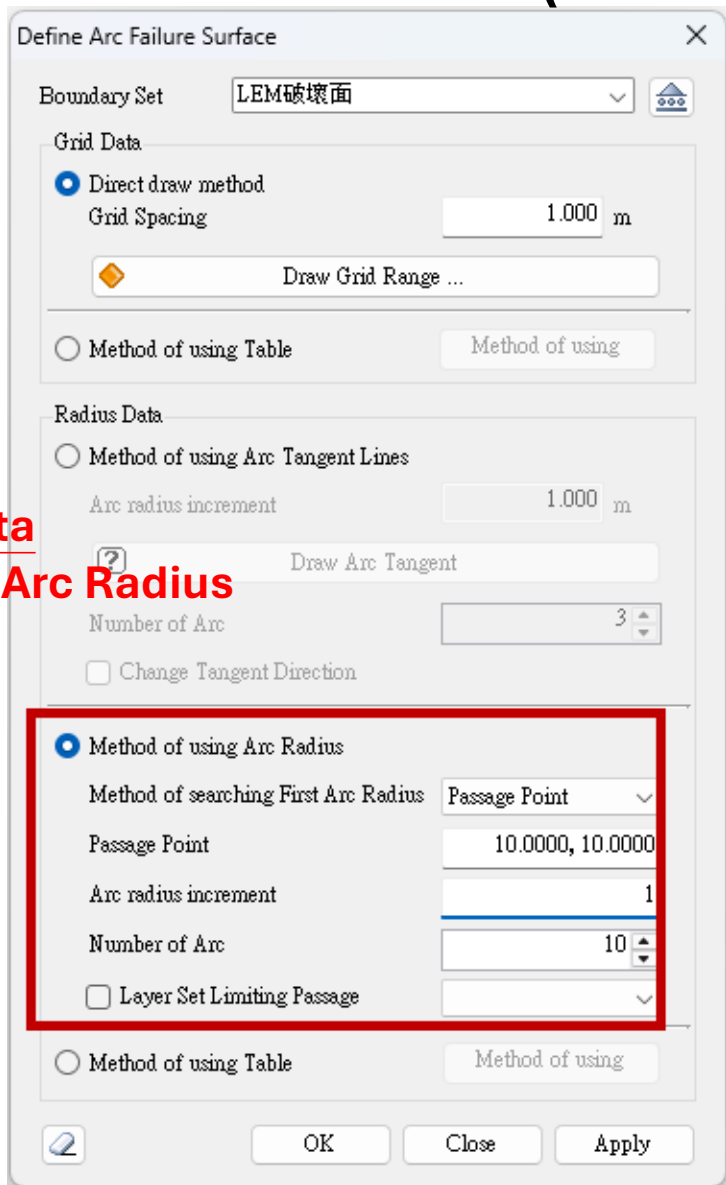

Radius Data
Method of Arc Radius

破壞面區域定義

預設採Arc Tangent Method

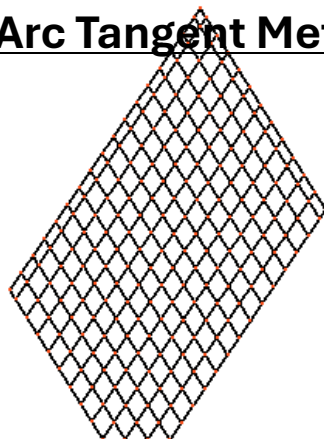

passage point

調整圓弧數(10)

預設圓弧間隔(1m)

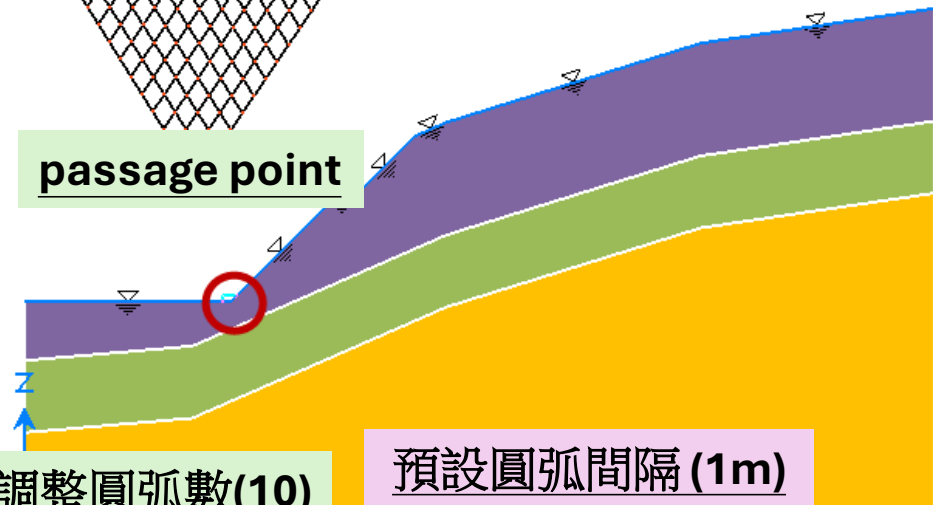

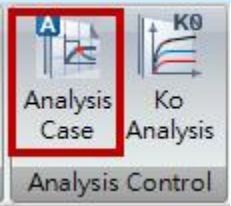

分析定義 (LEM邊坡穩定性分析)

分析名稱: LEM邊坡穩定分析/分析類型: Limit Equilibrium Method(LEM)

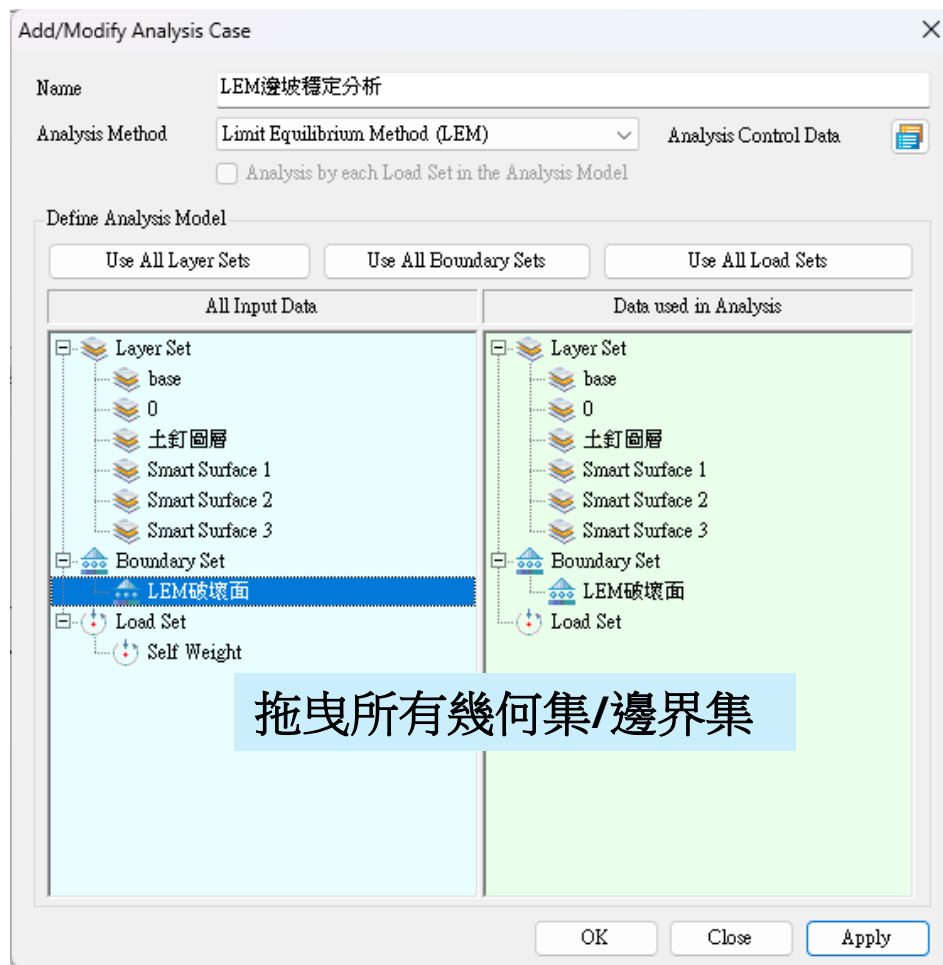
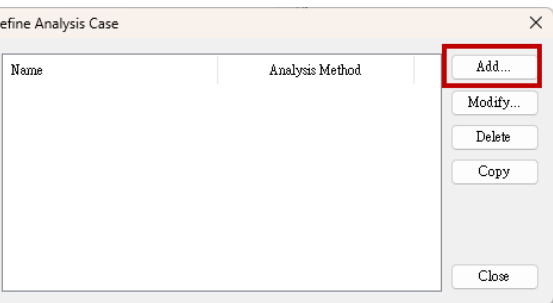

拖曳所有幾何集/邊界集

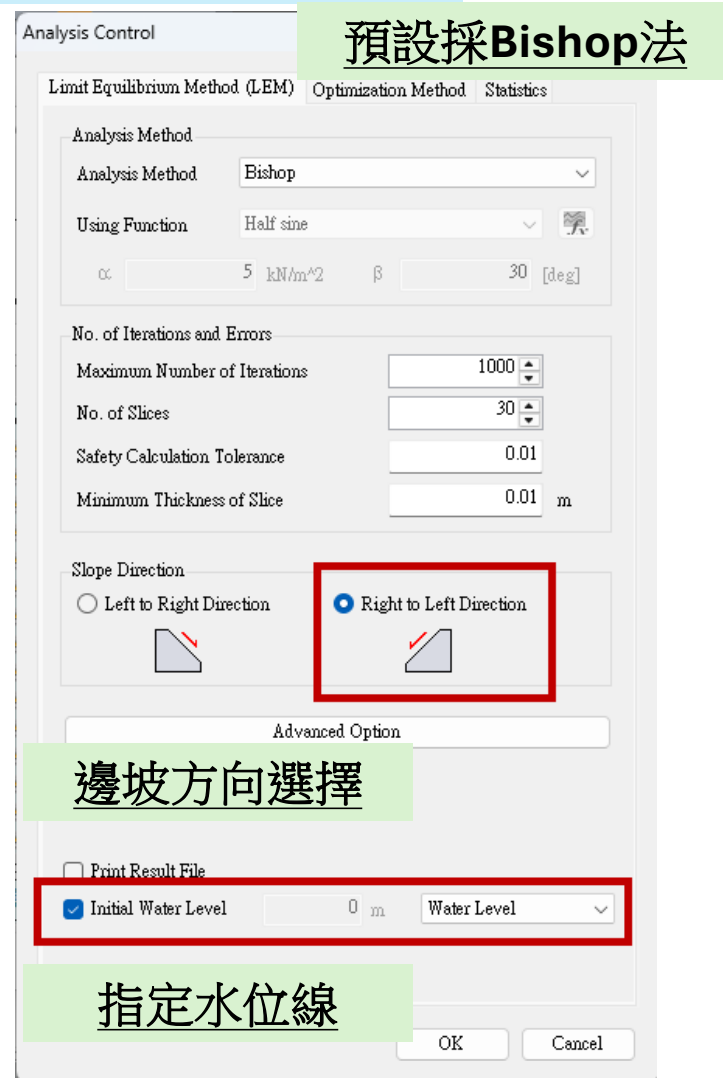

預設採Bishop法

邊坡方向選擇

指定水位線



計算

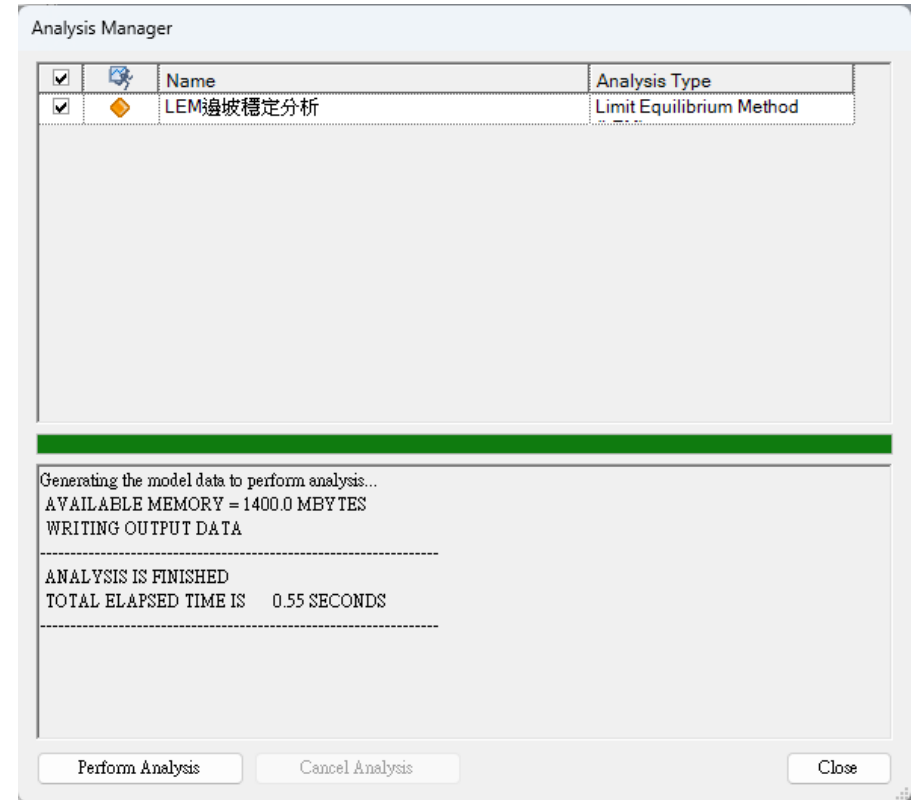
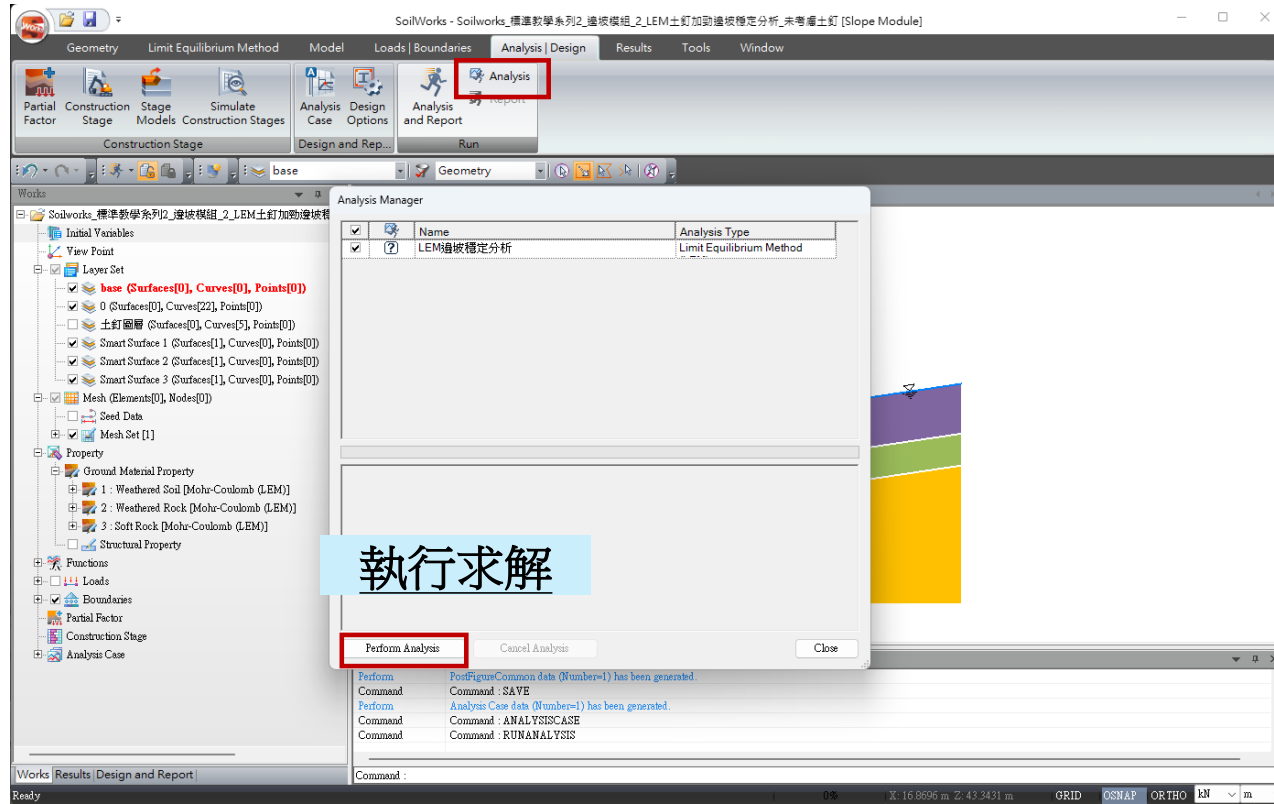

LEM分析結果

(未考慮土釘)

輸出結果

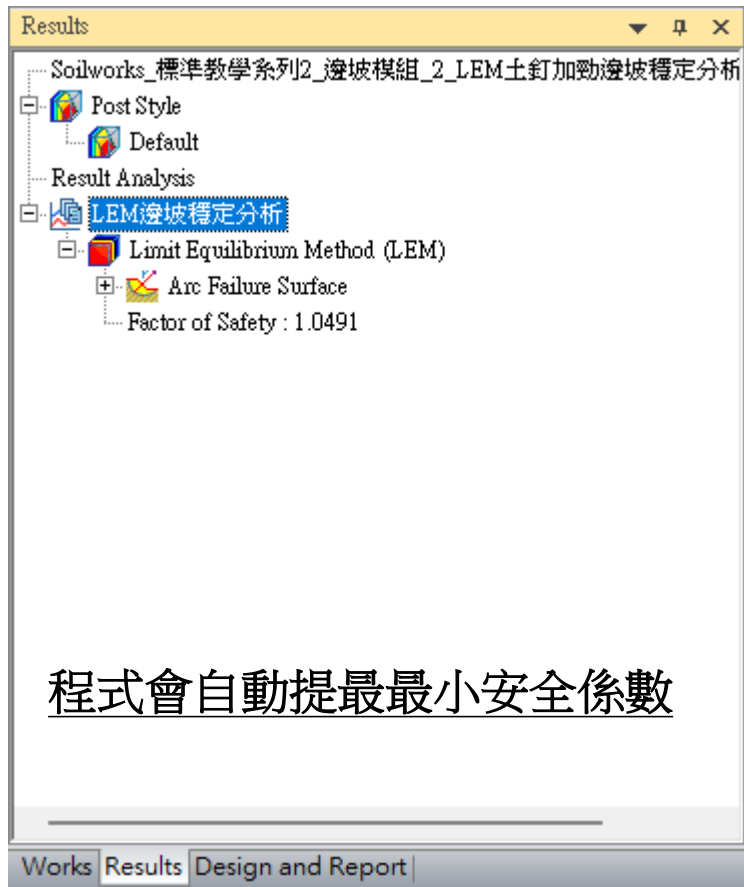

程式會自動提最最小安全係數

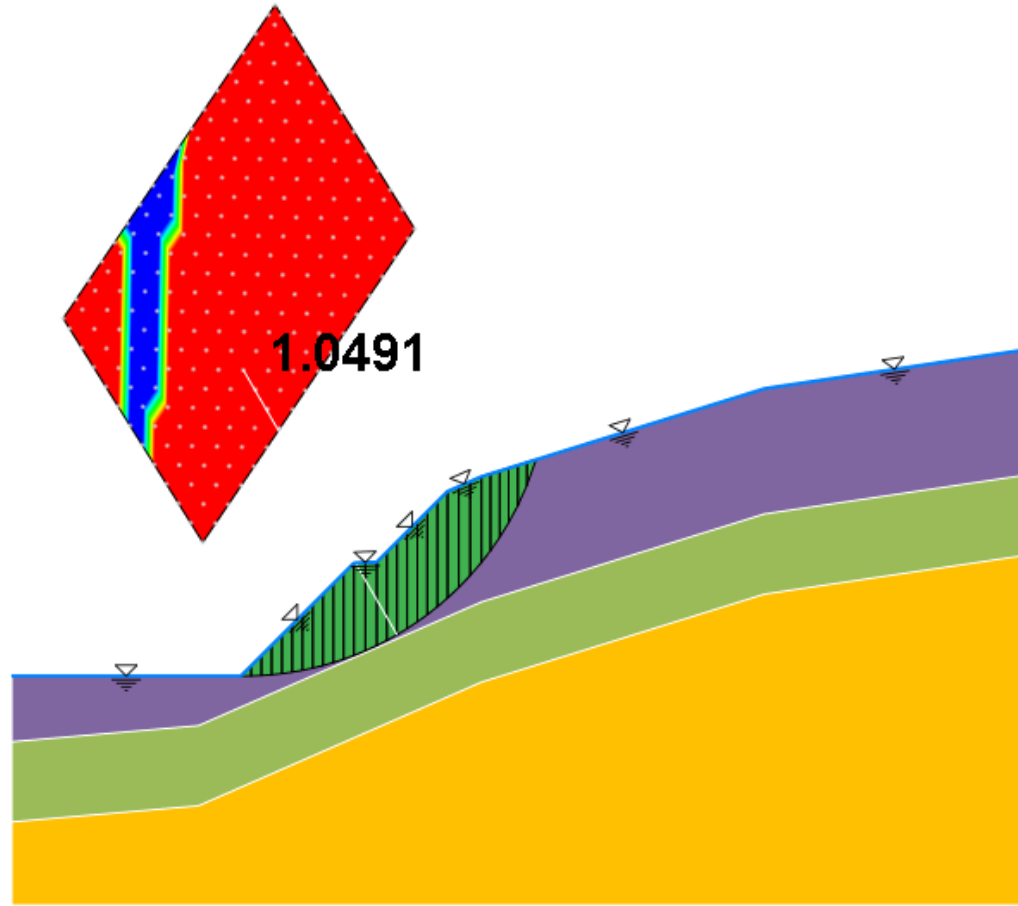

SoilWorks®

Safety Factor

Safety Factor	Percentage
+1.00000e+002	5.9%
+9.38156e+001	4.4%
+8.76311e+001	4.4%
+8.14467e+001	4.4%
+7.52623e+001	4.4%
+6.90778e+001	4.4%
+6.28934e+001	4.4%
+5.67090e+001	4.4%
+5.05245e+001	4.4%
+4.43401e+001	4.4%
+3.81557e+001	4.4%
+3.19712e+001	4.4%
+2.57868e+001	4.4%
+1.96024e+001	4.4%
+1.34179e+001	4.4%
+7.23351e+000	4.4%
+1.04907e+000	32.0%



檔案

LEM土釘加勁邊坡穩定分析_未考慮土釘



LEM結構材料屬性

Limit Equilibrium Method



完成LEM結構材料新增

Define Structural Property

ID	Name
1	Nail LEM

General

ID 1 Name Nail LEM

Element Type Nail (LEM)

Stiffness

General

Spacing	2 m
Initial Diffusion Width	1 m
Initial Diffusion Angle	10 [deg]
Adjust Reinf. Effect by FS	Independent

Reinforcement Load

Tensile Force	115 kN
Tension/Shear Application Method	Nail
<input checked="" type="checkbox"/> RCS calculation from qs	
Equivalent Radius	0.05 m
Pullout Force	kN/m
Shear Force	0 kN
Shear Force Function	None

Reset Add Modify Delete Close

自訂名稱:Nail LEM

材料切換成Nail(LEM)

依照下表參數輸入

Add新增材料

No	Structure Type	Model Type	Reinforcement Spacing (m)	Initial Diffusion Width (m)	Initial Diffusion Angle (deg)	Tensile Strength (kN)	Equivalent Radius (m)
1	Nail (LEM)	Nail (LEM)	2.0	1.0	10	115	0.05



結構材料屬性指定

顯示土釘層特徵

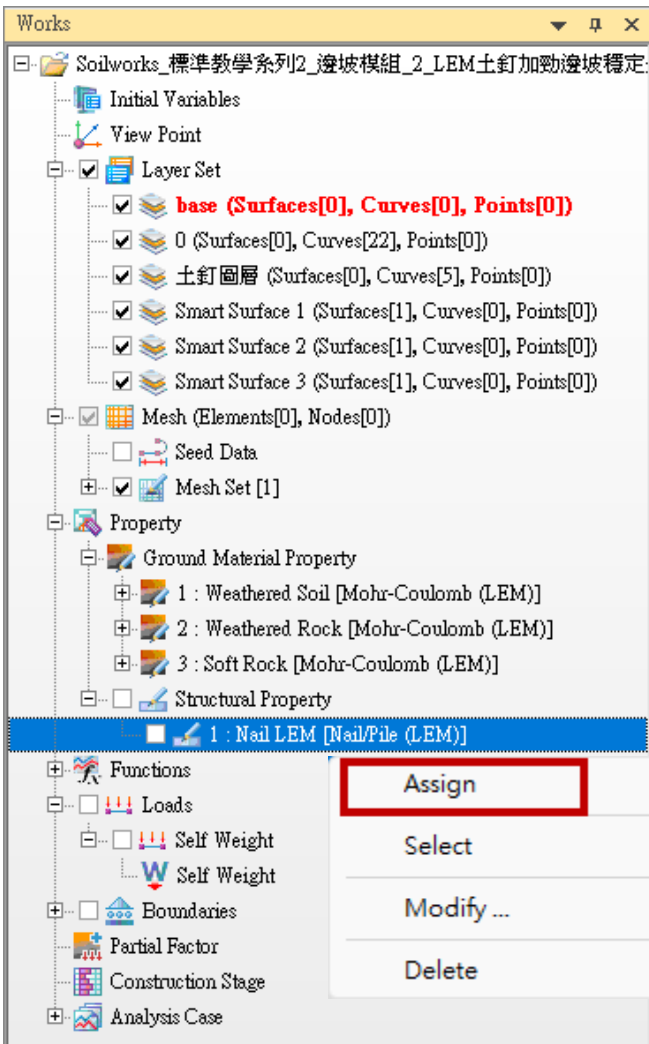

Select Filter 切換到 Curve

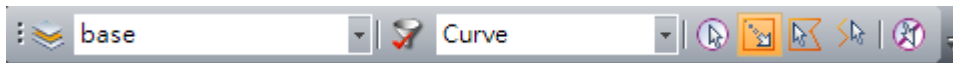

選取土釘特徵

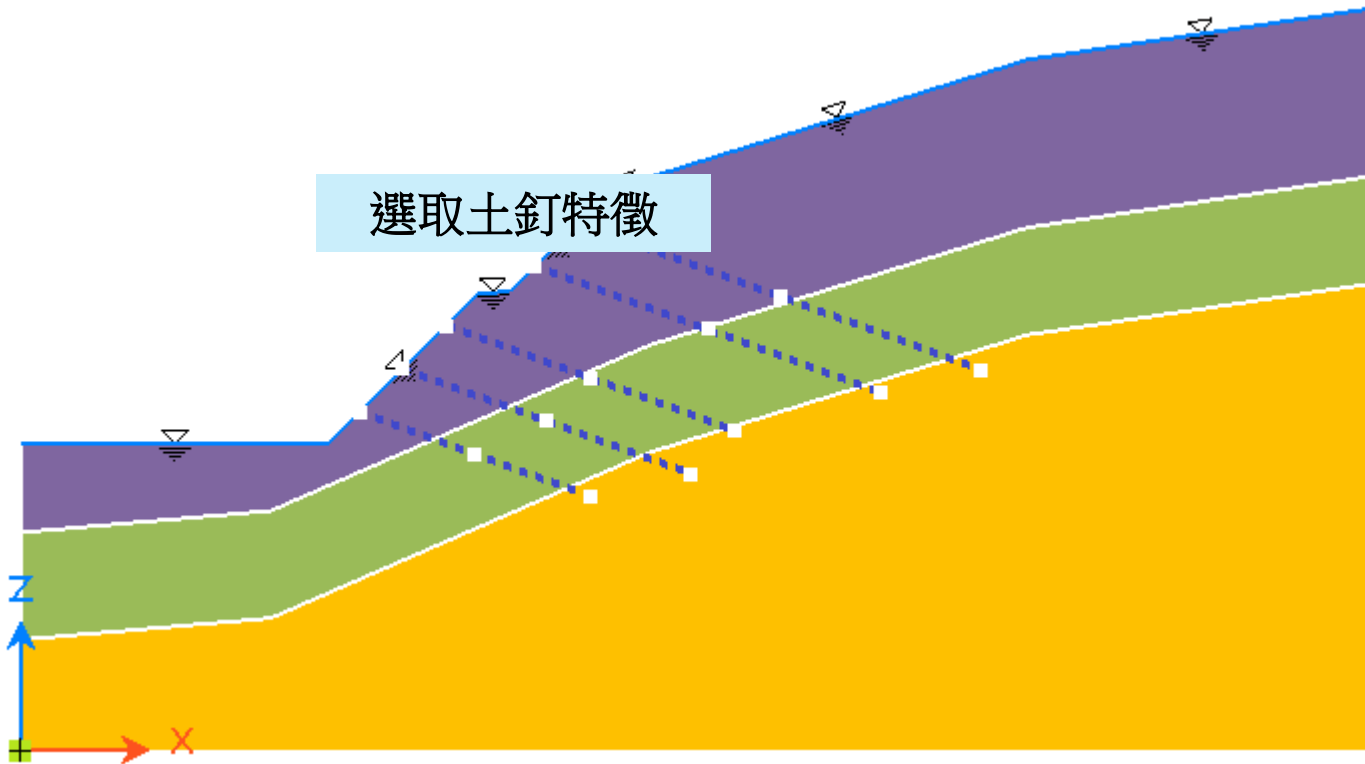

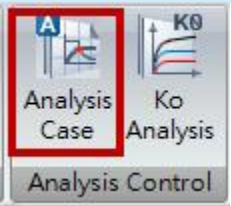

分析定義

(LEM土釘加勁邊坡穩定分析)

分析名稱: LEM土釘加勁邊坡穩定分析/分析類型: Limit Equilibrium Method(LEM)

預設採Bishop法

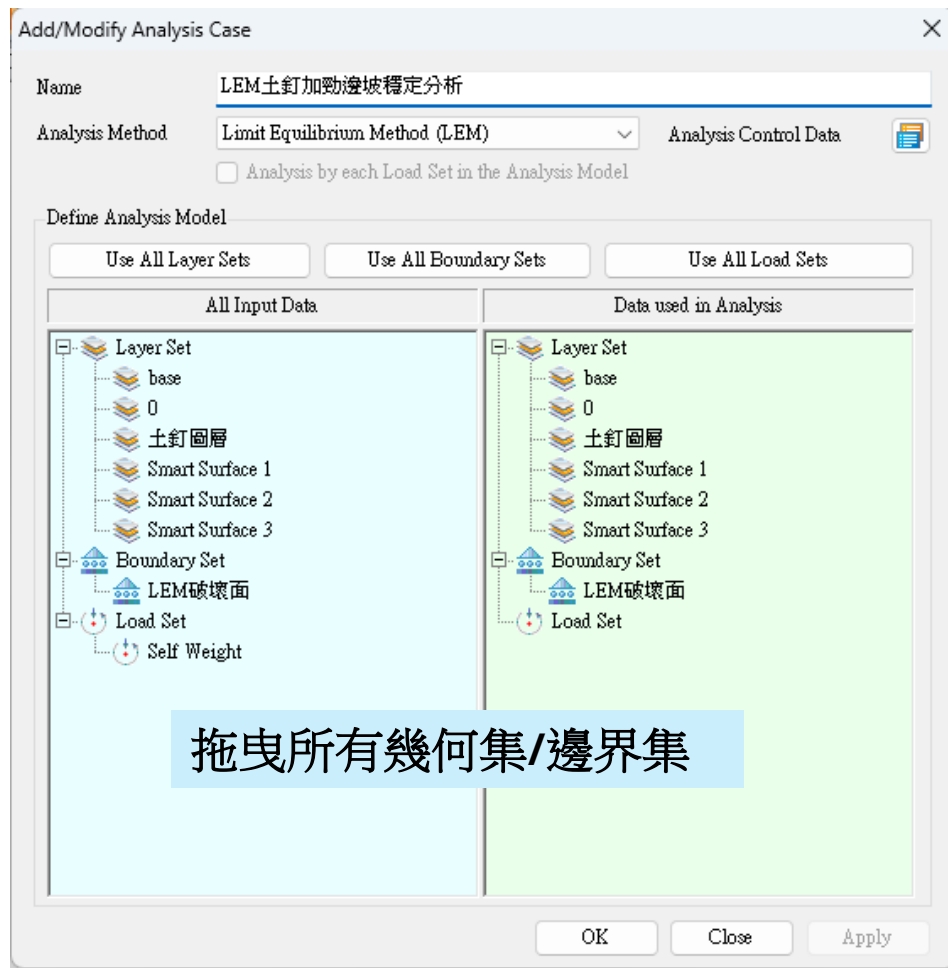
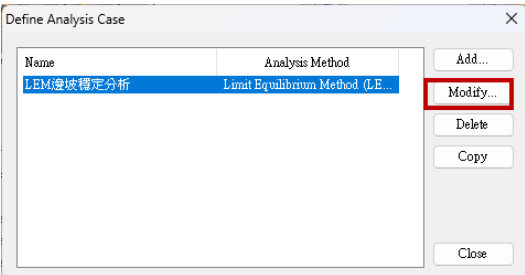

拖曳所有幾何集/邊界集



邊坡方向選擇

指定水位線



計算

SoilWorks - Soilworks_標準教學系列2_邊坡模組_2_LEM土釘加勁邊坡穩定分析_考慮土釘 (Slope Module)

Geometry | Limit Equilibrium Method | Model | Loads | Boundaries | Analysis | Design | Results | Tools | Window

Partial Factor | Construction Stage | Stage Models | Simulate Construction Stages | Analysis Case | Design Options | Analysis and Report | Report

base | Curve

Works

- Initial Variables
- View Point
- Layer Set
 - base (Surfaces[0], Curves[0], Points[0])
 - 0 (Surfaces[0], Curves[22], Points[0])
 - 土釘圍層 (Surfaces[0], Curves[5], Points[0])
 - Smart Surface 1 (Surfaces[1], Curves[0], Points[0])
 - Smart Surface 2 (Surfaces[1], Curves[0], Points[0])
 - Smart Surface 3 (Surfaces[1], Curves[0], Points[0])
- Mesh (Elements[0], Nodes[0])
 - Seed Data
 - Mesh Set [1]
- Property
 - Ground Material Property
 - 1 : Weathered Soil [Mohr-Coulomb (LEM)]
 - 2 : Weathered Rock [Mohr-Coulomb (LEM)]
 - 3 : Soft Rock [Mohr-Coulomb (LEM)]
 - Structural Property
 - 1 : Nail LEM [Nail/Plate (LEM)]
- Functions
- Loads
 - Self Weight
- Boundaries
- Partial Factor
- Construction Stage
- Analysis Case

Analysis Manager

<input checked="" type="checkbox"/>	Name	Analysis Type
<input checked="" type="checkbox"/>	LEM土釘加勁邊坡穩定分析	Limit Equilibrium Method

Perform Analysis | Cancel Analysis | Close

Message

```
Perform Structural Property data (Number=1) has been modified.
Perform Structural Property data (Name=Nail LEM) has been assigned to Curves (Number=5).
Perform Analysis Case data (Number=1) has been modified.
Command : ANALYSISCASE
Command : RUNANALYSIS
```

Works | Results | Design and Report | Ready

Command :

0% X: -8.8182 m, Z: 31.2289 m GRID OSNAP ORTHO kN m

Analysis Manager

<input checked="" type="checkbox"/>	Name	Analysis Type
<input checked="" type="checkbox"/>	LEM土釘加勁邊坡穩定分析	Limit Equilibrium Method

Generating the model data to perform analysis...
AVAILABLE MEMORY = 1400.0 MBYTES
WRITING OUTPUT DATA

ANALYSIS IS FINISHED
TOTAL ELAPSED TIME IS 0.56 SECONDS

Perform Analysis | Cancel Analysis | Close



LEM分析結果

(考慮土釘)

輸出結果

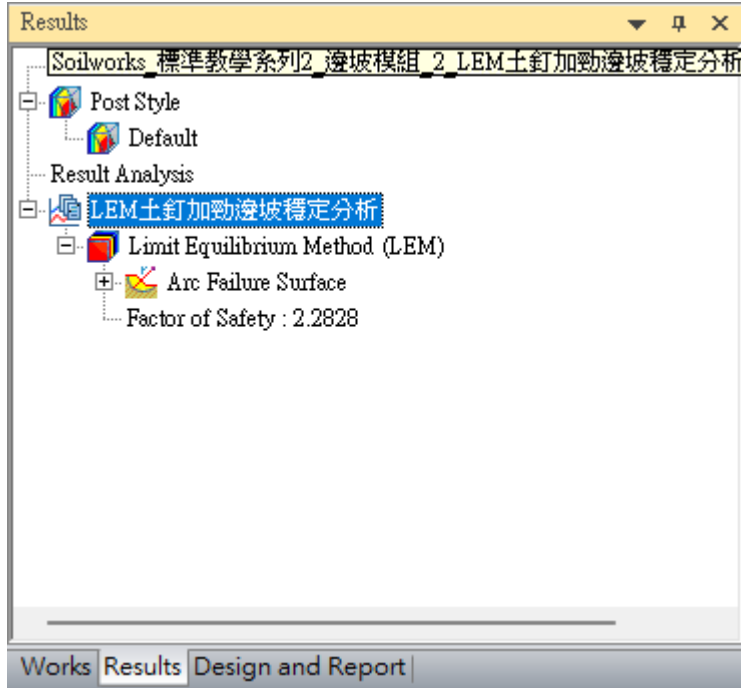

程式會自動提最最小安全係數

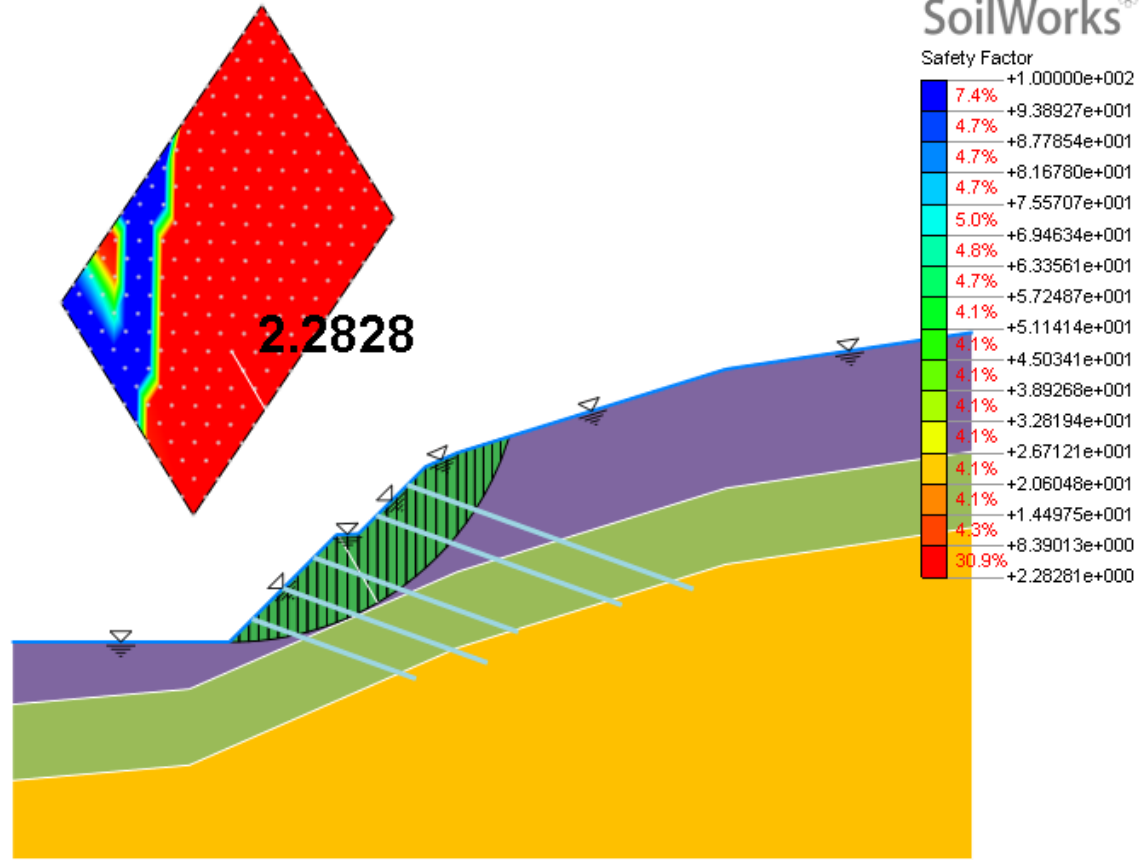

檔案

LEM土釘加勁邊坡穩定分析_考慮土釘



Part2.SRM土釘加勁邊坡穩定分析

(Strength Reduction Method (SRM)-強度折減法)



Strength Reduction Method (SRM)

(強度折減法)

有限元素法分析邊坡穩定性的方法有兩類：

- (1)直接法:強度折減法
- (2)間接法:應力分析法(結合極限平衡法進行安全係數計算)

強度折減法(SRM)

將邊坡地基材料的抗剪強度 (c, ϕ) 逐漸減小，直到計算中的發散點，此時假定發生了斜坡破壞，該點的最大強度折減率被認為是最小安全係數。

強度折減法需要迭代非線性分析，消耗大量分析時間，

- (1) 當土體的抗剪強度小於土體自重所引起的剪應力時，就會發生破壞，所以不需假設失效面。
- (2) 不需使用切片的概念直接進行計算，同時滿足平衡狀態直致失效。
- (3) 計算得到現地邊應力和變形。

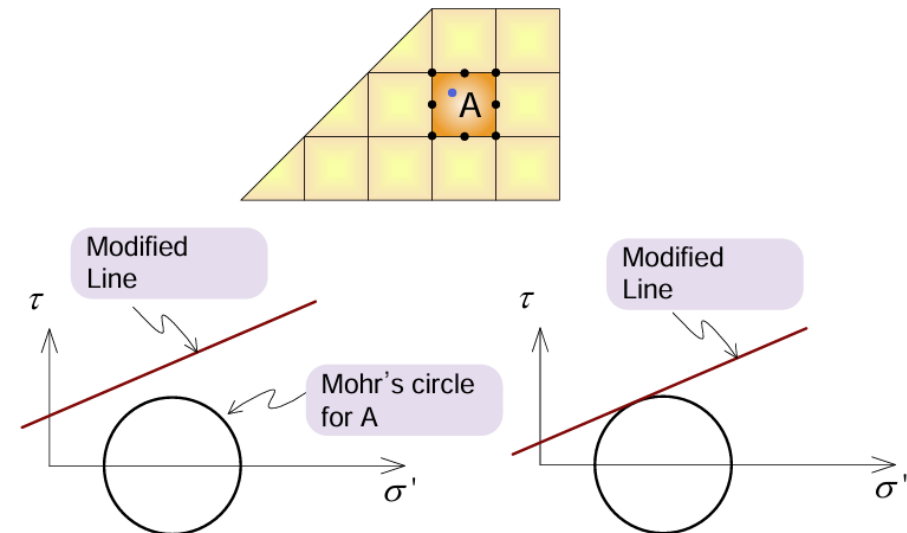

Reference

GTS NX/FEA NX/Soilworks Manual



邊坡(Slope)模組



選擇邊坡(Slope)模組



單位切換

The screenshot displays the MIDAS Gen software interface. The main window shows a project tree on the left and a central workspace. Two dialog boxes are open:

- Define Initial Parameters:** A dialog box with a light blue header "使用者自訂使用單位". It shows the "Unit System" set to "User Defined...". The "Initial Parameters" section includes:
 - Gravitational Acceleration: 9.807 m/sec²
 - Unit Weight of Water: 9.807 kN/m³
 - Initial Temperature: 0.000 [T]
- Unit settings:** A dialog box with a light blue header "單位使用KN/m/sec". It shows the following settings:
 - Force Unit [F]: kN (selected)
 - Length Unit [L]: m (selected)
 - Time Unit [T]: sec (selected)

A 3D coordinate system with X, Y, and Z axes is visible in the workspace.



DWG模型匯入

Import>CAD File



匯入後線特徵模型

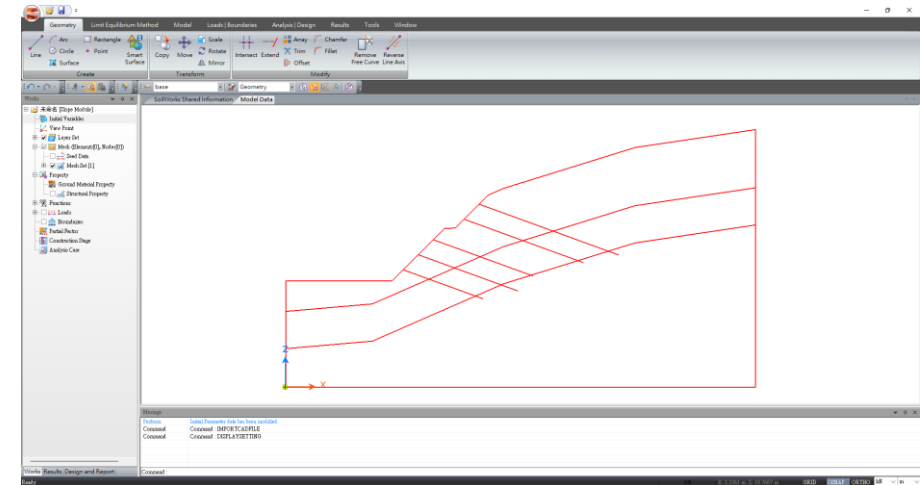

新增土釘圖層

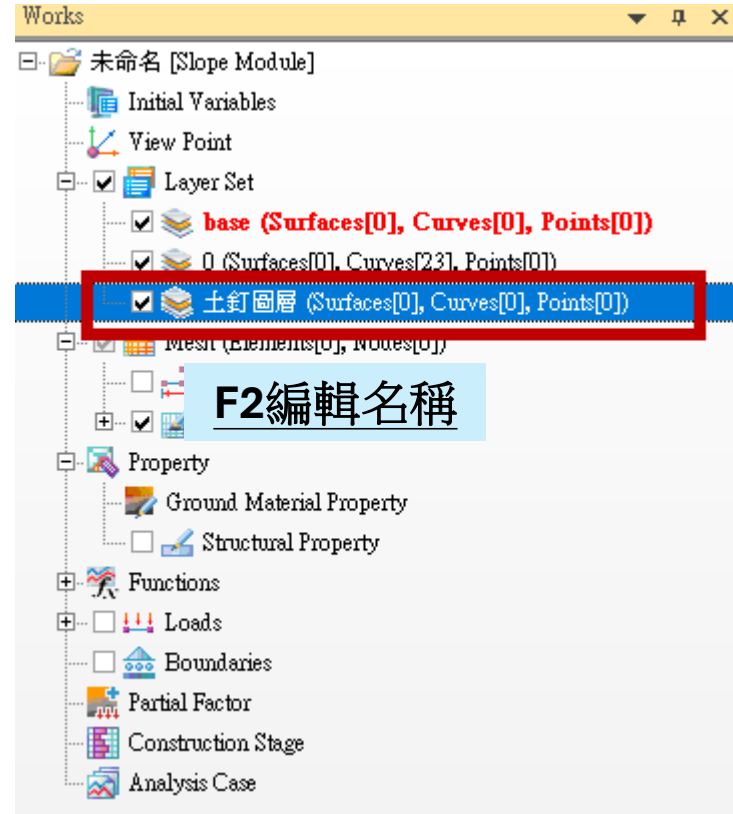
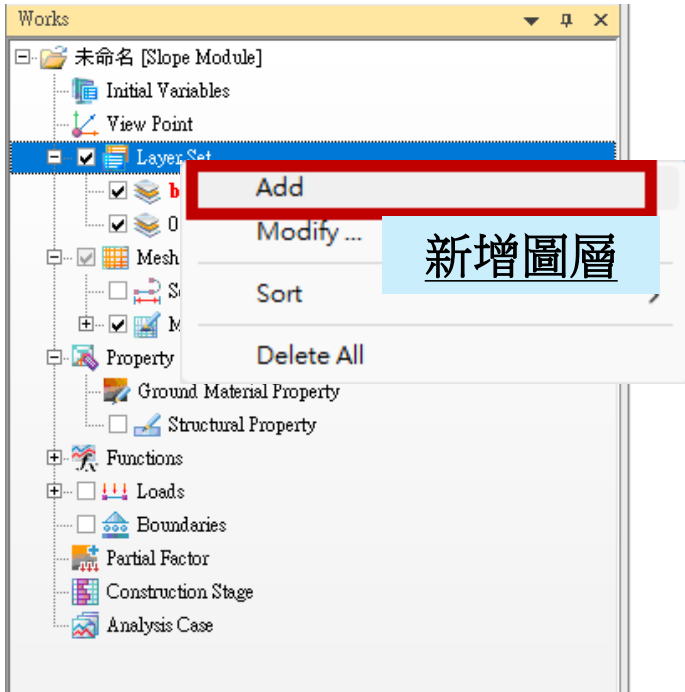

土釘圖層編輯

Select Filter 切換到 Curve

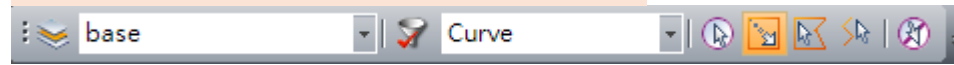

移動土釘特徵到土釘圖層

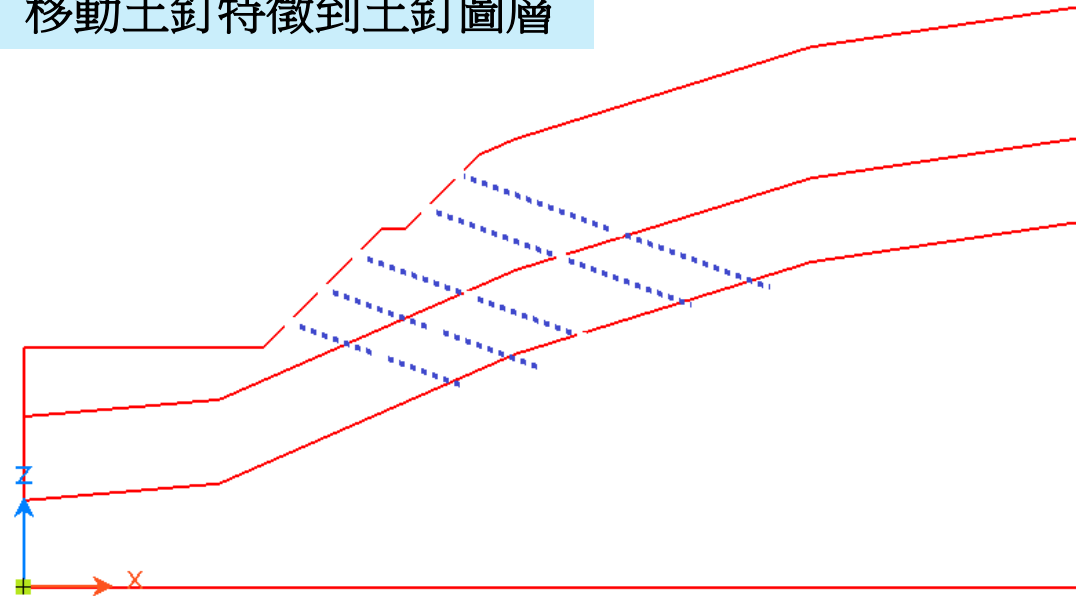
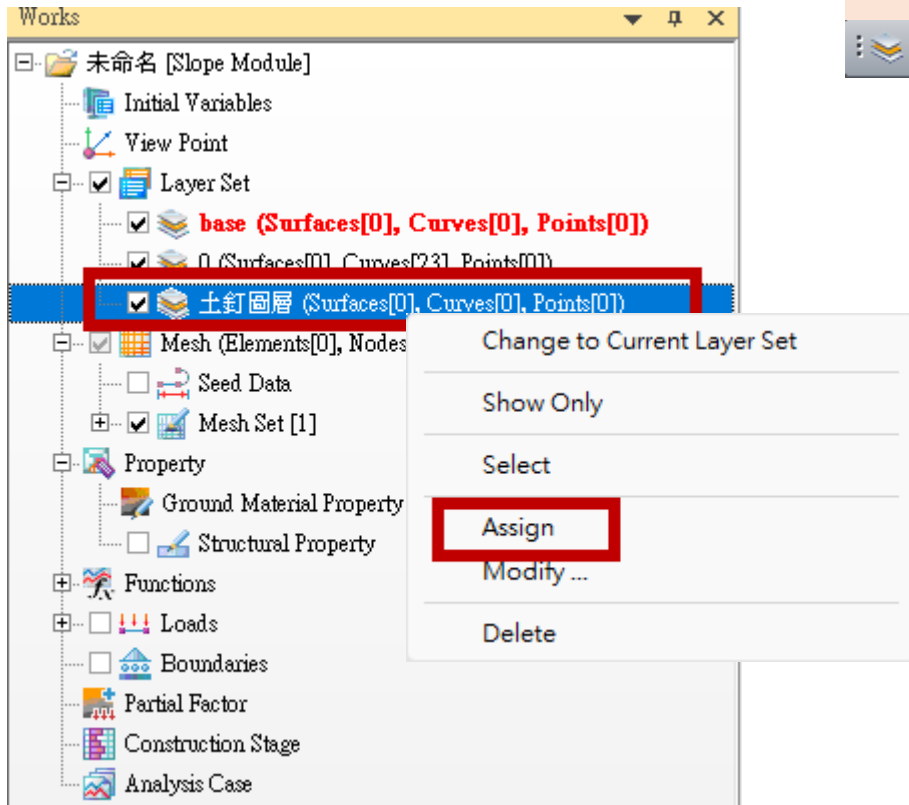

Geometry 選單>Smart Surface

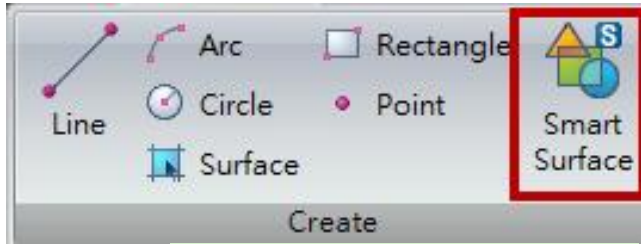

自動生成面特徵

隱藏土釘圖層

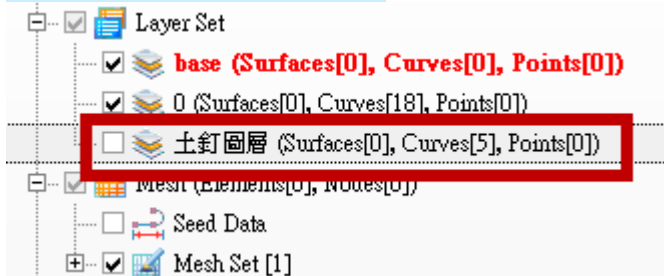

面特徵建立

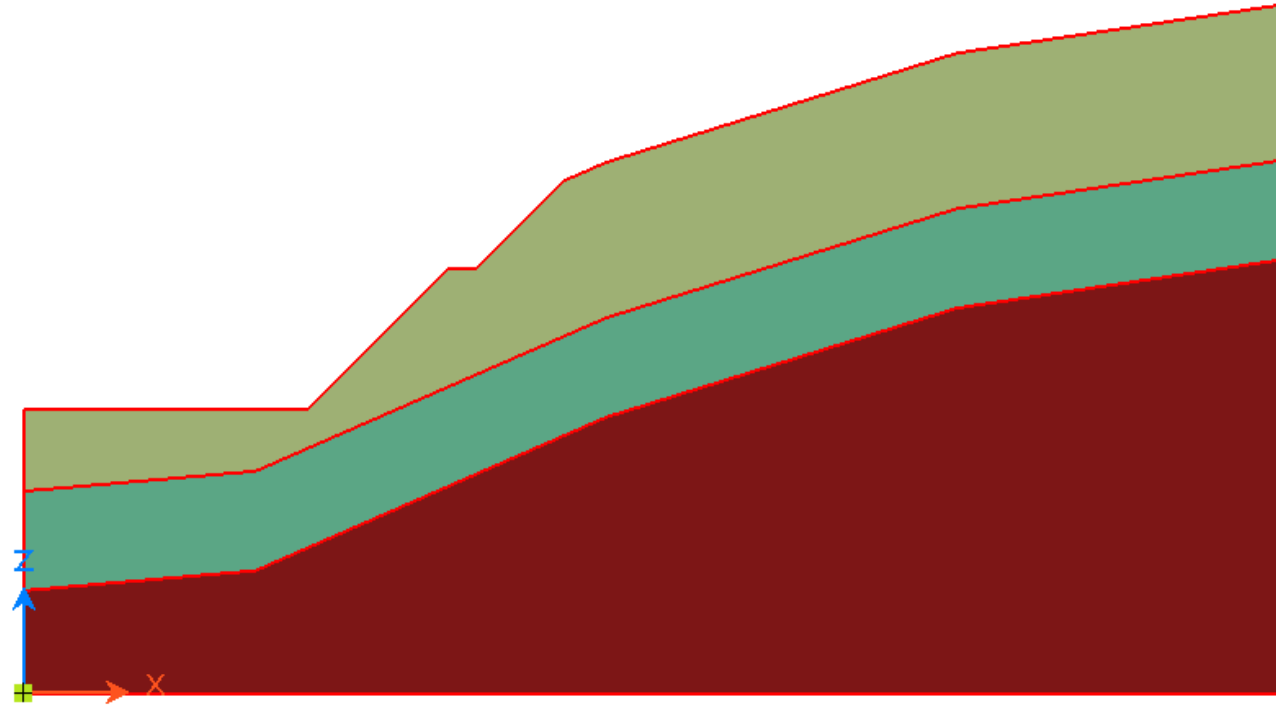

Layer Color(顏色顯示方式)

土壤材料屬性(Soilworks材料庫)

Model

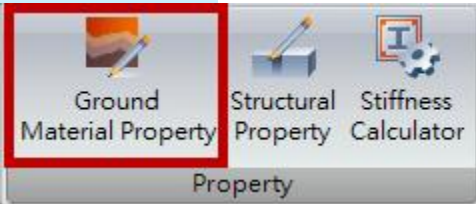

選取 1.1schist#1 類別

Ground Material Database

Database: 1.1 Schist#1

No.	Soil Type	Modulus of Elasticity (kN/m ²)	Unit Weight (kN/m ³)	Saturated Unit Weight (kN/m ³)	Poisson's Ratio	Cohesion (kN/m ²)	Internal Friction Angle	Select
1	Landfill Layer	13000	18	19	0.33	0	27	<input type="checkbox"/>
2	Alluvial Layer	8000	17	18	0.35	15	20	<input type="checkbox"/>
3	Weathered Soil	36500	18.5	19.5	0.33	17.5	31	<input checked="" type="checkbox"/>
4	Weathered Ro	150000	21	22	0.3	50	33	<input checked="" type="checkbox"/>
5	Soft Rock	1850000	24	25	0.28	180	35.5	<input checked="" type="checkbox"/>
6	Hard Rock	17500000	26	27	0.23	1750	40.5	<input type="checkbox"/>

選取 No3~No5

Assign新增材料

Reset Save Model Type: Mohr-Coulomb Assign Close

Define Ground Material Property

Data: ID 1 Name

General: ID 1 Name Model Type Mohr-Coulomb

General Parameters:

Modulus of Elasticity (E)	20000000	kN/m ²
Poisson's Ratio (u)	0.3	
Temperature Coeff. (a)	1E-06	
Unit Weight (Yt)	20	kN/m ³
Saturated Unit Weight	21	kN/m ³
Cohesion (c)	30	kN/m ²
Internal Friction Angle (Φ)	36	[deg]
Earth Pressure Coeff. (Ko)	1	
Draining Condition	Drained	

Additional Parameters:

Variation in Modulus of Elasticity	0	kN/m ²
Variation in Cohesion	0	kN/m ²
Reference Height	0	m
<input type="checkbox"/> Dilatancy Angle (ψ)	36	[deg]
<input type="checkbox"/> Tensile Strength	2000	kN/m ²

Database ... Material Statistic Add Modify Delete Close

Soilworks材料庫

完成Mohr-Coulomb土壤材料新增



顏色顯示(補充)

自訂屬性顏色

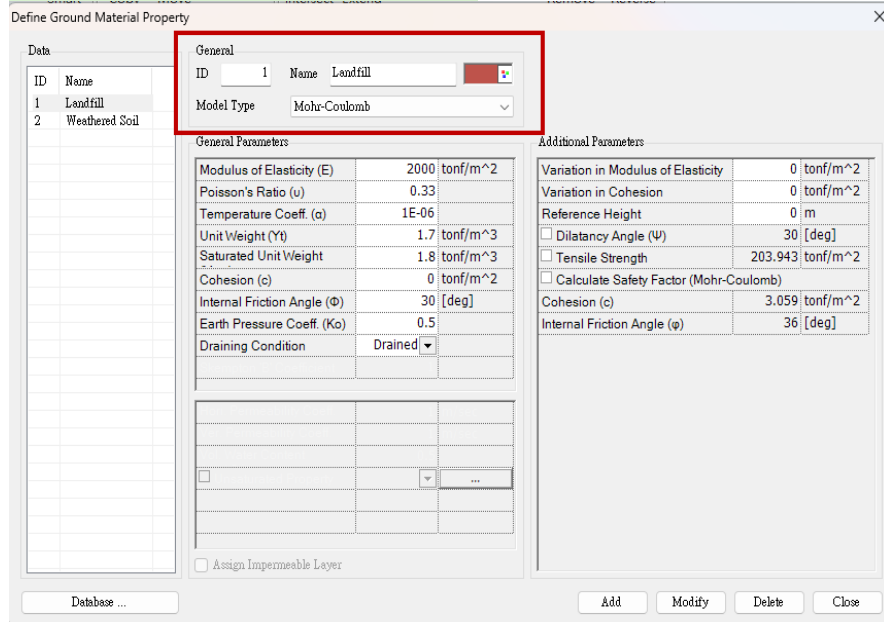

Display Setting顯示設定

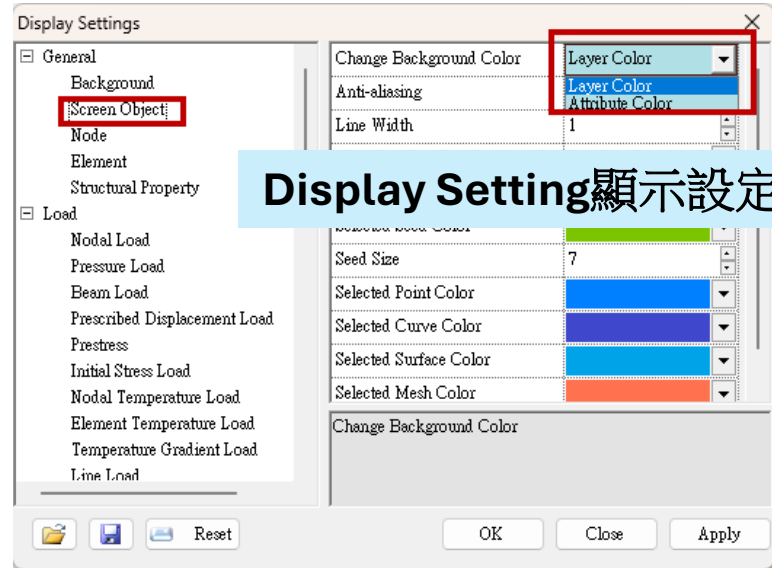

Display Setting顯示設定

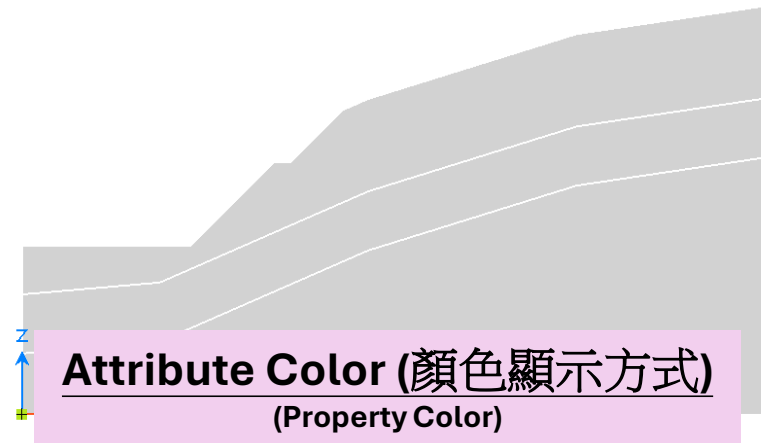

土壤材料屬性指定

Select Filter 切換到 Surface

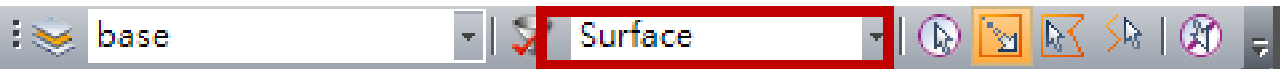

框選 Weathered Soil 分布區域特徵

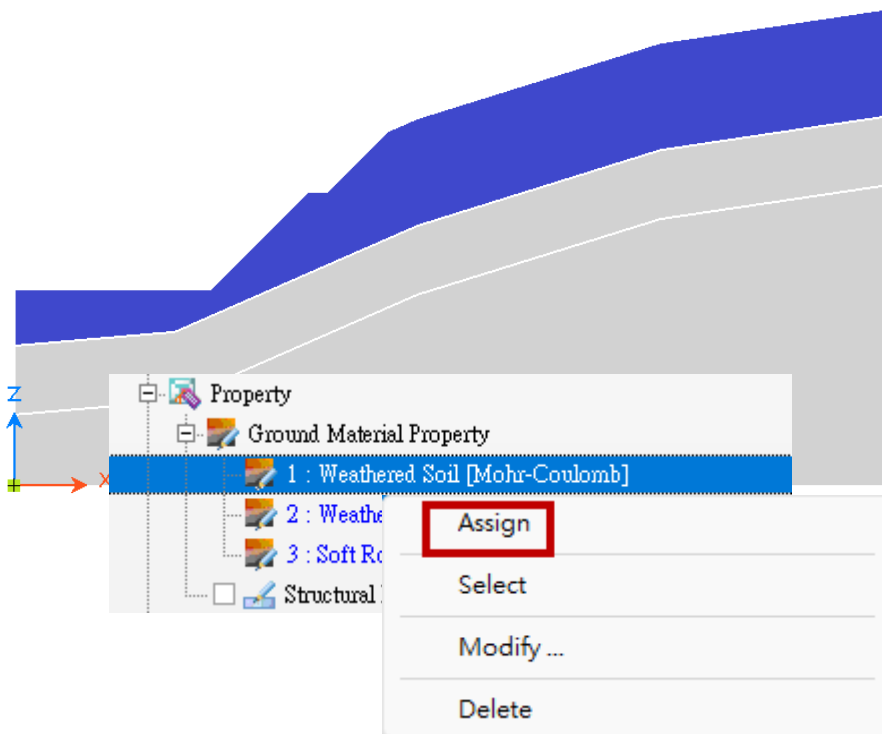

框選 Weathered Rock 分布區域特徵

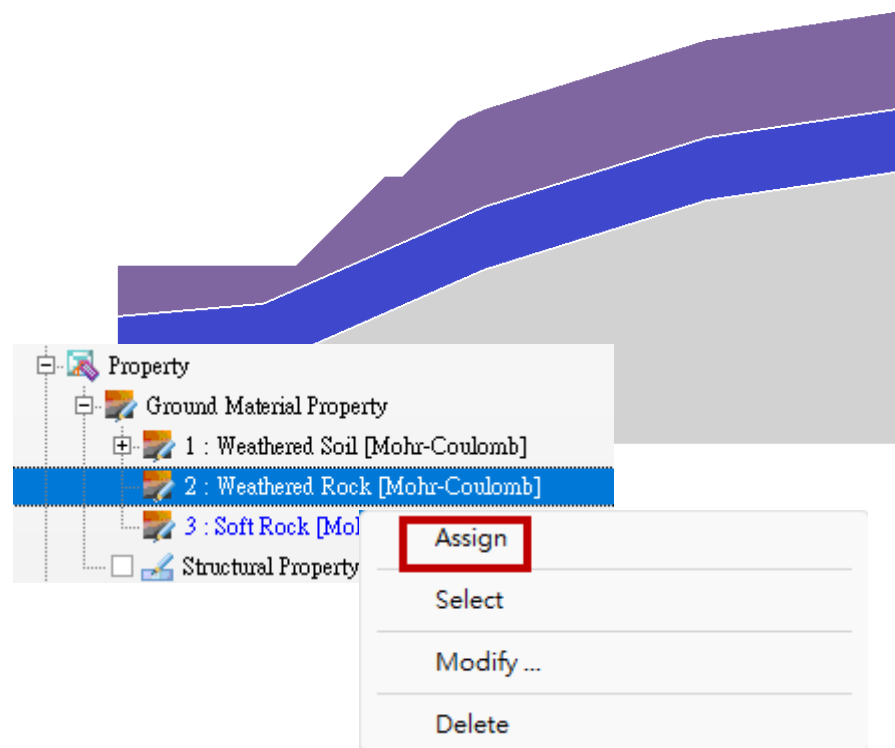

土壤材料屬性指定

Select Filter 切換到 Surface

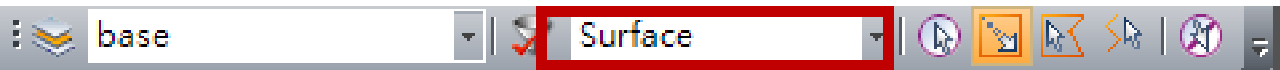

框選 Soft Rock 分布區域特徵

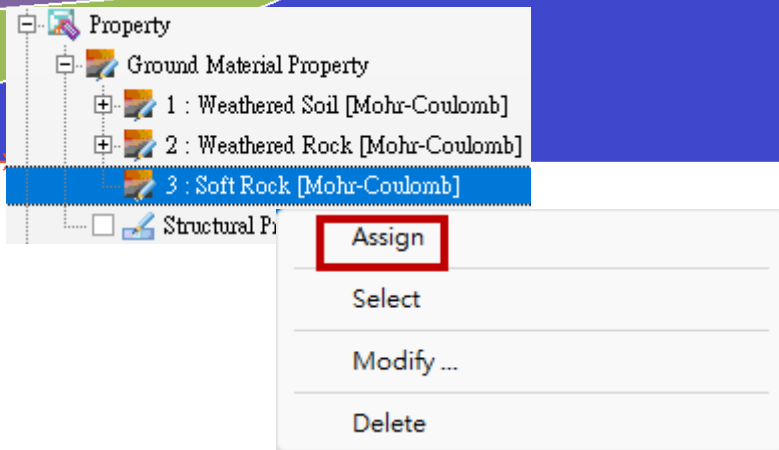
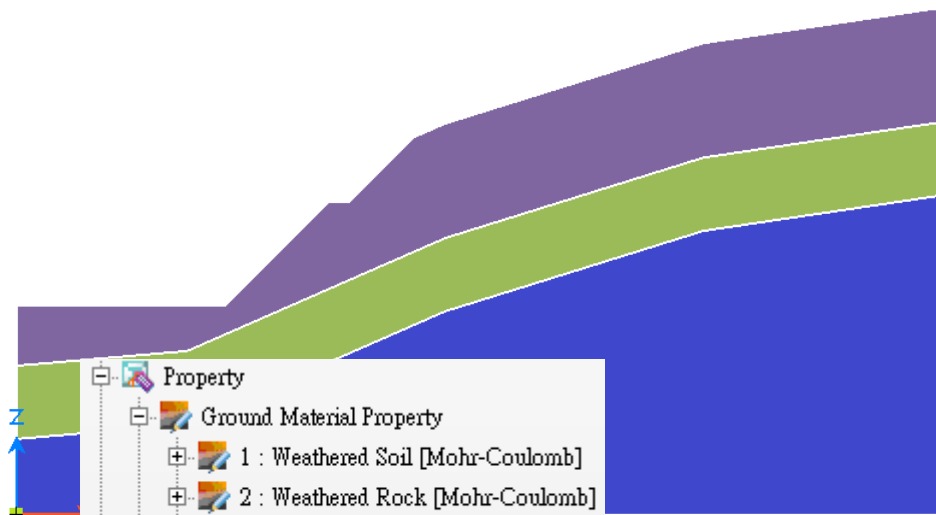

Ground Material Property 模型樹顯示指定特徵數量

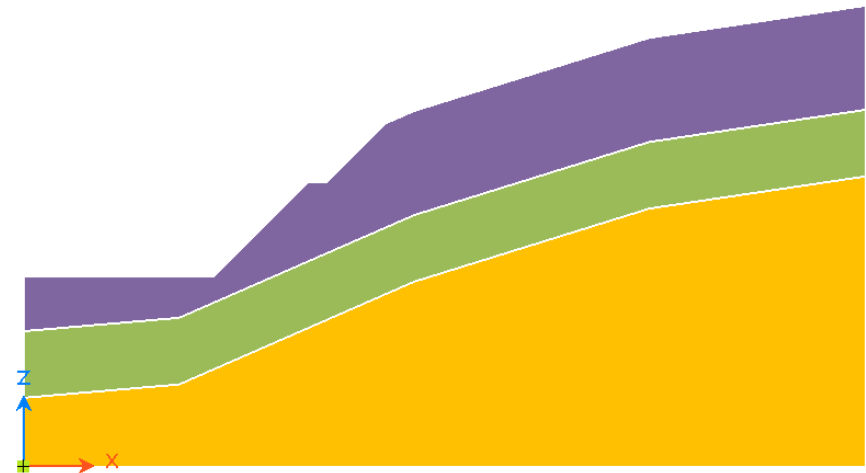
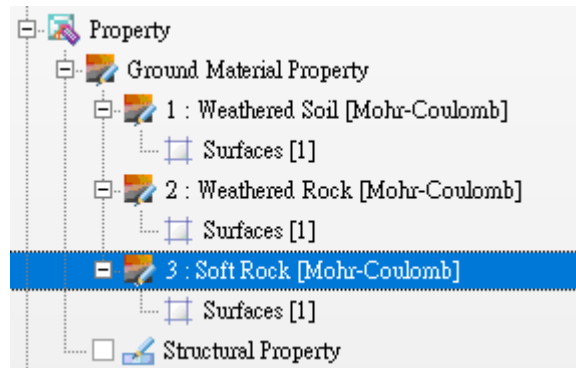

Model選單> Mesh

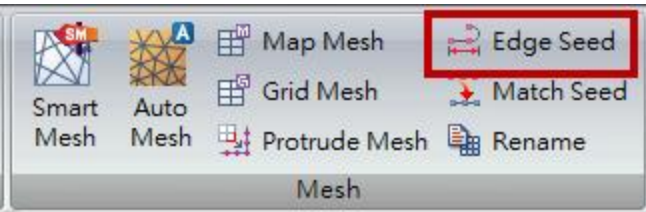

指定網格尺寸

Select Filter 切換到 Curve

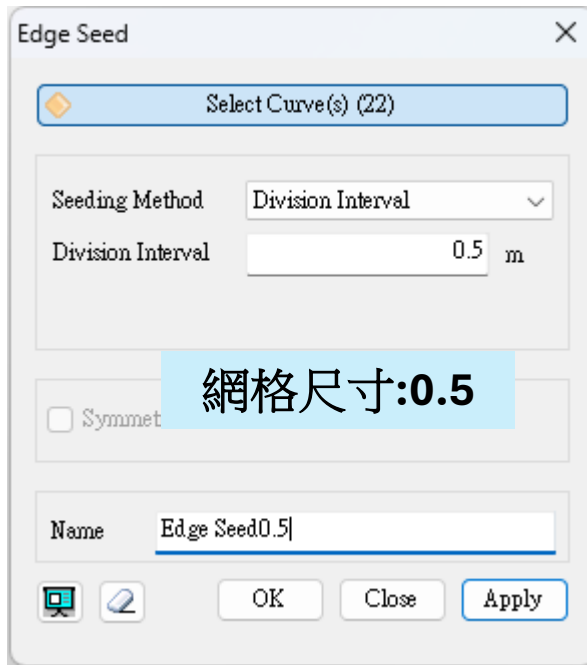
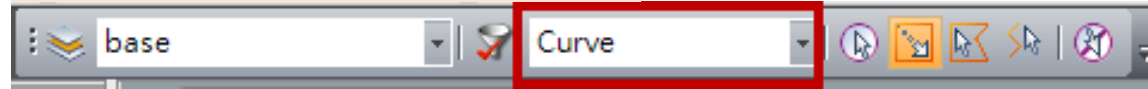

框選所有線特徵

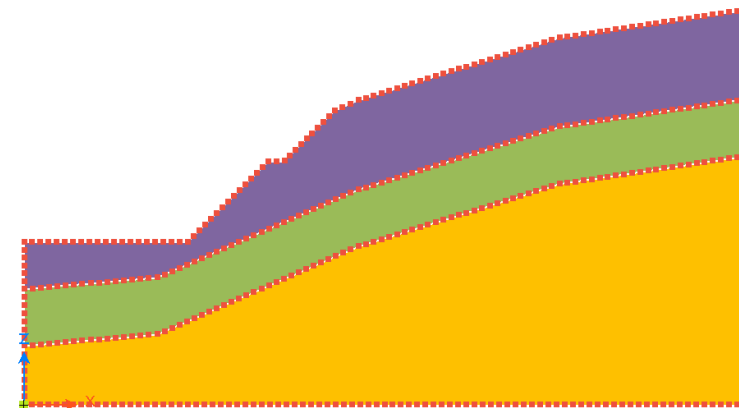
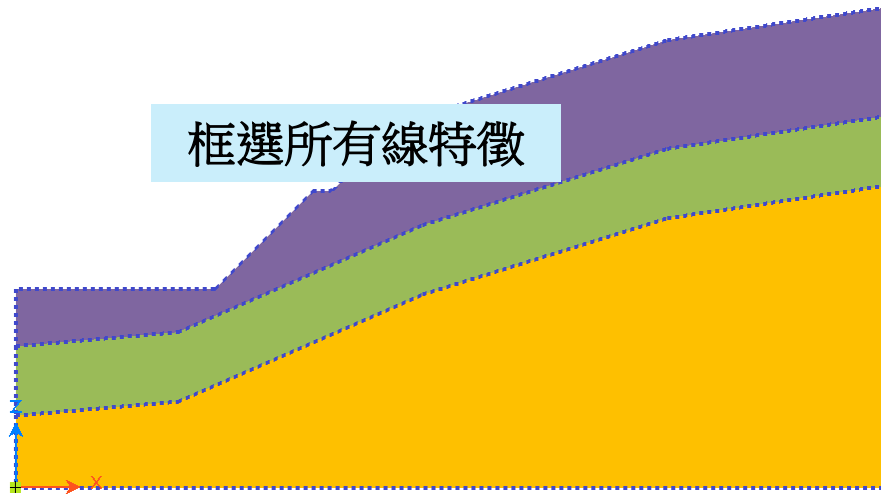

Model選單> Mesh

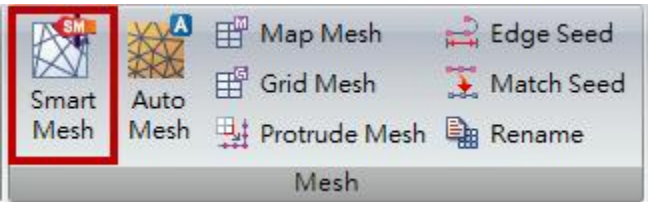

2D網格生成

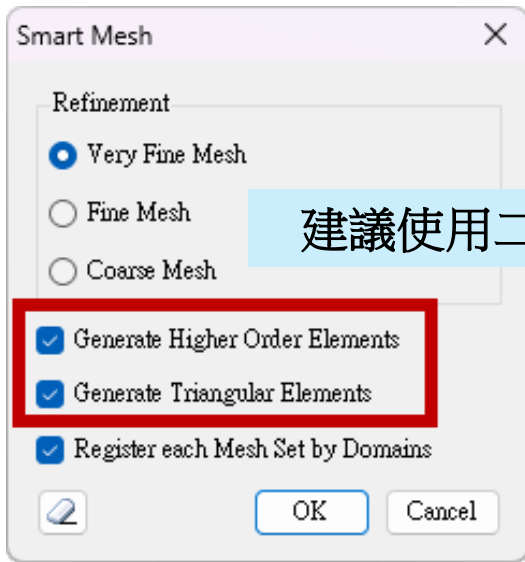

建議使用二階&三角形元素

每個面特徵各別生成網格集

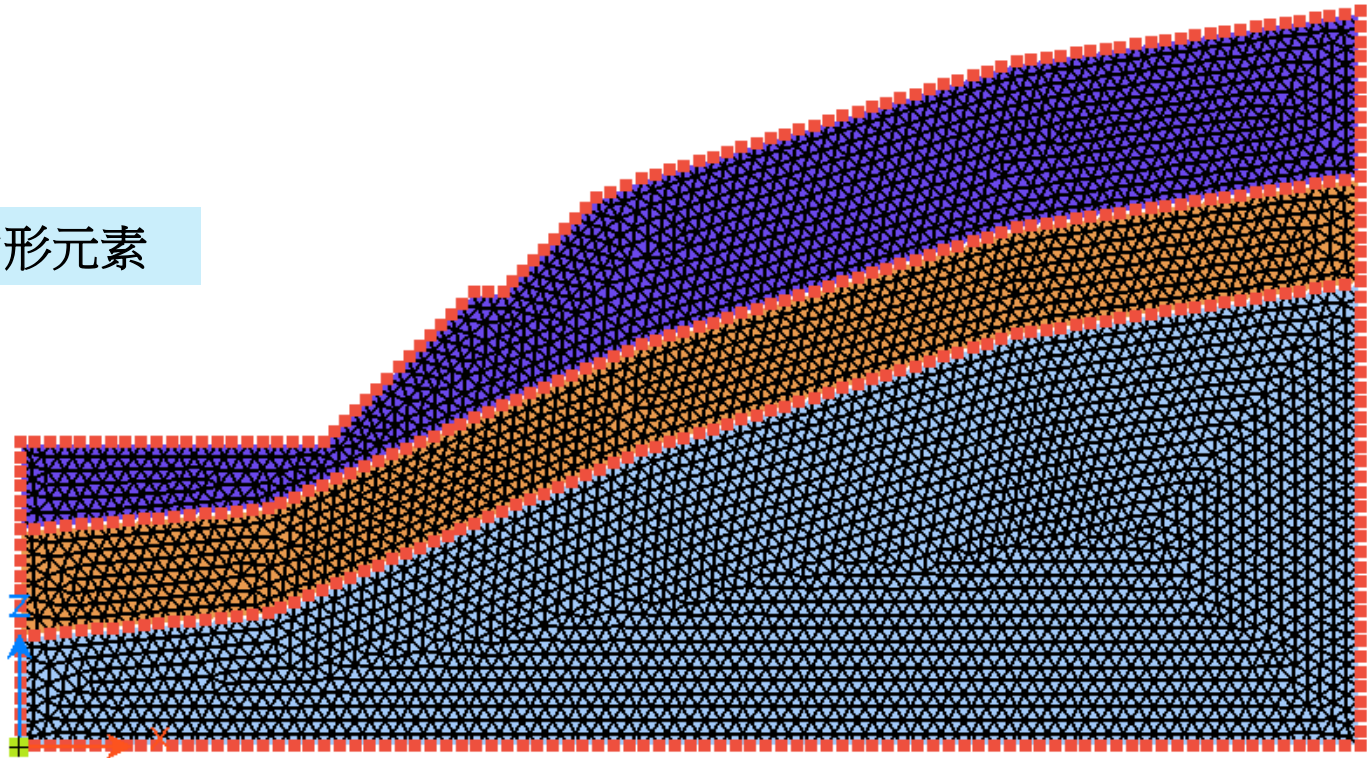

水位線

Loads | Boundaries



Water Level

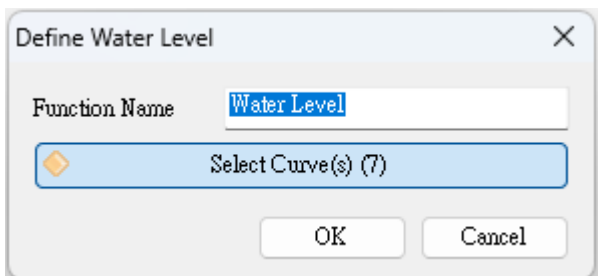

Select Filter 切換到 Curve

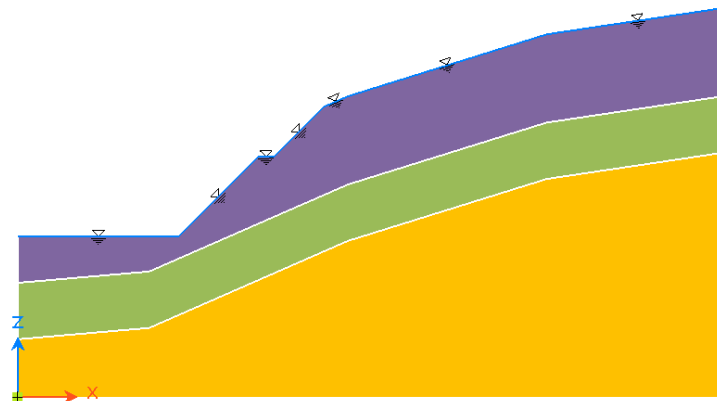
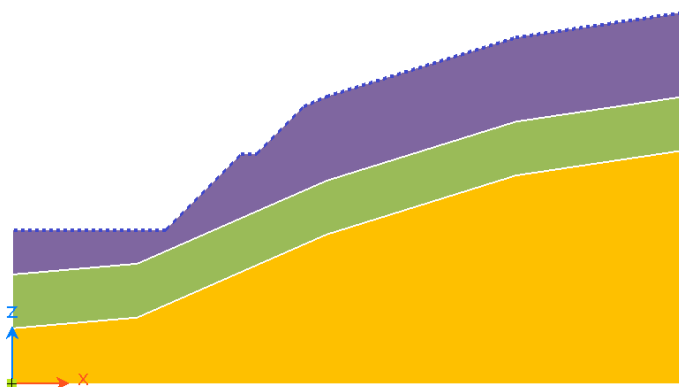
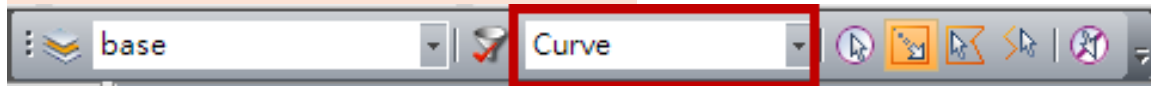

拘束條件

(自動判斷)

Loads | Boundaries 選單

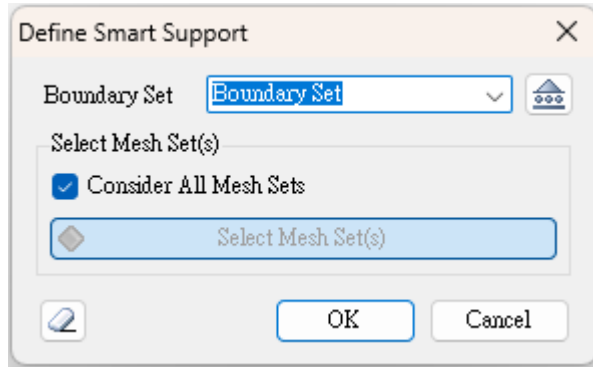

自動施加拘束條件

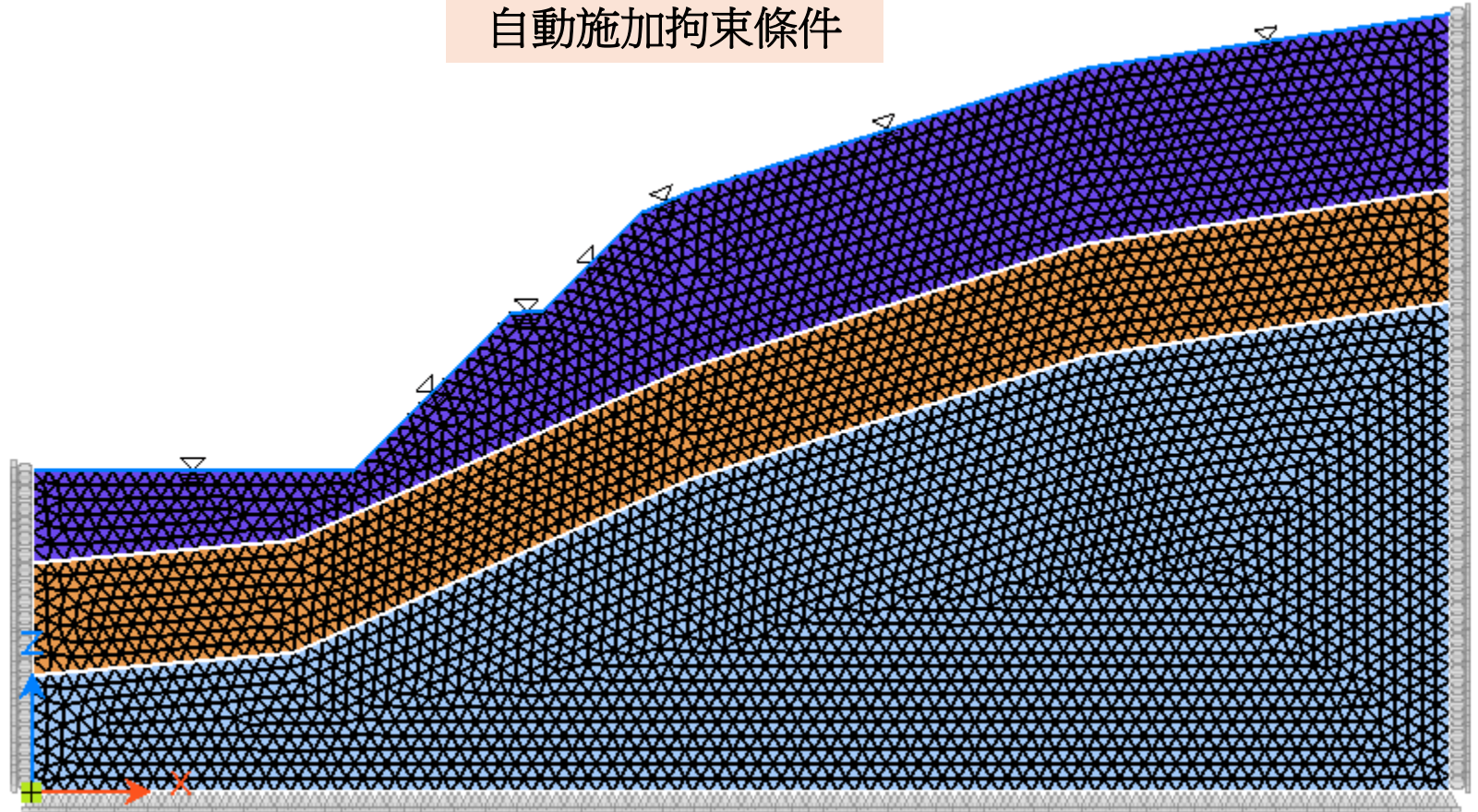

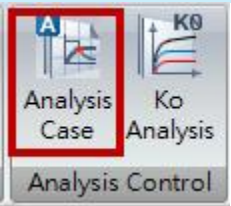

分析定義 (SRM邊坡穩定性分析)

分析名稱:SRM邊坡穩定性分析/分析類型: Strength Reduction Method (SRM)

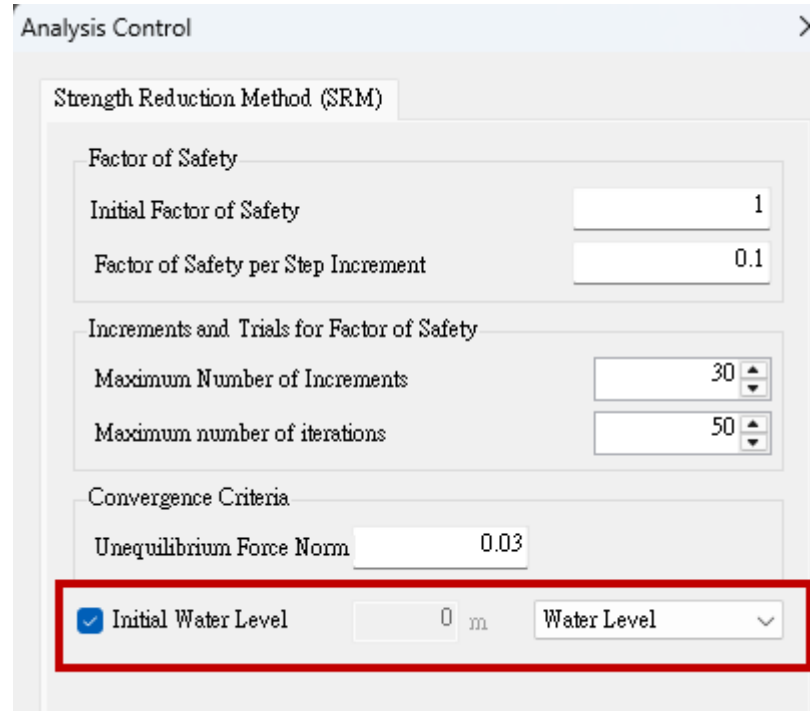
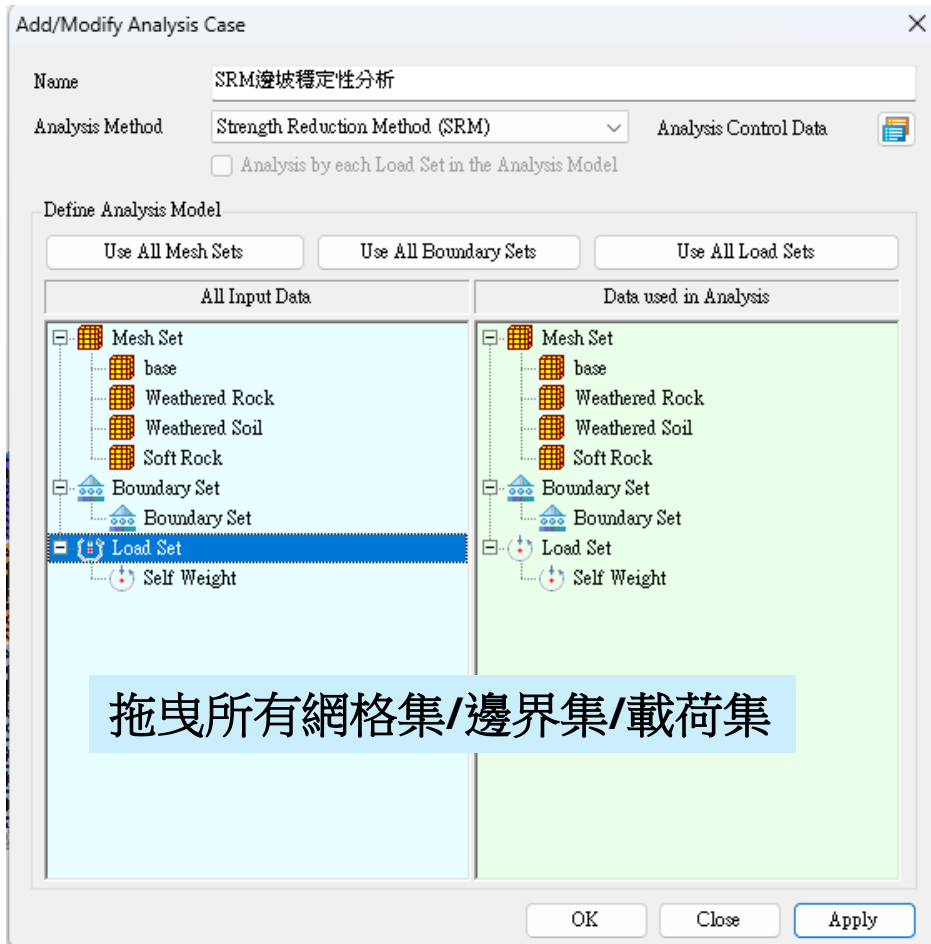
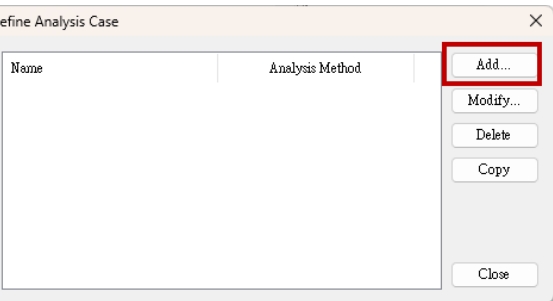

計算

SoilWorks - Soilworks_標準教學系列2_邊坡模組_2_SRM土釘加勁邊坡穩定分析_未考慮土釘 [Slope Module]

Geometry | Limit Equilibrium Method | Model | Loads | Boundaries | Analysis | Design | Results | Tools | Window

Partial Factor | Construction Stage | Stage Models | Simulate Construction Stages | Analysis Case | Design Options | Analysis and Report | Report

Construction Stage | Design and Rep... | Run

執行求解

Works | base | Surface

SoilWorks Shared Information | Model Data

Analysis Manager

<input checked="" type="checkbox"/>	<input checked="" type="checkbox"/>	Name	Analysis Type
<input checked="" type="checkbox"/>	<input checked="" type="checkbox"/>	SRM邊坡穩定性分析	Strength Reduction Method

Perform Analysis | Cancel Analysis | Close

計算迭代過程

Message

```
Perform Analysis Case data (Number=1) has been generated.
Command : ANALYSISCASE
Perform Analysis PostFigureCommon data (Number=1) has been generated.
Command : SAVEAS
Command : RUNANALYSIS
```

Works | Results | Design and Report

Ready | X: 4.4832 m Z: 28.0166 m | GRID | OSNAP | ORTHO | kN | m



SRM分析結果

輸出結果



SRM透過水平變形和最大剪切應變判斷破壞面

Tx Translation(m)

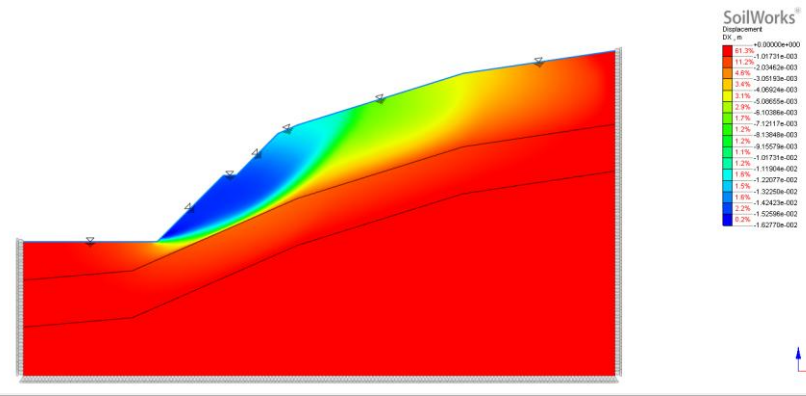

Maximum Shear Strain

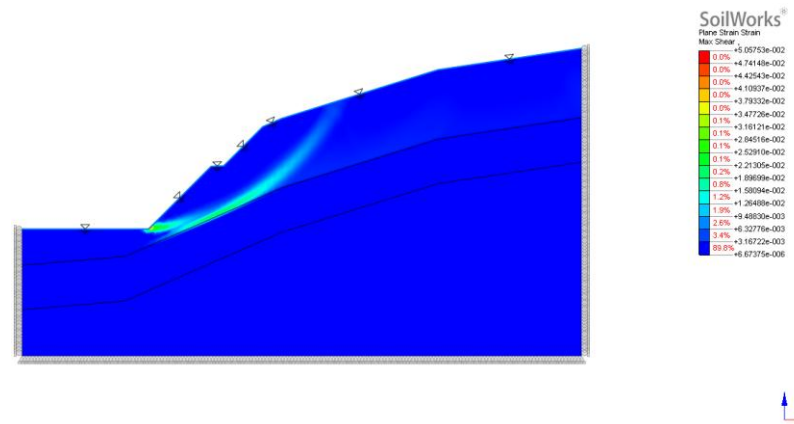

程式會自動輸出安全係數

檔案

SRM土釘加勁邊坡穩定分析_未考慮土釘



結構屬性-Nail

Model選單>Property



General

ID 1 Name Nail

Element Type Embedded Truss

Standard NONE

Horizontal Spacing 2 m

Section

Shape Round Tapered Section

Sub-Shapes U Type

Section User Defined

Section-2 User Defined

Material

Material Type Steel

Concrete User Defined

SteelGrade User Defined

自訂名稱:Nail

Section Data Material Data

Section Section-2 Stiffness

Section

D 0.0288 m

Stiffness Calculation

Area 0.000651 m²

依照下表參數輸入

Section Data Material Data

User Defined Steel

Properties

Modulus of Elasticity	210000000 kN/m ²
Poisson's Ratio	0.3
Unit Weight	80 kN/m ³
Thermal Coefficient	0.000012
Design Strength	
Yield Strength	400000 kN/m ²

依照下表參數輸入

	Element Type	Horizontal Spacing (m)	D(m)
Nail /Steel	Embedded Truss	2	0.0288

Modulus of Elasticity(E)(kN/m ²)	Poisson's Ratio(v)	Unit Weight(γ)(kN/m ³)	Yield Strength(kN/m ²)
210,000,000	0.3	80	400000



Nail元素生成-1

Model選單> Element

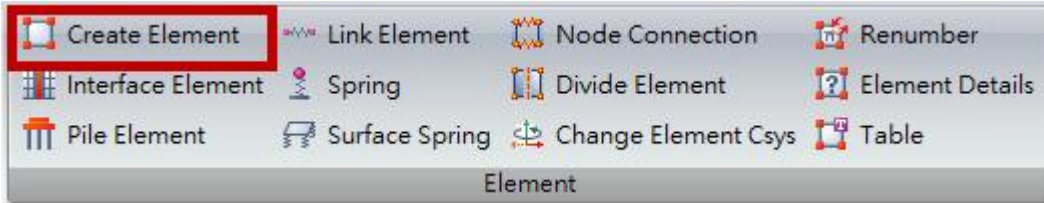

Mesh Set : Nail

Element Type:
Embedded Truss Element

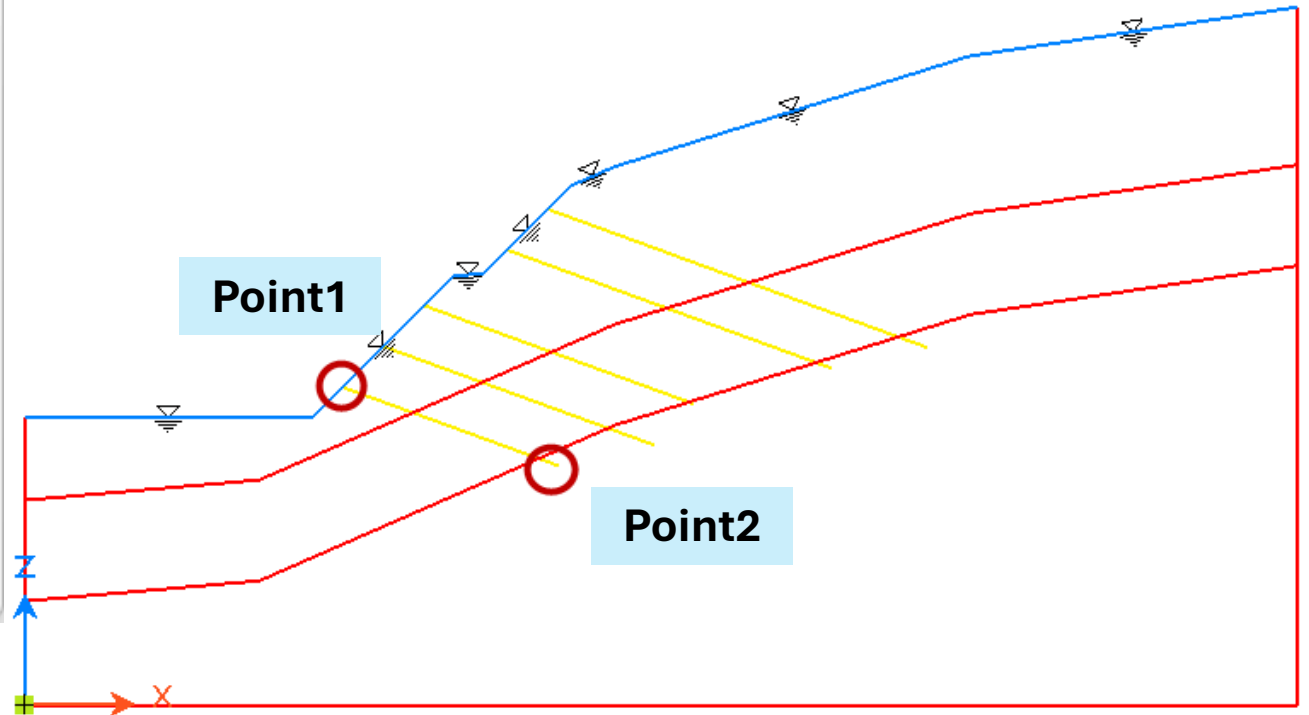
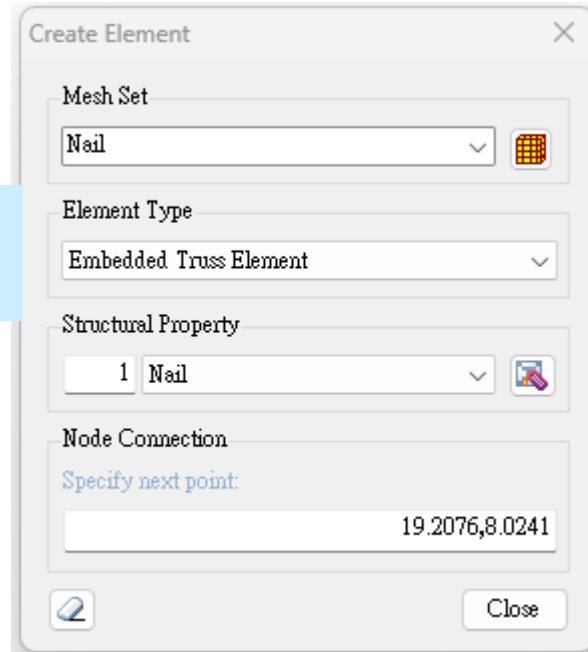

Nail元素生成-2

依序完成其它土釘

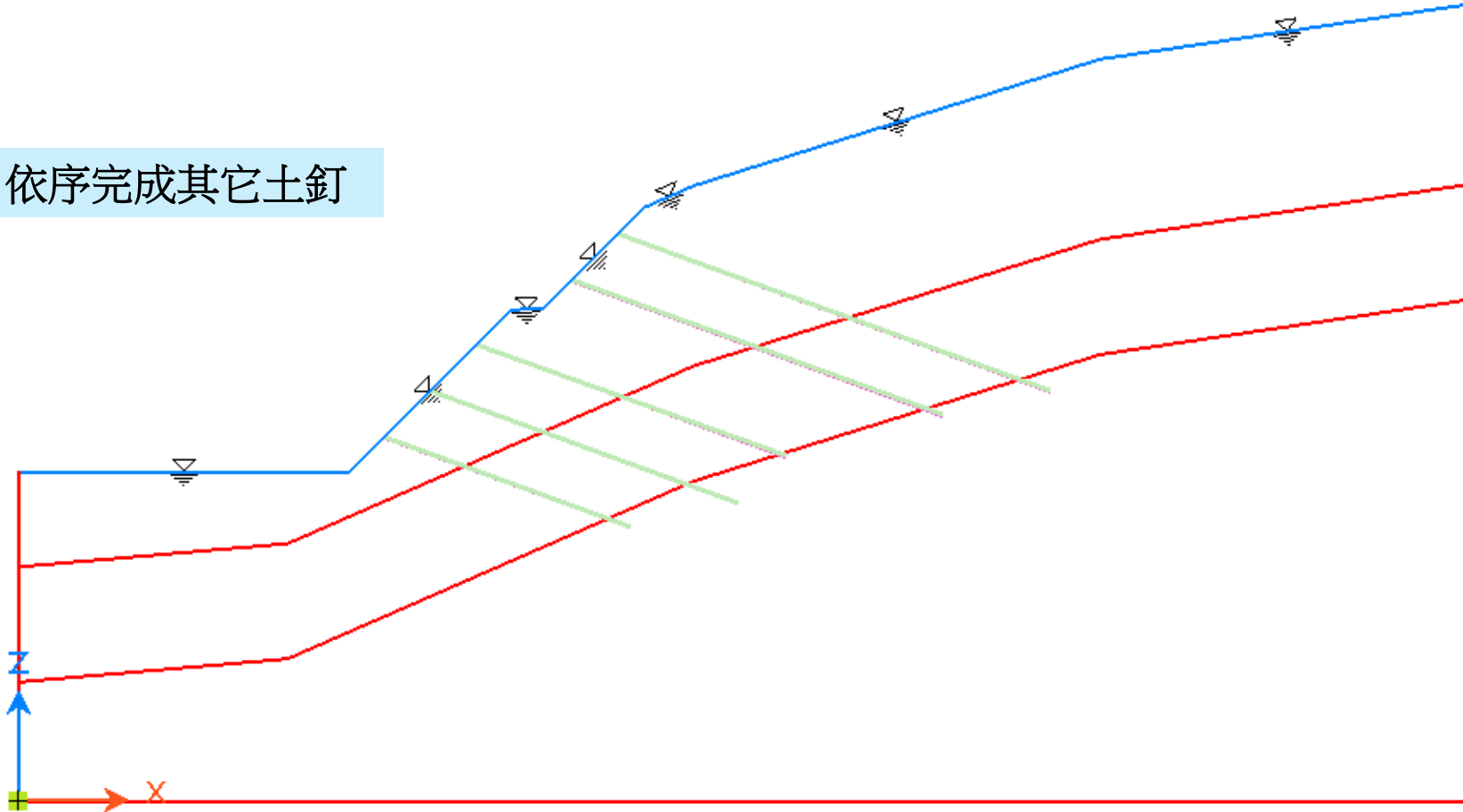

分析定義

(SRM土釘加勁邊坡穩定性分析)

分析名稱:SRM土釘加勁邊坡穩定性分析/分析類型: Strength Reduction Method (SRM)

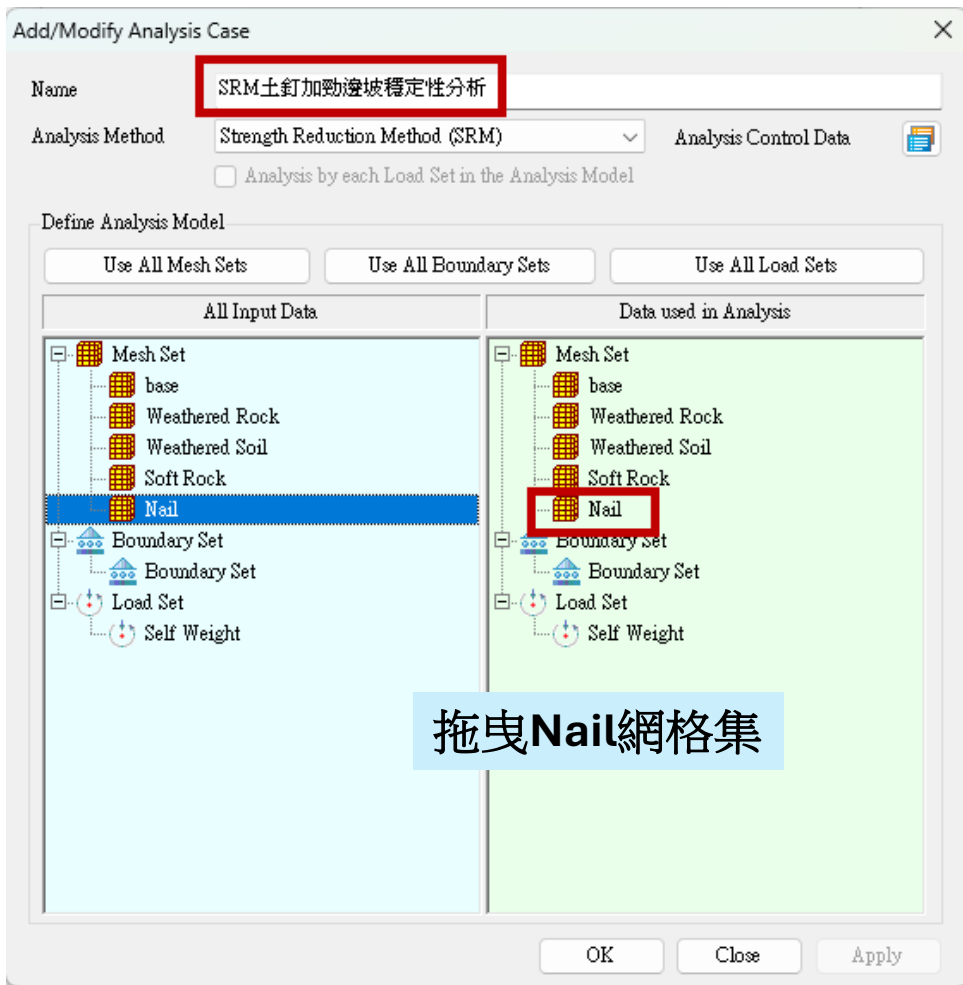
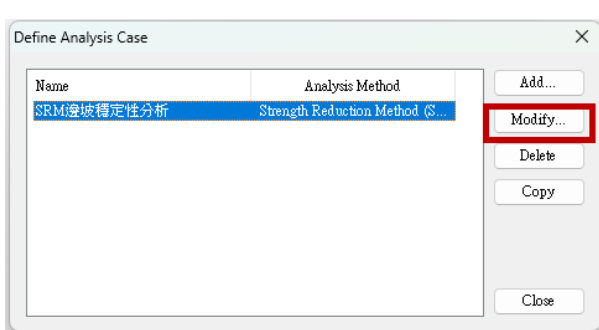
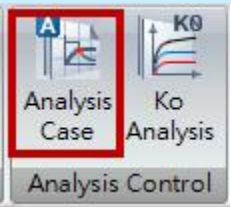

拖曳Nail網格集

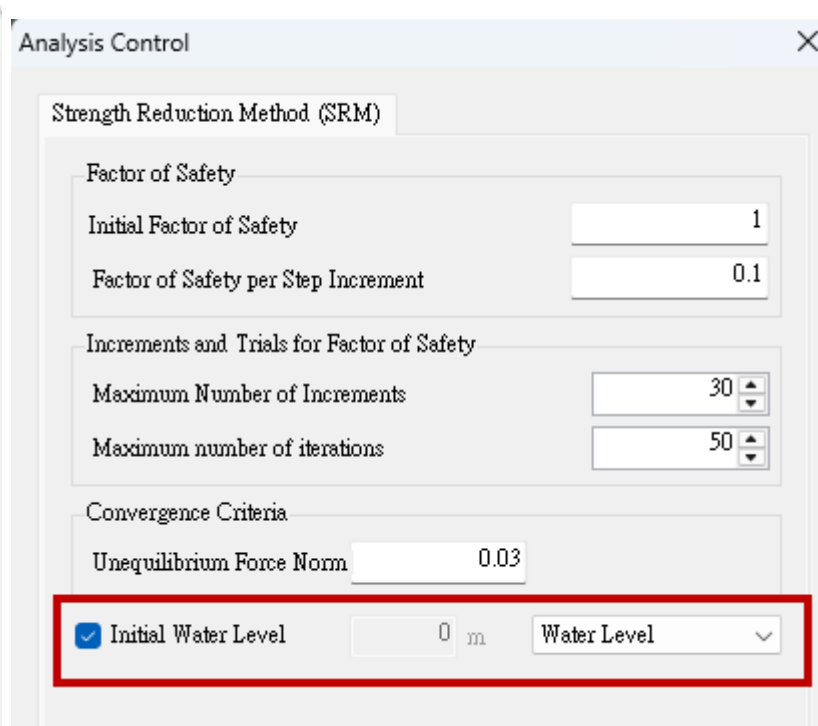

指定水位線



計算

The screenshot displays the SoilWorks software interface for a slope stability analysis. The main window shows a 3D model of a slope with a failure surface. The 'Analysis Manager' dialog box is open, listing the analysis name and type. The 'Perform Analysis' button is highlighted with a red box. The 'Works' tree on the left shows the model's structure, including surfaces, mesh, and material properties. The 'Message' window at the bottom shows the execution commands.

執行求解

計算迭代過程

Name	Analysis Type
SRM土釘加勁邊坡穩定性分析	Strength Reduction Method

Perform Analysis Cancel Analysis Close

Message
Perform PostFigureCommon data (Number=1) has been generated.
Command Command : SAVE
Perform Analysis Case data (Number=1) has been modified.
Command Command : ANALYSISCASE
Command Command : RUNANALYSIS

Command :



SRM分析結果

(SRM土釘加勁邊坡穩定性分析)

輸出結果

SRM透過水平變形和最大剪切應變判斷破壞面

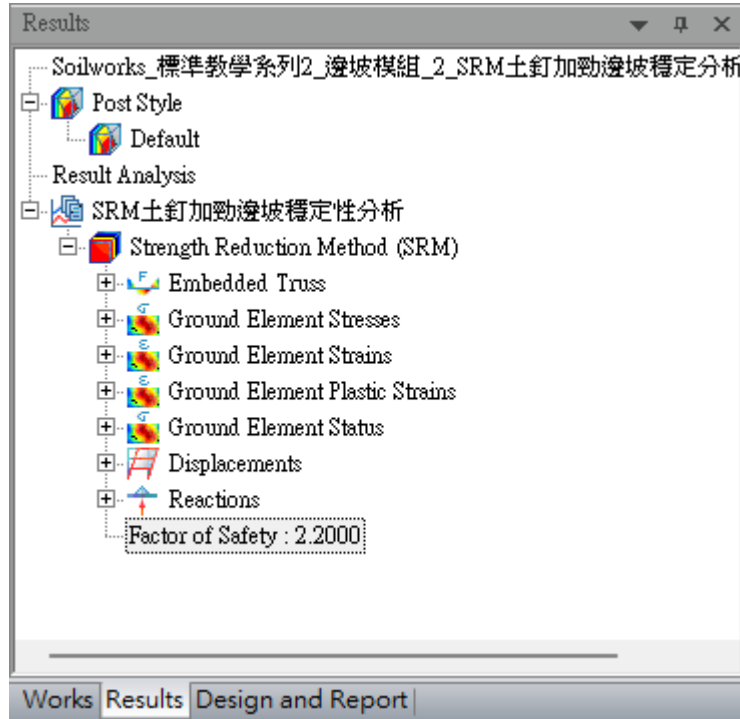

Tx Translation(m)

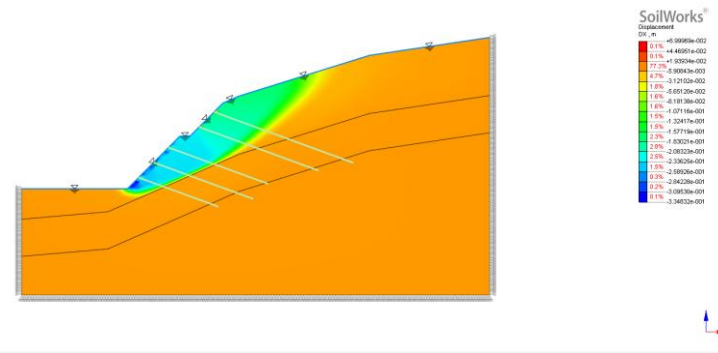

Maximum Shear Strain

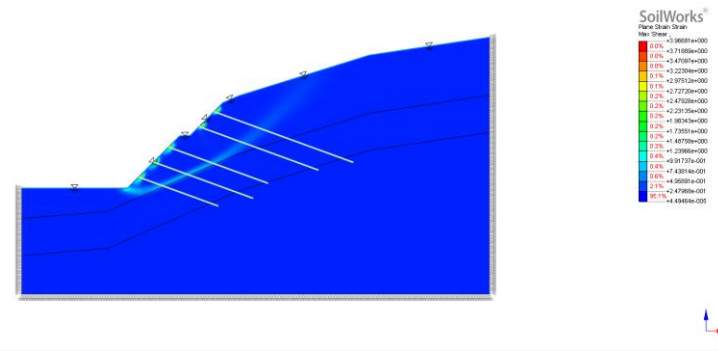

程式會自動輸出安全係數

檔案

SRM土釘加勁邊坡穩定分析_考慮土釘



Part3.SAM土釘加勁邊坡穩定分析

(Stress Analysis Method (SAM)-應力分析法)



Stress Analysis Method (SAM)

(應力分析法)

邊坡穩定性分析大致分為簡化法和數值分析法。極限平衡法(LEM)是解決邊坡穩定問題應用最廣泛的簡化方法，但無法考慮邊坡形成過程中應力歷時的影響以及地下水所造成的地表應力變化。

應力分析法(SAM)，使用有限元素法對斜坡進行應力分析，透過應力分析結果計算極限平衡法假設的多個潛在滑動面的安全係數，確定最小安全係數和相應的臨界截面。有限元素方法中所使用的安全係數定義為：

$$F_s = \frac{\int_S \tau_f d\Gamma}{\int_S \tau_m d\Gamma}$$

$$\tau_f = c + \sigma_n \tan \phi$$

$$\tau_m = \frac{1}{2}(\sigma_y - \sigma_x) \sin 2\theta + \tau_{xy} \cos 2\theta$$

$$\sigma_n = \sigma_x \sin^2 \theta + \sigma_y \cos^2 \theta - \tau_{xy} \sin 2\theta$$

τ_f : 根據莫爾庫侖失效準則計算的剪切強度

τ_m : 誘導剪切強度

σ_n : 垂直於滑動表面的應力

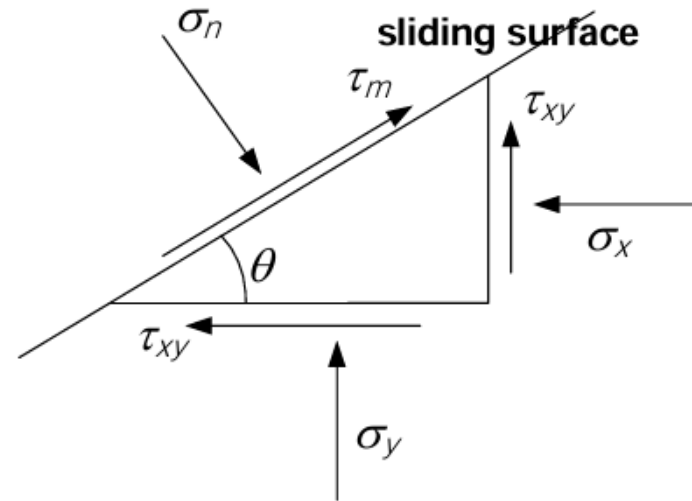

邊坡(Slope)模組



選擇邊坡(Slope)模組



單位切換

The screenshot displays the MIDAS Gen software interface. The main window shows a project tree on the left and a central workspace. Two dialog boxes are open:

- Define Initial Parameters:** A dialog box with a title "使用者自訂使用單位" (User-defined units). It shows the "Unit System" set to "User Defined...". The "Force" unit is set to "kN", "Length" to "m", and "Time" to "sec". Other parameters include "Gravitational Acceleration" (9.807 m/sec²), "Unit Weight of Water" (9.807 kN/m³), and "Initial Temperature" (0.000 [T]).
- Unit settings:** A dialog box with a title "單位使用KN/m/sec" (Unit use KN/m/sec). It shows the "Force Unit [F]" set to "kN", "Length Unit [L]" set to "m", and "Time Unit [T]" set to "sec".

A 3D coordinate system with X, Y, and Z axes is visible in the workspace.



新增土釘圖層

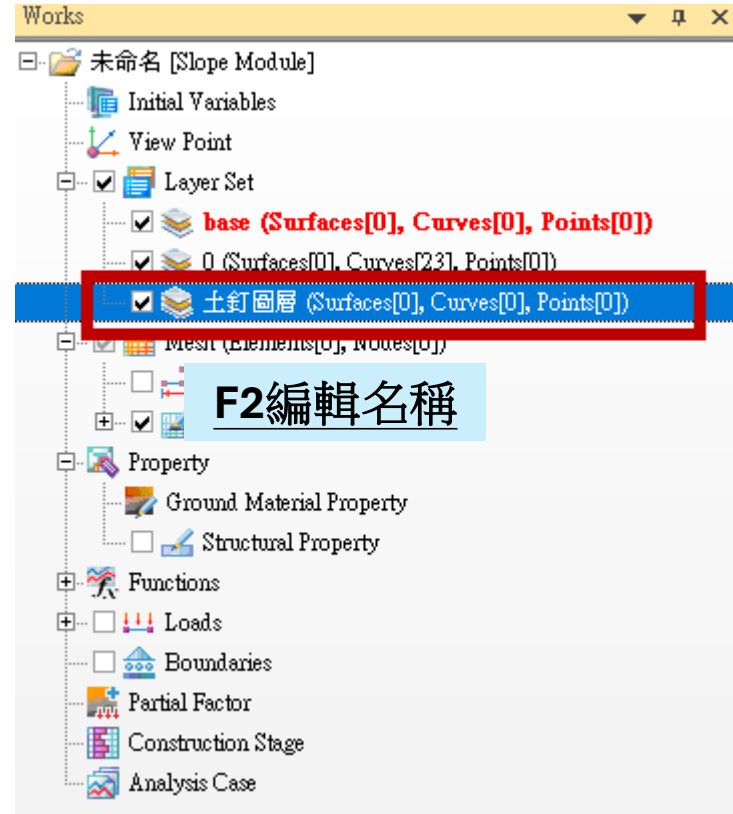
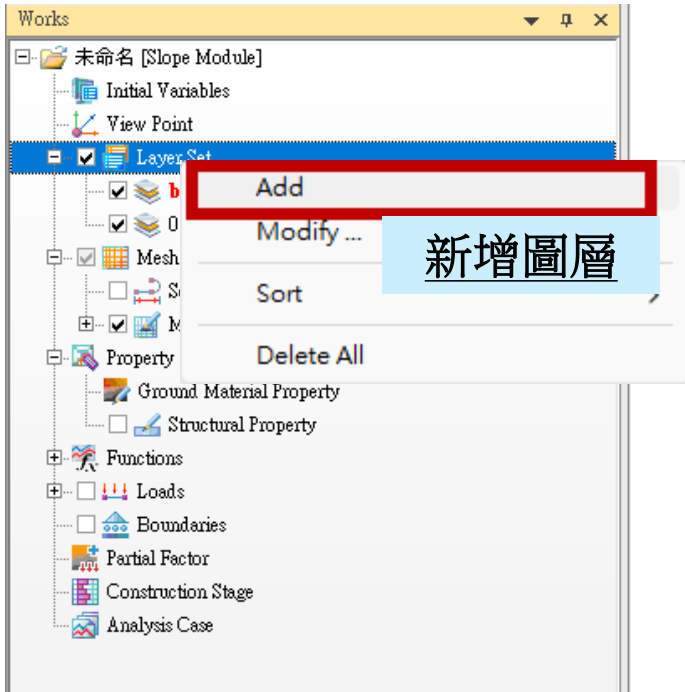

土釘圖層編輯

Select Filter 切換到 Curve

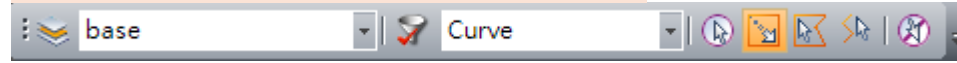

移動土釘特徵到土釘圖層

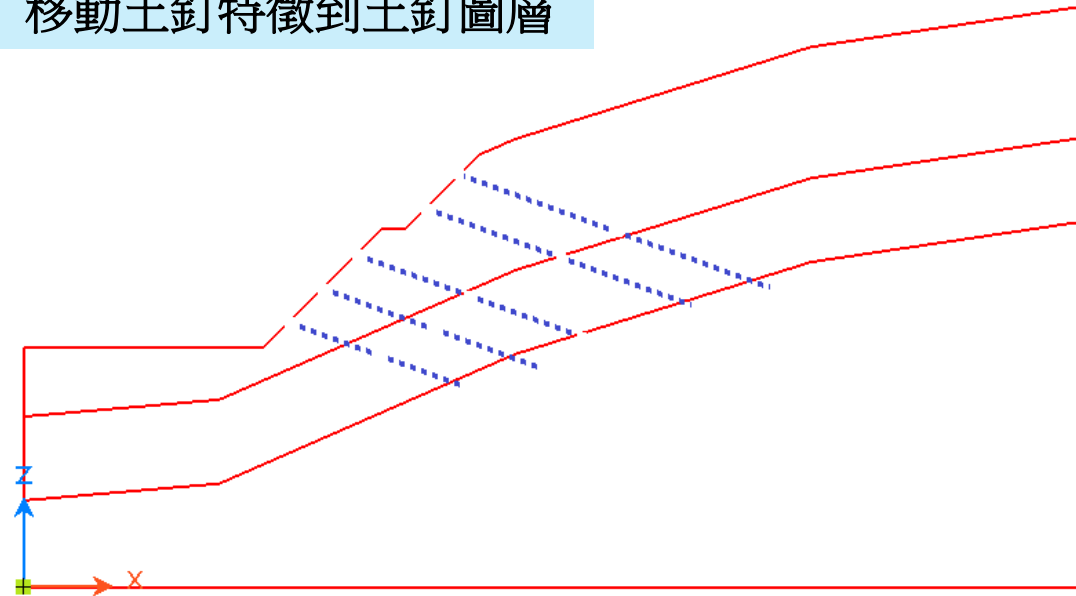
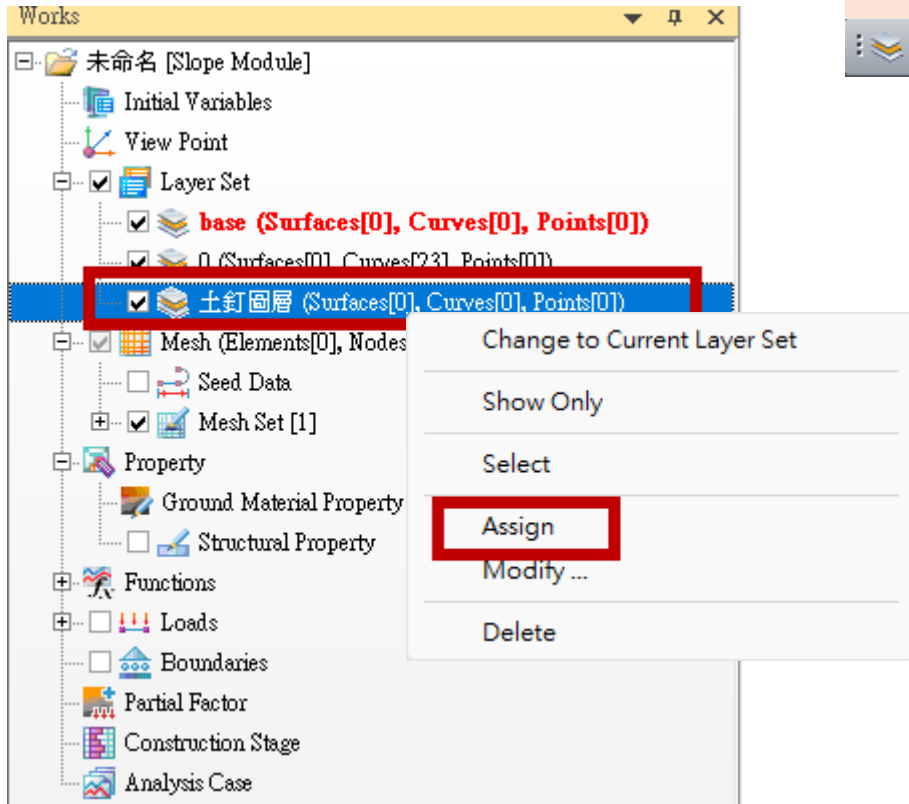

Geometry 選單>Smart Surface

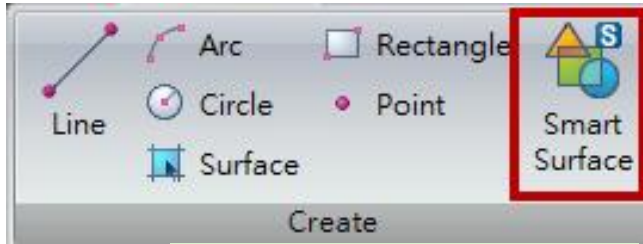

自動生成面特徵

隱藏土釘圖層

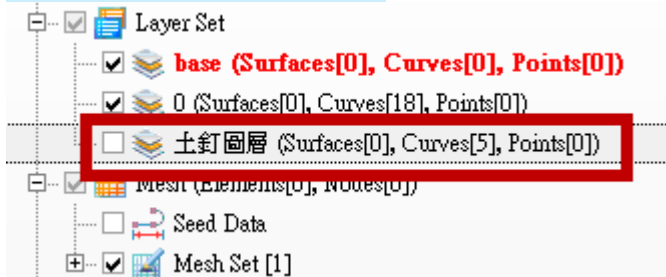

面特徵建立

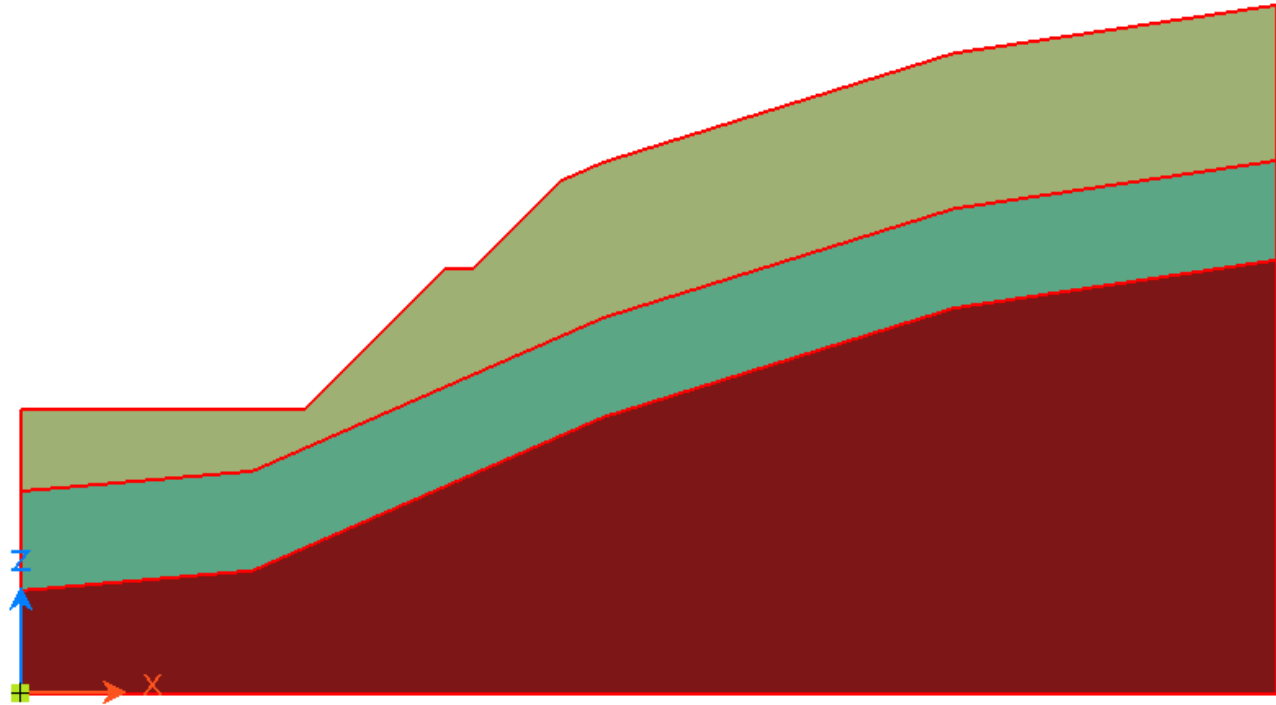

Layer Color(顏色顯示方式)

土壤材料屬性(Soilworks材料庫)

Model

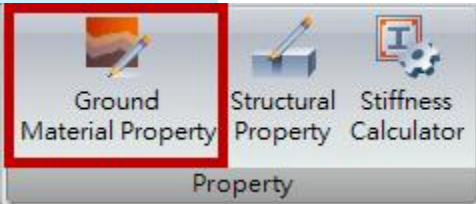

選取 1.1schist#1 類別

Ground Material Database

Database: 1.1 Schist#1

No.	Soil Type	Modulus of Elasticity (kN/m ²)	Unit Weight (kN/m ³)	Saturated Unit Weight (kN/m ³)	Poisson's Ratio	Cohesion (kN/m ²)	Internal Friction Angle	Select
1	Landfill Layer	13000	18	19	0.33	0	27	<input type="checkbox"/>
2	Alluvial Layer	8000	17	18	0.35	15	20	<input type="checkbox"/>
3	Weathered Soil	36500	18.5	19.5	0.33	17.5	31	<input checked="" type="checkbox"/>
4	Weathered Ro	150000	21	22	0.3	50	33	<input checked="" type="checkbox"/>
5	Soft Rock	1850000	24	25	0.28	180	35.5	<input checked="" type="checkbox"/>
6	Hard Rock	17500000	26	27	0.23	1750	40.5	<input type="checkbox"/>

選取 No3~No5

Assign新增材料

Reset Save Model Type: Mohr-Coulomb Assign Close

Define Ground Material Property

Data: ID 1 Name

General: Model Type: Mohr-Coulomb

General Parameters:

Modulus of Elasticity (E)	20000000	kN/m ²
Poisson's Ratio (u)	0.3	
Temperature Coeff. (a)	1E-06	
Unit Weight (Yt)	20	kN/m ³
Saturated Unit Weight	21	kN/m ³
Cohesion (c)	30	kN/m ²
Internal Friction Angle (Φ)	36	[deg]
Earth Pressure Coeff. (Ko)	1	
Draining Condition	Drained	

Additional Parameters:

Variation in Modulus of Elasticity	0	kN/m ²
Variation in Cohesion	0	kN/m ²
Reference Height	0	m
<input type="checkbox"/> Dilatancy Angle (ψ)	36	[deg]
<input type="checkbox"/> Tensile Strength	2000	kN/m ²

Database ... Material Statistic Add Modify Delete Close

Soilworks材料庫

完成Mohr-Coulomb土壤材料新增



顏色顯示(補充)

自訂屬性顏色

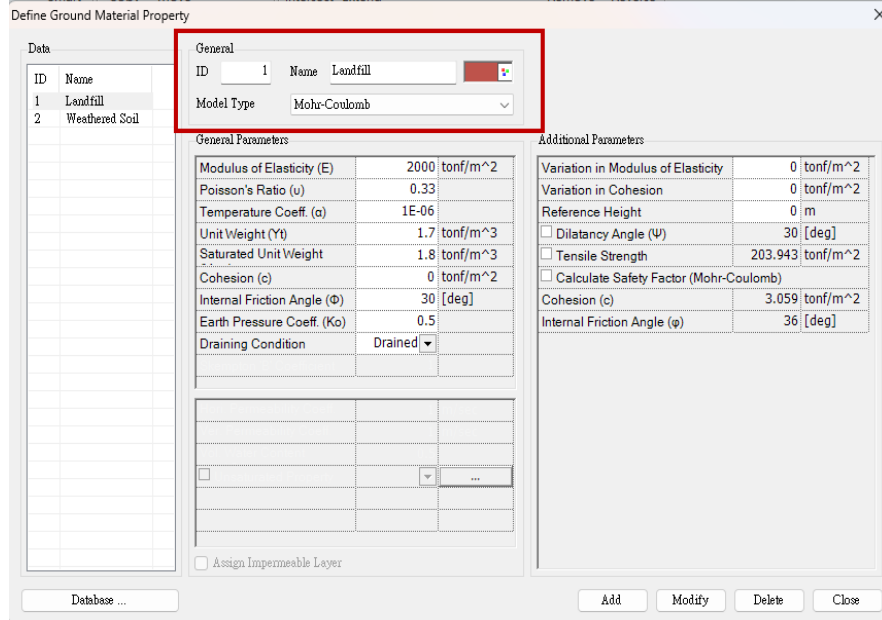

Display Setting顯示設定

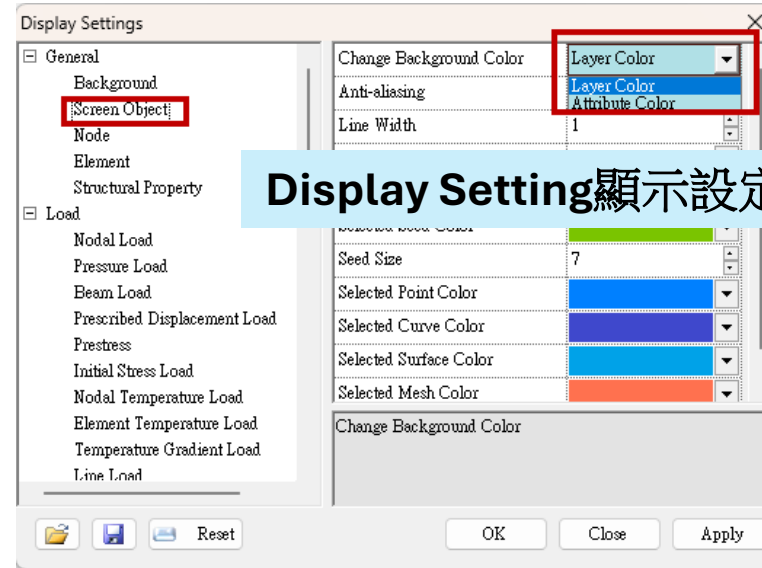

Display Setting顯示設定

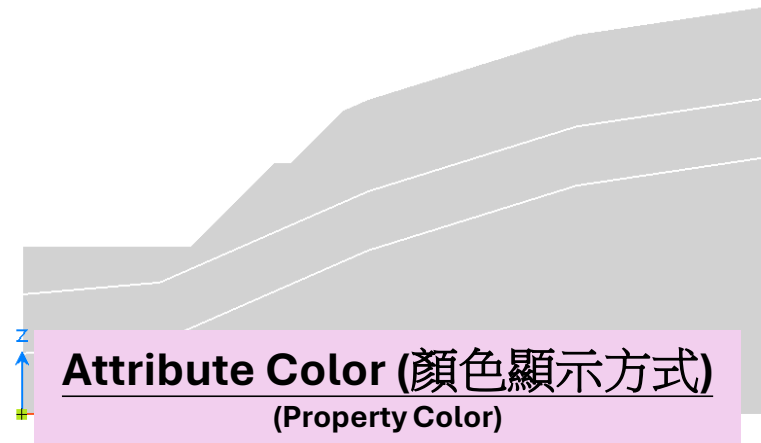

土壤材料屬性指定

Select Filter 切換到 Surface

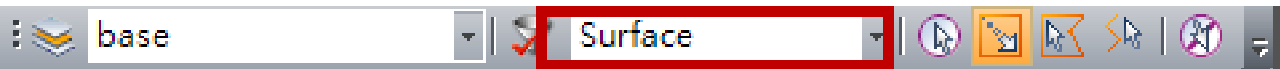

框選 Weathered Soil 分布區域特徵

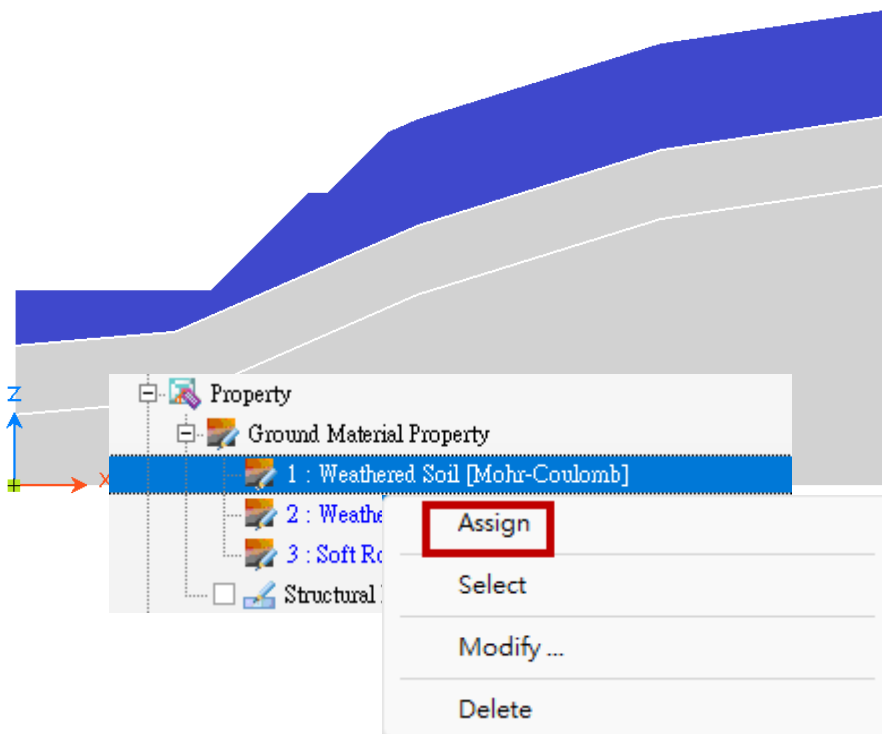

框選 Weathered Rock 分布區域特徵

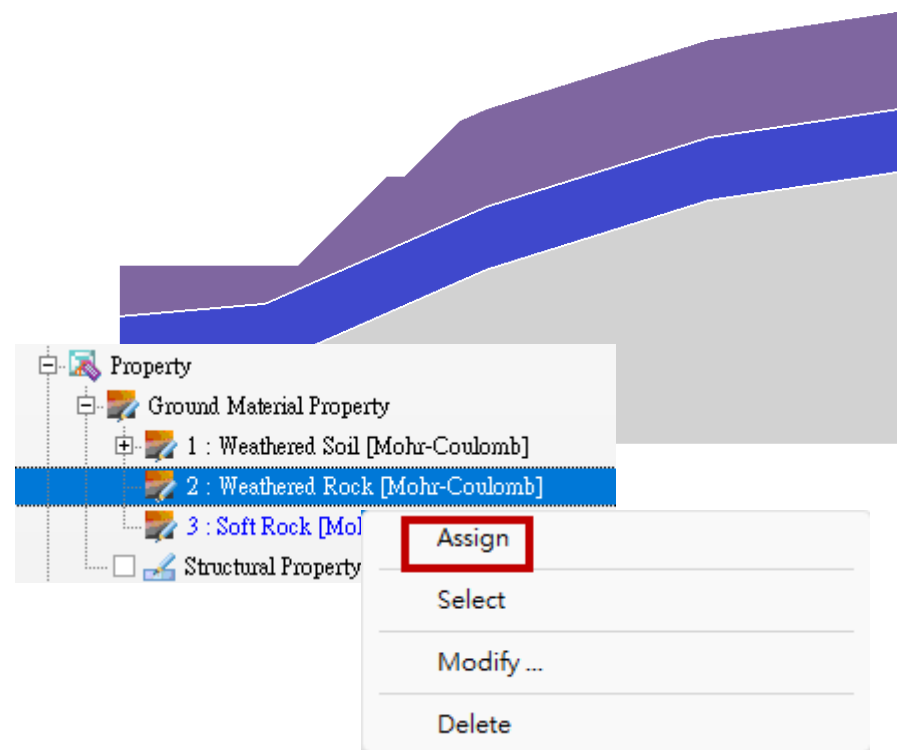

土壤材料屬性指定

Select Filter 切換到 Surface

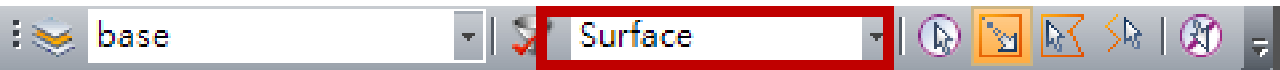

框選 Soft Rock 分布區域特徵

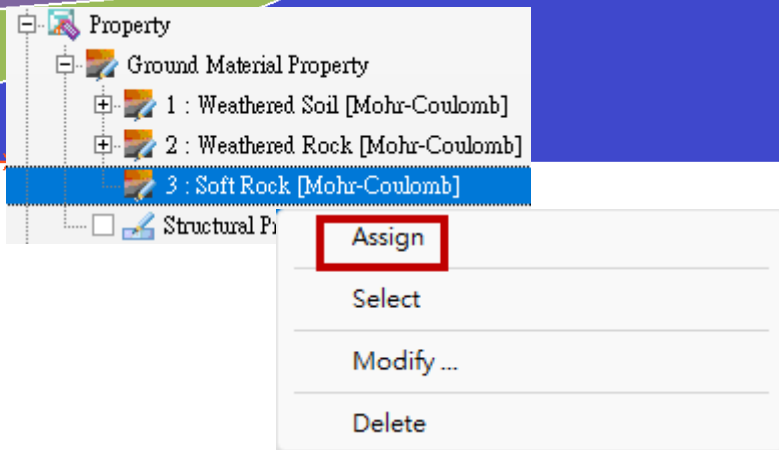
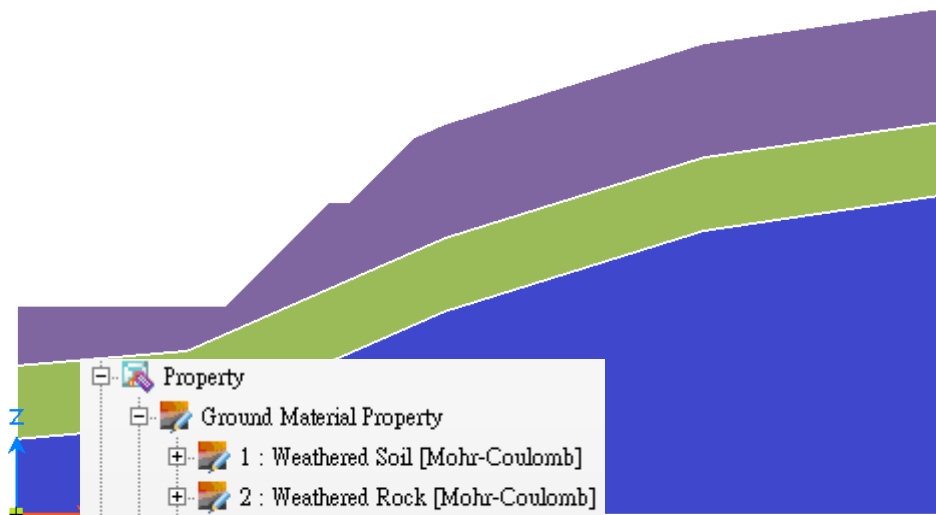

Ground Material Property 模型樹顯示指定特徵數量

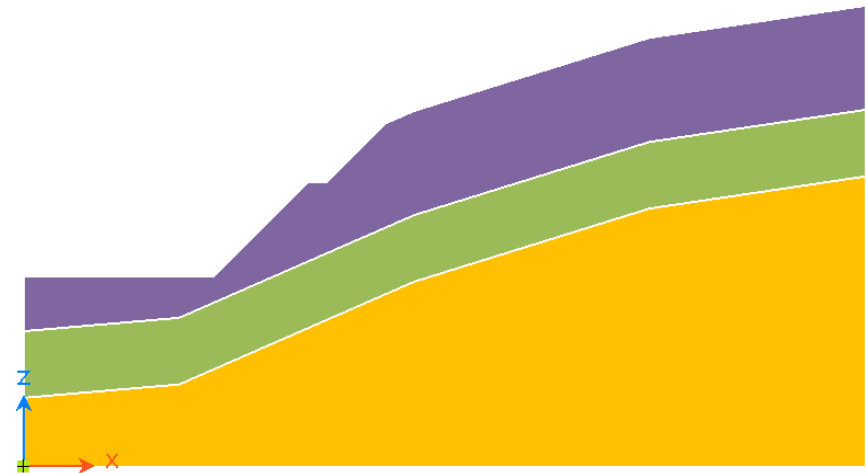
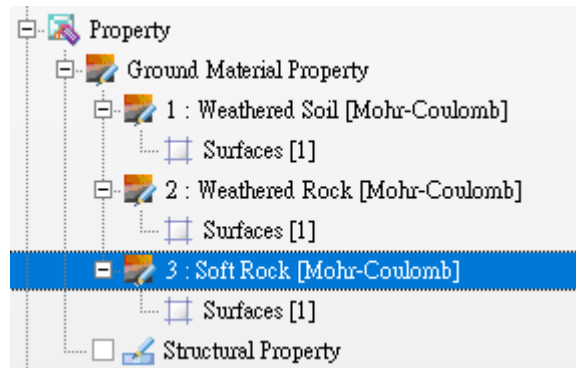

Model選單> Mesh

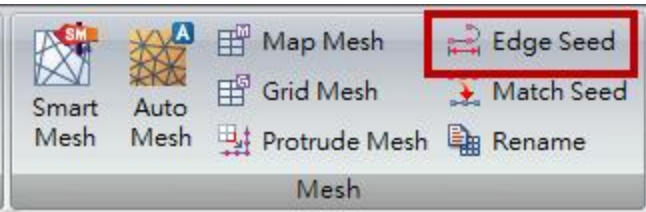

指定網格尺寸

Select Filter 切換到 Curve

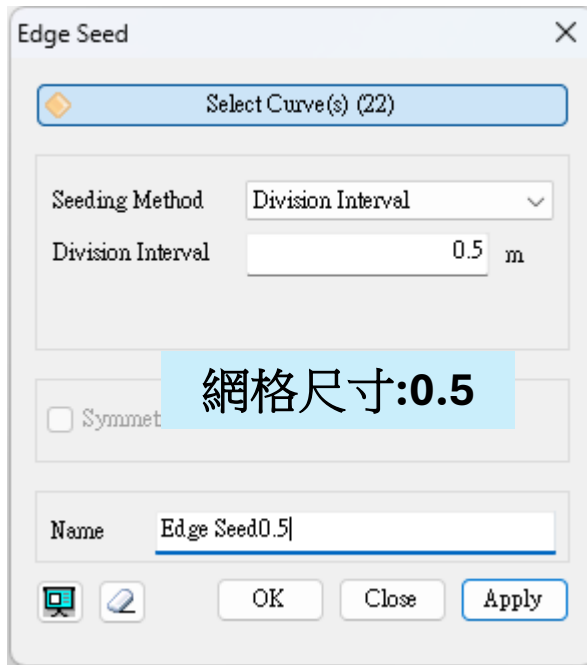
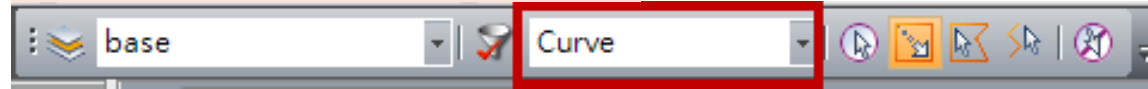

框選所有線特徵

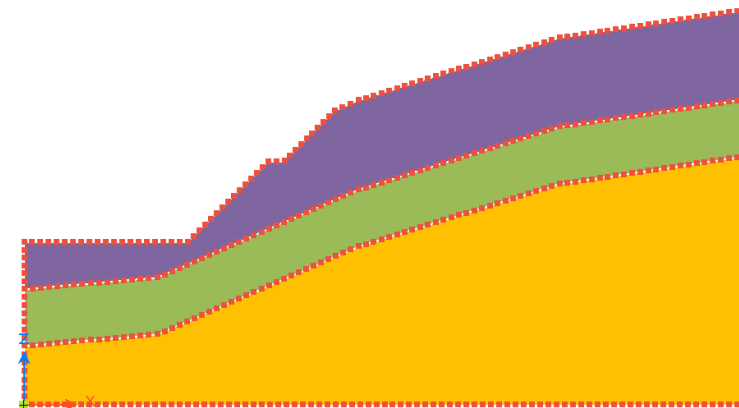
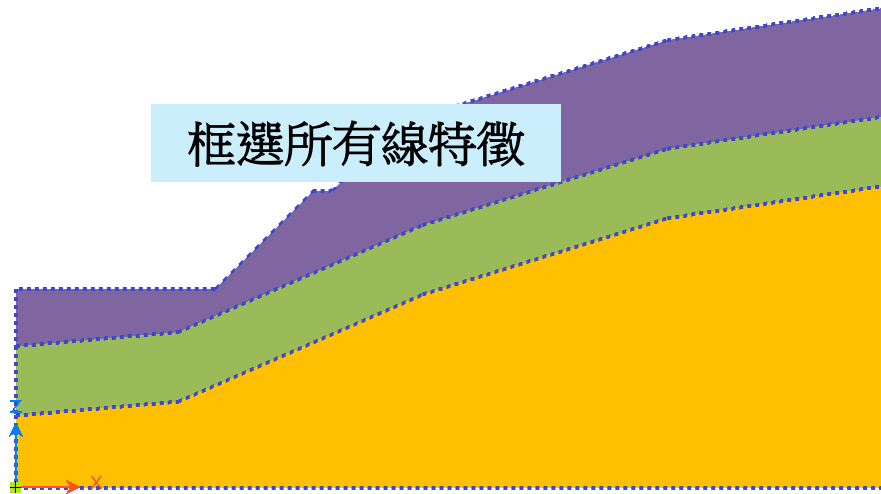

Model選單> Mesh

2D網格生成

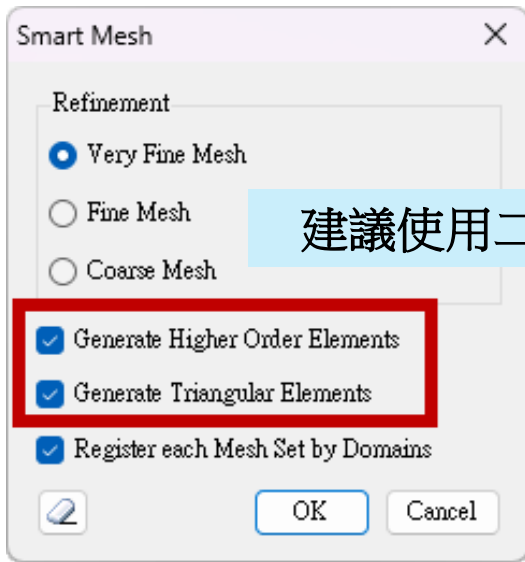
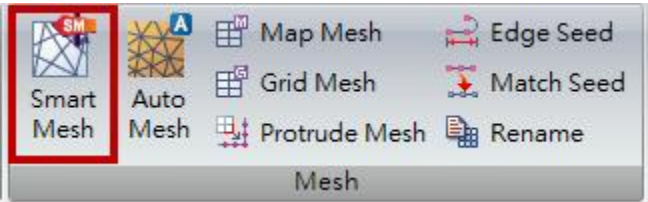

建議使用二階&三角形元素

每個面特徵各別生成網格集

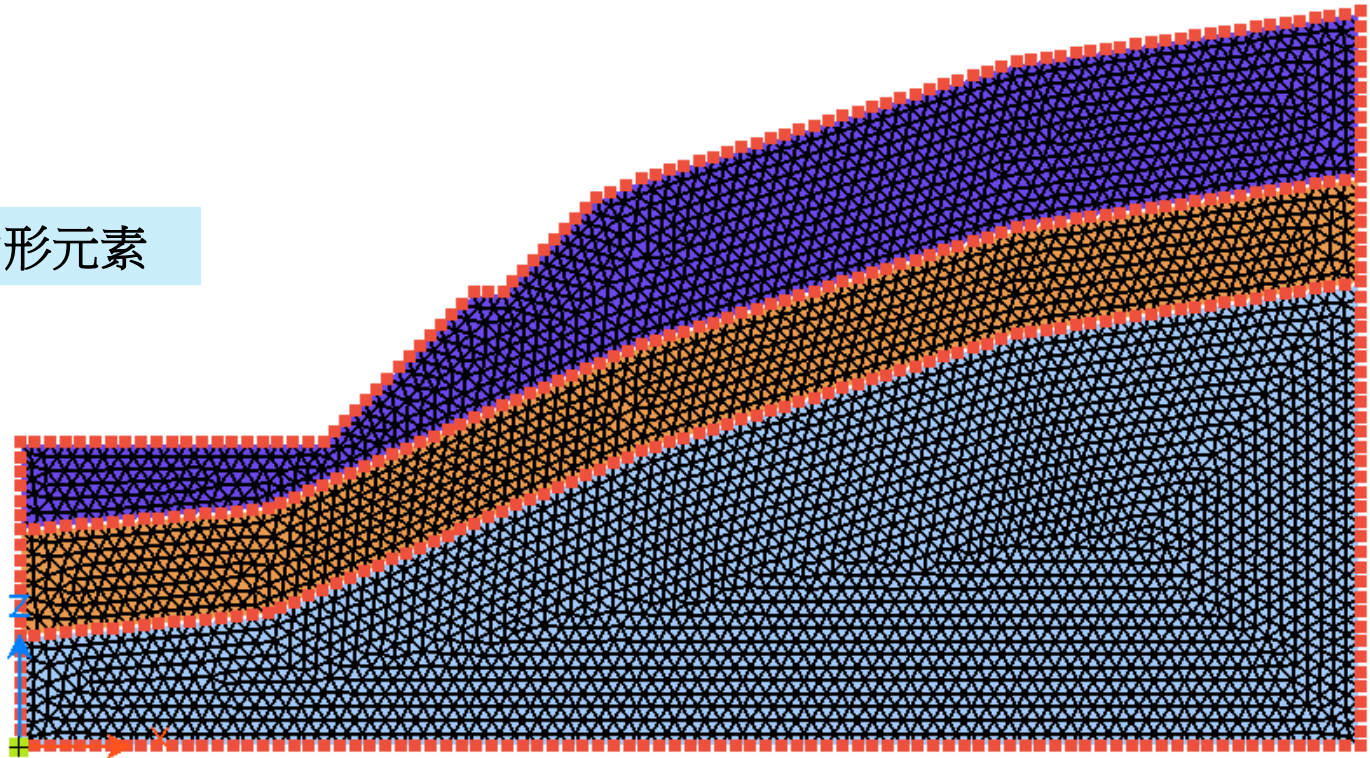

水位線

Loads | Boundaries



Water Level

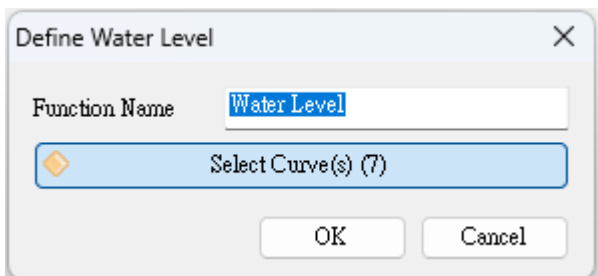

Select Filter 切換到 Curve

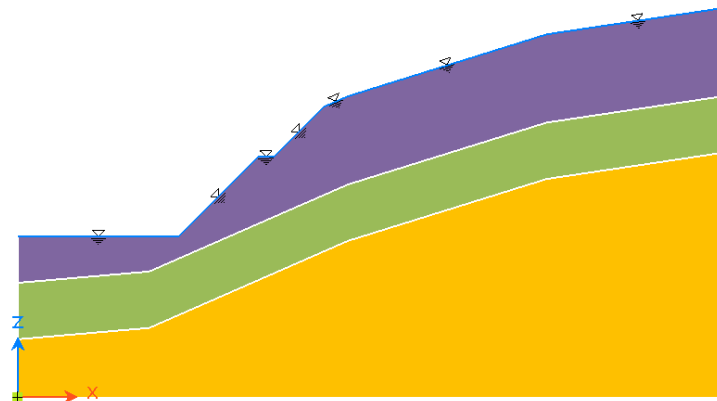
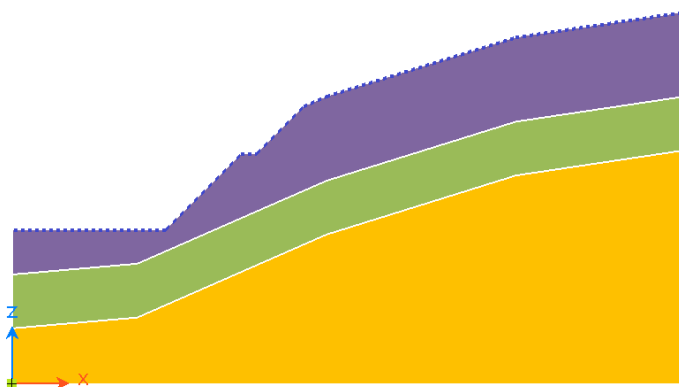
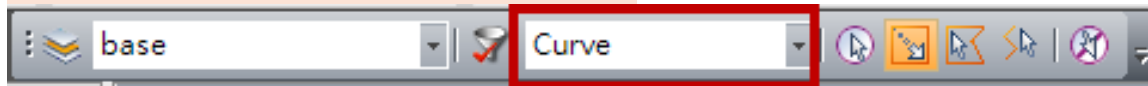

Limit Equilibrium Method

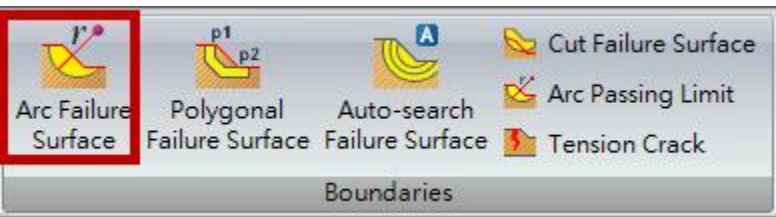

破壞面-1

(Arc Failure Surface-Grid Data)

圓弧中心區域定義

自訂Boundary Set名稱:ARC

Grid Data

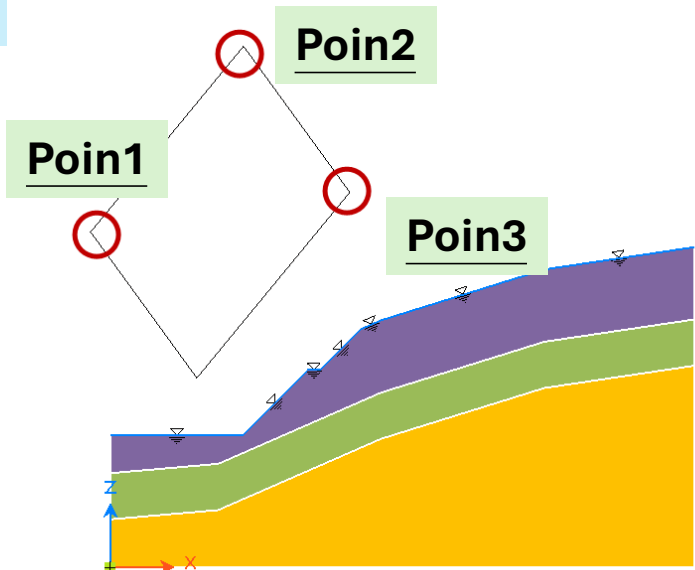
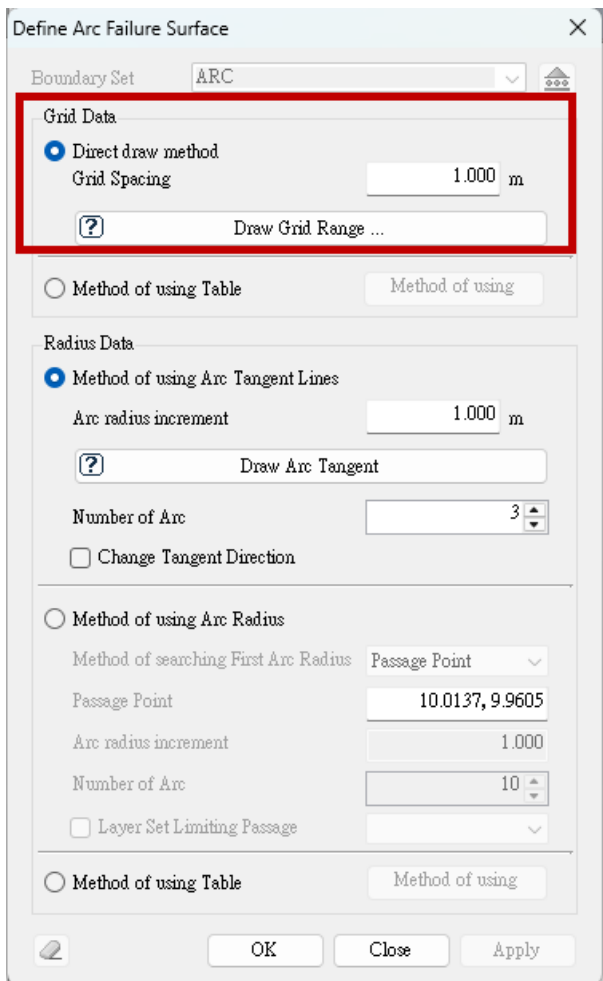

Draw Grid Range
依照順序空間點選Point1~Point3

預設節點間隔(1m)

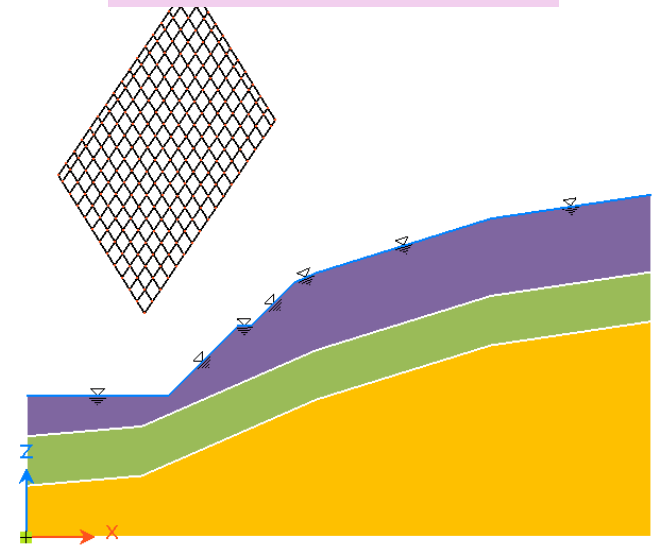

破壞面-2

(Arc Failure Surface-Radius Data)

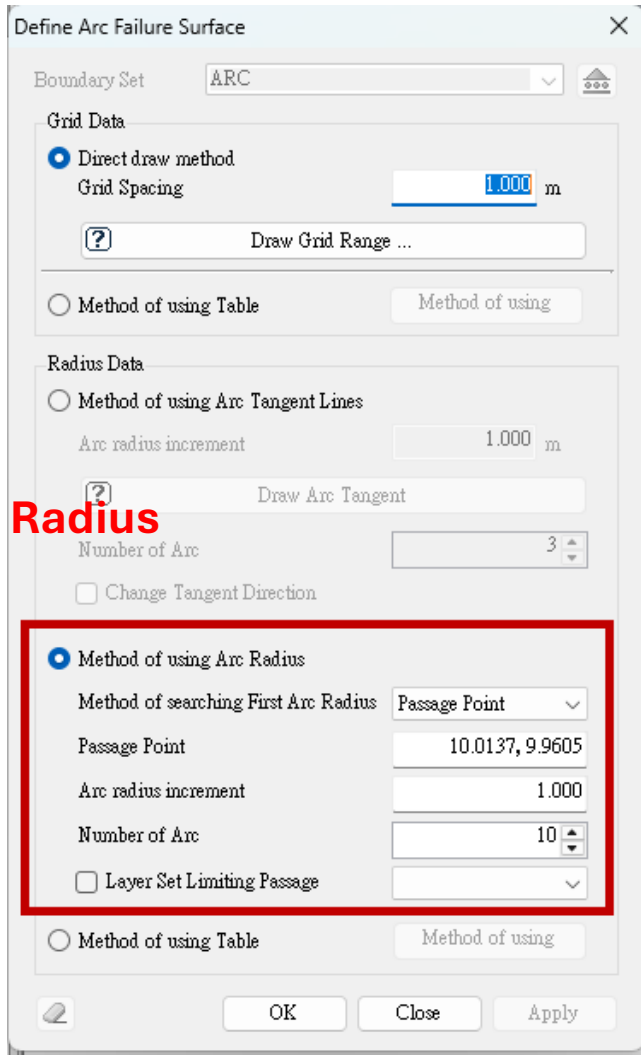

Radius Data
Method of Arc Radius

破壞面區域定義

預設採Arc Tangent Method

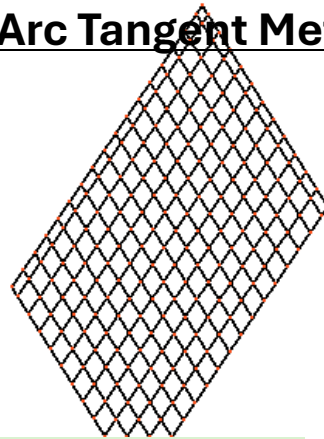

passage point

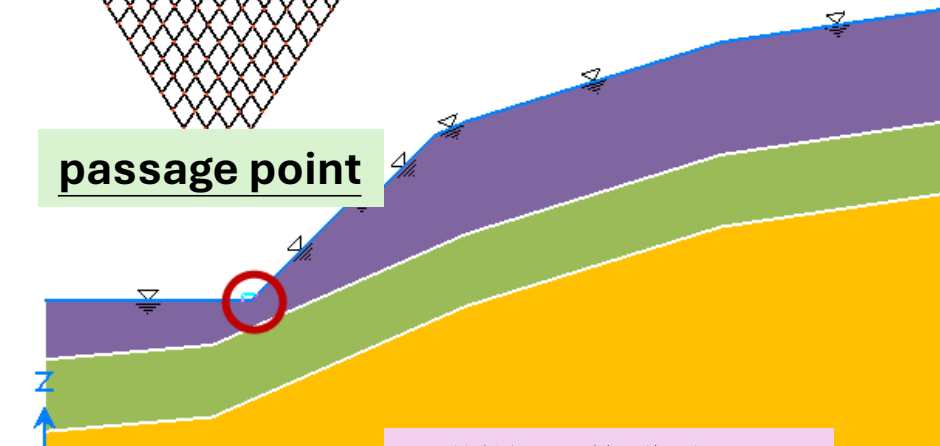

調整圓弧數(10)

預設圓弧間隔(1m)

拘束條件

(自動判斷)

Loads | Boundaries 選單

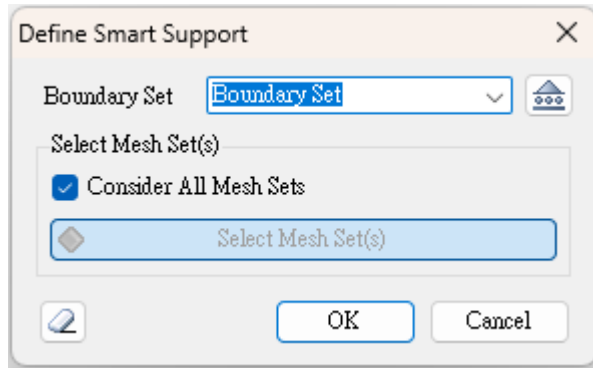

自動施加拘束條件

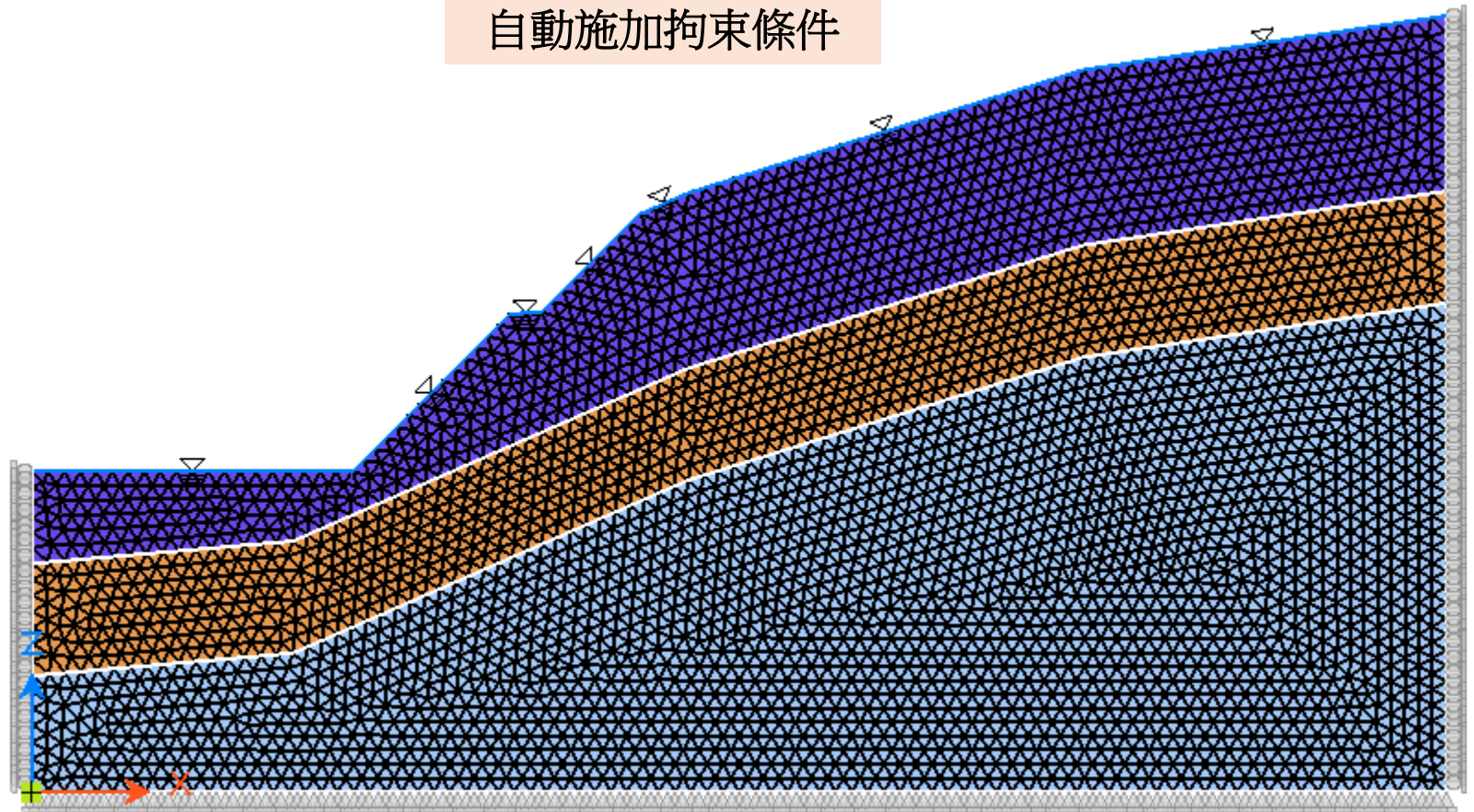

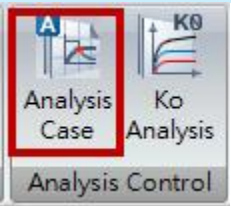

分析定義 (SAM邊坡穩定性分析)

分析名稱: SAM邊坡穩定性分析 / 分析類型: Stress Analysis Method (SAM)

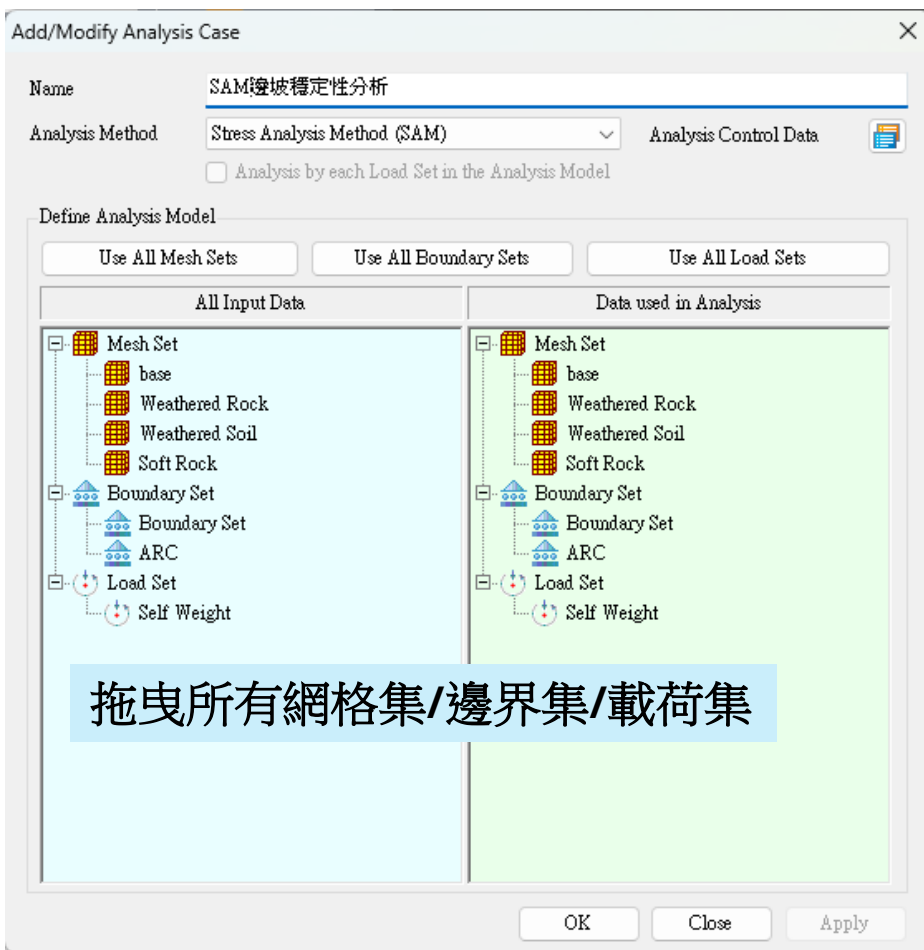
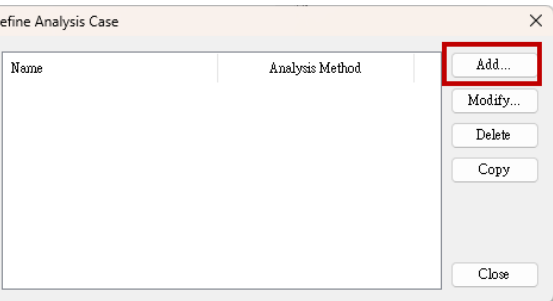

拖曳所有網格集/邊界集/載荷集

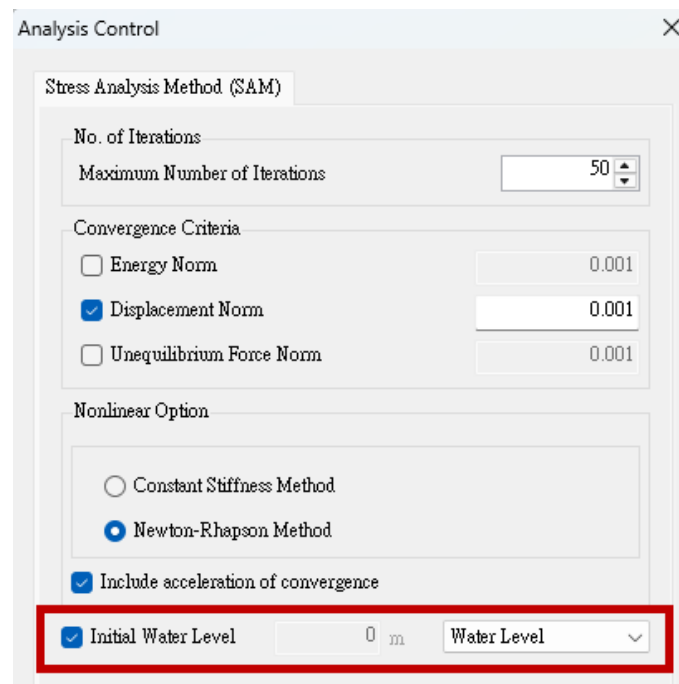

指定水位線



計算

SoilWorks - Soilworks_標準教學系列2_邊坡模組_2_SAM土釘加勁邊坡穩定分析_未考慮土釘 [Slope Module]

Geometry Limit Equilibrium Method Model Loads | Boundaries Analysis Design Results Tools Window

Partial Factor Construction Stage Stage Simulate Analysis Design Analysis and Report
Factor Stage Models Construction Stages Case Options and Report
Construction Stage Design and Rep... Run

Works base Surface

SoilWorks Shared Information Model Data

Initial Variables
View Point
Layer Set
base (Surfaces[0], Curves[0], Points[0])
0 (Surfaces[0], Curves[22], Points[0])
土釘圖層 (Surfaces[0], Curves[5], Points[0])
Smart Surface 1 (Surfaces[1], Curves[0], Points[0])
Smart Surface 2 (Surfaces[1], Curves[0], Points[0])
Smart Surface 3 (Surfaces[1], Curves[0], Points[0])
Mesh (Elements[7224], Nodes[15073])
Seed Data
Mesh Set [4]
base (Elements[0], Nodes[0])
Weathered Rock (Elements[1454], Nodes[31])
Weathered Soil (Elements[1796], Nodes[379])
Soft Rock (Elements[3974], Nodes[8167])
Property
Ground Material Property
1 : Weathered Soil [Mohr-Coulomb]
2 : Weathered Rock [Mohr-Coulomb]
3 : Soft Rock [Mohr-Coulomb]
Structural Property
Functions
Loads
Boundaries
Partial Factor
Construction Stage
Analysis Case

Analysis Manager

<input checked="" type="checkbox"/>	Name	Analysis Type
<input checked="" type="checkbox"/>	SAM邊坡穩定性分析	Stress Analysis Method (SAM)

執行求解

Perform Analysis Cancel Analysis Close

Message
Perform PostFigureCommon data (Number=1) has been generated.
Command Command : SAVE
Perform Analysis Case data (Number=1) has been modified.
Command Command : ANALYSISCASE
Command Command : RUNANALYSIS

Works Results | Design and Report | Command :
Ready 0% X: -3.6248 m Z: 35.3686 m GRID OSNAP ORTHO kN m



SAM分析結果

輸出結果

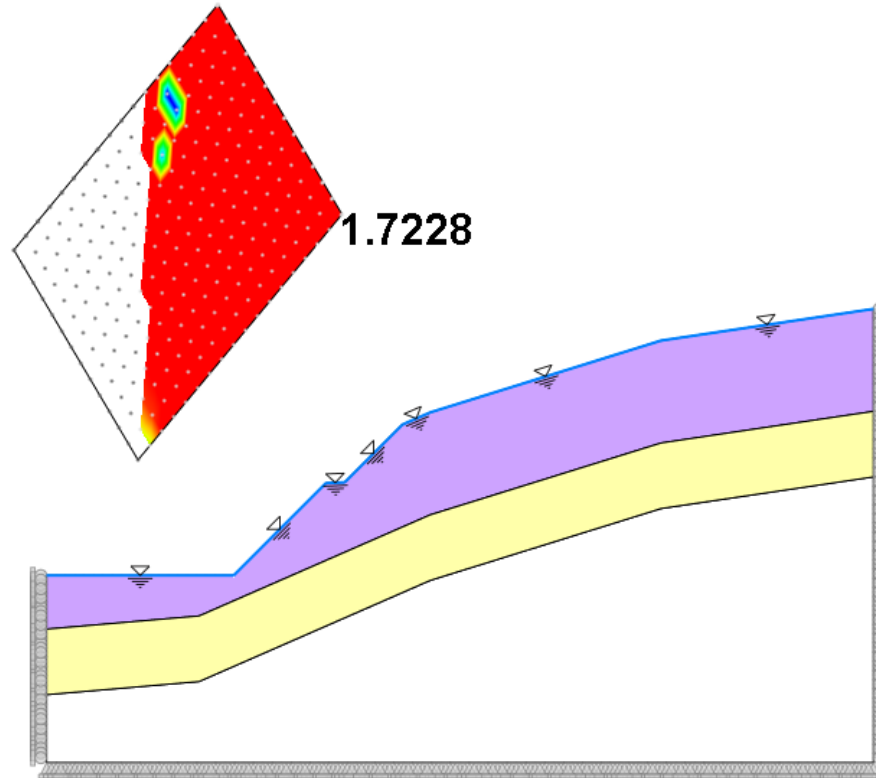

SoilWorks®

Safety Factor	
1.8%	+1.60586e+002
1.8%	+1.50657e+002
2.9%	+1.40726e+002
2.9%	+1.30799e+002
2.9%	+1.20870e+002
2.9%	+1.10941e+002
2.9%	+1.01012e+002
2.9%	+9.10833e+001
2.9%	+8.11544e+001
2.9%	+7.12254e+001
2.9%	+6.12965e+001
3.5%	+5.13675e+001
4.1%	+4.14386e+001
3.5%	+3.15096e+001
3.5%	+2.15807e+001
4.7%	+1.16517e+001
53.4%	+1.72275e+000

程式會自動輸出安全係數

檔案

SAM土釘加勁邊坡穩定分析_未考慮土釘



結構屬性-Nail

Model選單>Property



General

ID 1 Name Nail

Element Type Embedded Truss

Standard NONE

Horizontal Spacing 2 m

Section

Shape Round Tapered Section

Sub-Shapes U Type

Section User Defined

Section-2 User Defined

Material

Material Type Steel

Concrete User Defined

SteelGrade User Defined

自訂名稱:Nail

Section Data Material Data

Section Section-2 Stiffness

Section

D 0.0288 m

Stiffness Calculation

Area 0.000651 m²

依照下表參數輸入

Section Data Material Data

User Defined Steel

Properties

Modulus of Elasticity	210000000 kN/m ²
Poisson's Ratio	0.3
Unit Weight	80 kN/m ³
Thermal Coefficient	0.000012
Design Strength	
Yield Strength	400000 kN/m ²

依照下表參數輸入

	Element Type	Horizontal Spacing (m)	D(m)
Nail /Steel	Embedded Truss	2	0.0288

Modulus of Elasticity(E)(kN/m ²)	Poisson's Ratio(v)	Unit Weight(γ)(kN/m ³)	Yield Strength(kN/m ²)
210,000,000	0.3	80	400000



Nail元素生成-1

Model選單> Element

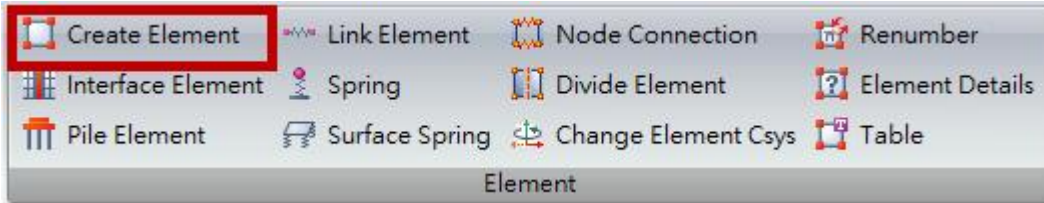

Mesh Set : Nail

Element Type:
Embedded Truss Element

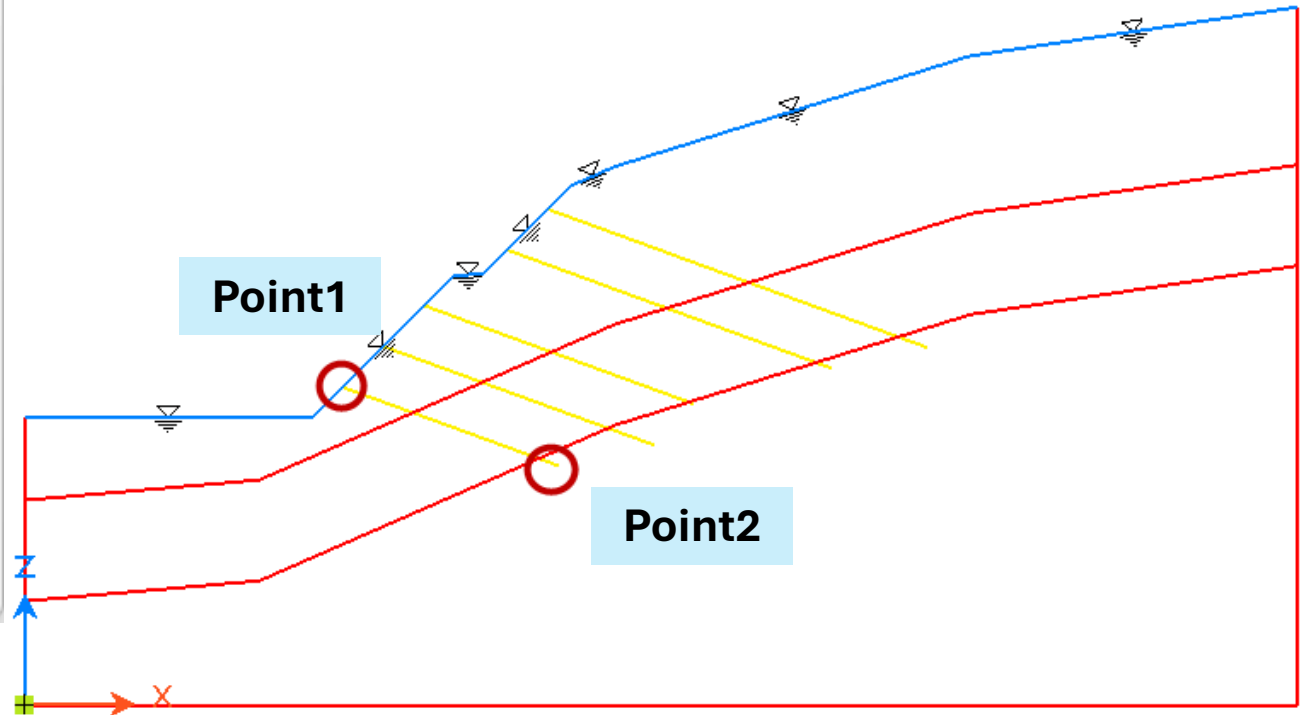
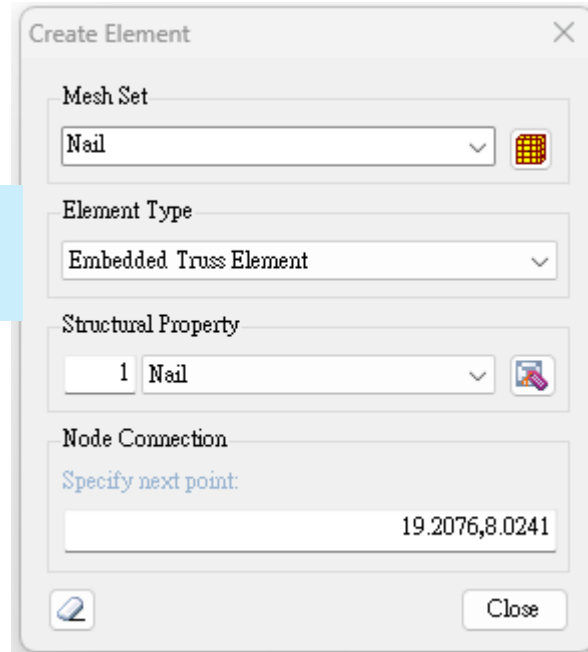

Nail元素生成-2

依序完成其它土釘

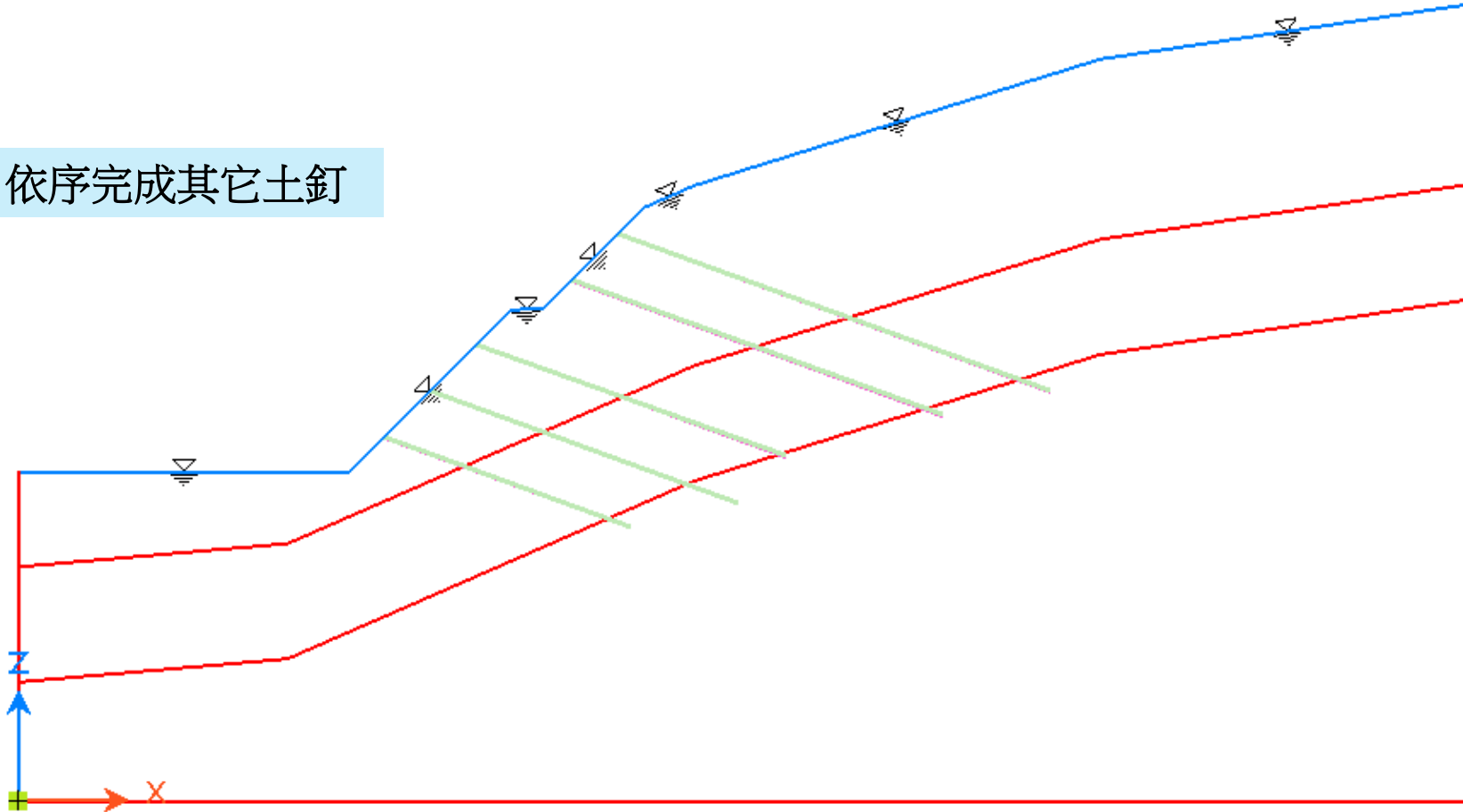

分析定義

(SAM土釘加勁邊坡穩定性分析)

分析名稱: SAM土釘加勁邊坡穩定性分析 / 分析類型: Stress Analysis Method (SAM)

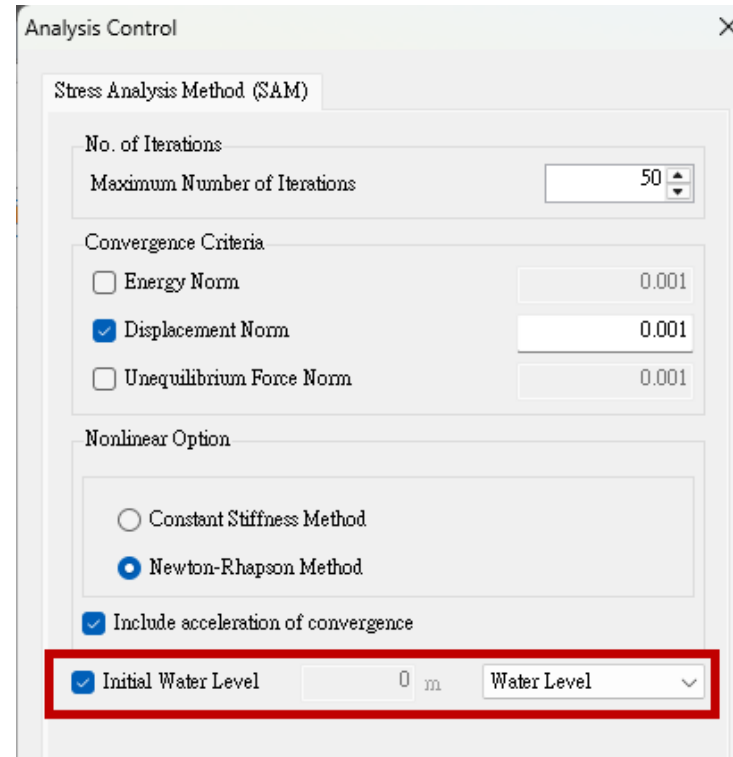
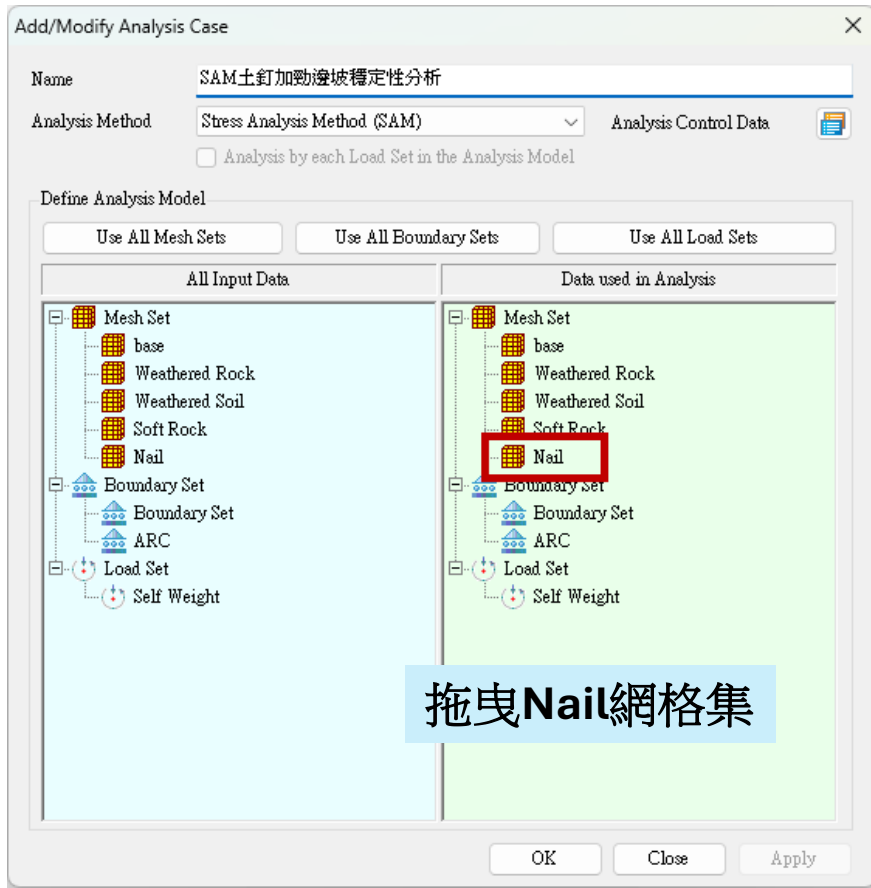
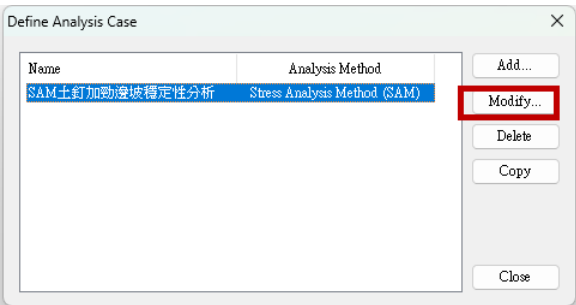
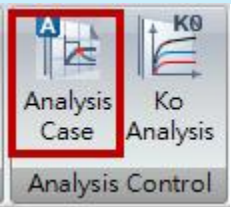

計算

SoilWorks - Soilworks_標準教學系列2_邊坡模組_2_SAM土釘加勁邊坡穩定分析_考種土釘 (Slope Module)

Geometry | Limit Equilibrium Method | Model | Loads | Boundaries | Analysis | Design | Results | Tools | Window

Partial Factor | Construction Stage | Stage Models | Simulate Construction Stages | Analysis Design Case Options | Analysis and Report | Analysis Report | Run

base | Surface

Works

- Initial Variables
- View Point
- Layer Set
 - base (Surfaces[0], Curves[0], Points[0])
 - 0 (Surfaces[0], Curves[22], Points[0])
 - 土釘圖層 (Surfaces[0], Curves[5], Points[0])
 - Smart Surface 1 (Surfaces[1], Curves[0], Points[0])
 - Smart Surface 2 (Surfaces[1], Curves[0], Points[0])
 - Smart Surface 3 (Surfaces[1], Curves[0], Points[0])
- Mesh (Elements[7229], Nodes[15083])
 - Seed Data
 - Mesh Set [5]
 - base (Elements[0], Nodes[0])
 - Weathered Rock (Elements[1454], Nodes[3107])
 - Weathered Soil (Elements[1796], Nodes[3799])
 - Soft Rock (Elements[3974], Nodes[8167])
 - Nail (Elements[5], Nodes[10])
- Property
 - Ground Material Property
 - 1 : Weathered Soil [Mohr-Coulomb]
 - 2 : Weathered Rock [Mohr-Coulomb]
 - 3 : Soft Rock [Mohr-Coulomb]
 - Structural Property
- Functions
- Loads
- Boundaries
 - Partial Factor
 - Construction Stage
 - Analysis Case

Analysis Manager

<input checked="" type="checkbox"/>	Name	Analysis Type
<input checked="" type="checkbox"/>	SAM 土釘加勁邊坡穩定性分析	Stress Analysis Method (SAM)

執行求解

Perform Analysis | Cancel Analysis | Close

Message

```
Perform Analysis Case data (Number=1) has been modified.
Perform Analysis Case data (Number=1) has been modified.
Command : ANALYSISCASE
Command : RUNANALYSIS
Command : RUNANALYSIS
```

Works | Results | Design and Report

Ready | 0% | X: 58.3206 m | Z: 35.1719 m | GRID | OSNAP | ORTHO | kN | m



SAM分析結果

(SAM土釘加勁邊坡穩定性分析)

輸出結果

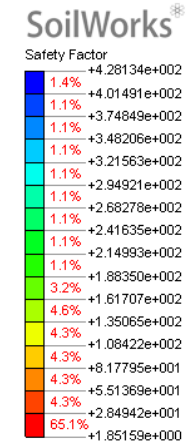
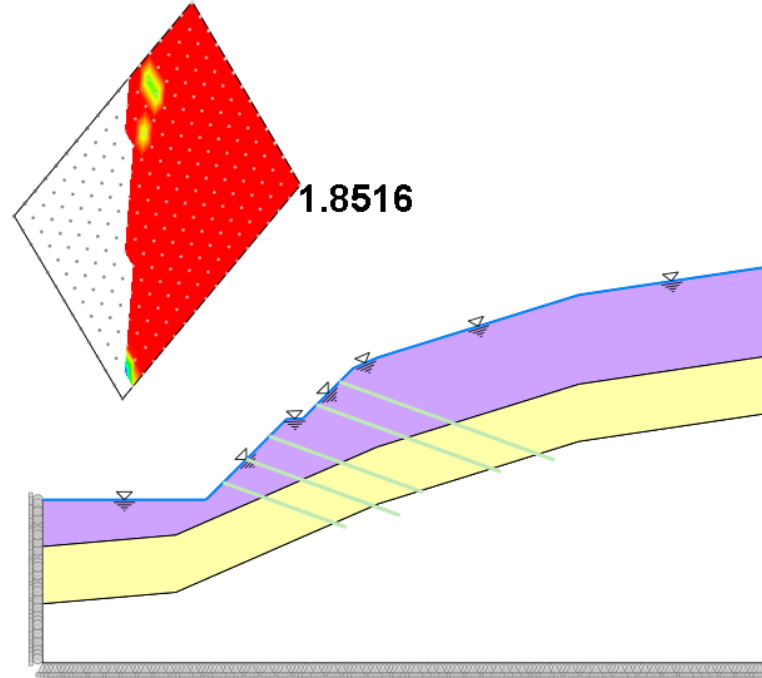
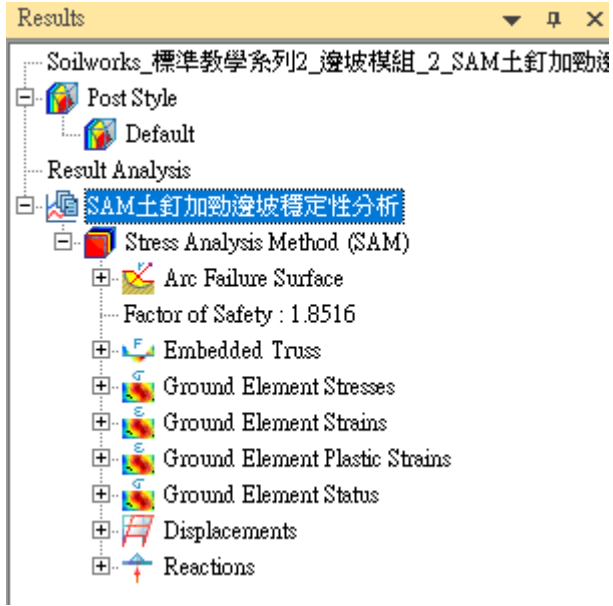

程式會自動輸出安全係數

檔案

SAM土釘加勁邊坡穩定分析_考慮土釘

